

---

European Organisation for Technical Approvals  
Europäische Organisation für Technische Zulassungen  
Organisation Européenne pour l'Agrément Technique

---

Established pursuant to Annex II of the Council Directive 89/106 of 21 December 1988 on the approximation of laws, regulations and administrative provisions of Member States relating to construction products (Construction Products Directive)

## ETAG 026

### GUIDELINE FOR EUROPEAN TECHNICAL APPROVAL

of

## Fire Stopping and Fire Sealing Products

### Part 3 Linear Joint and Gap Seals

Progress file

August 2011

This Guideline for European Technical Approval is established and published in accordance with Article 11 of the Construction Products Directive as a basis for the preparation and issue of European technical approvals in accordance with Article 9.1 of the Construction Products Directive.

European Technical Approvals are issued by approval bodies authorised and notified in accordance with Article 10 of the Construction Products Directive. These bodies are organized in EOTA.

The European Technical Approval, according to the Construction Products Directive, is a favourable technical assessment of the fitness for use of a construction product and the technical specification of the assessed product, serving as basis for the CE marking of this product when and where a harmonised standard according to the Directive is not or not yet available.

Due to technical innovation and the progress of the state of the art, guidelines for technical approval might not reflect the latest developments and experiences gained in approval procedures. The reader of this Guideline is therefore advised to check with an EOTA member whether there are further provisions which have to be taken into account in the use of the Guideline.

Copy right: EOTA

Note: The copy right refers to the English reference version established by EOTA. For publications in accordance with Article 11.3 of the Construction Products Directive the national laws, regulations and administrative provisions of the Member State concerned are applicable.

<b>Table of contents</b>		<b>Page</b>
<b>1</b>	<b>Scope of the ETAG</b> .....	<b>4</b>
1.1	Definition of the construction product .....	4
1.2	Intended use of the construction product .....	6
1.3	Assumed working life of the construction product .....	7
1.4	Terminology .....	7
1.5	Procedure in the case of a significant deviation from the ETAG .....	8
<b>2</b>	<b>Assessment of fitness for use</b> .....	<b>9</b>
2.1	Meaning of "fitness for use" .....	9
2.2	Elements of the assessment of fitness for use .....	9
2.3	Relationship of requirements to the product characteristics and methods of verification and assessment .....	9
2.4	Product characteristics relevant for the fitness for use .....	10
<b>3</b>	<b>Evaluation and attestation of conformity and CE marking</b> .....	<b>23</b>
3.1	System of attestation of conformity .....	23
3.2	Tasks and responsibilities for the manufacturer and notified bodies .....	23
3.3	CE marking and accompanying information .....	26
<b>4</b>	<b>Assumptions under which the fitness for the intended use is assessed</b> .....	<b>27</b>
4.1	Manufacture of the product .....	27
4.2	Packaging, transport, storage of the product .....	26
4.3	Installation of the product in the works .....	27
4.4	Use, maintenance, repair .....	27
4.5	Auxiliary components .....	27
<b>5</b>	<b>Identification of the construction product</b> .....	<b>27</b>
5.1	Means of identification .....	27
5.2	Product characteristics relevant for identification checking .....	30
<b>6</b>	<b>Format of Etas issued on the basis of the ETAG</b> .....	<b>30</b>
<b>7</b>	<b>Reference documents</b> .....	<b>30</b>
7.1	EC Documents .....	30
7.2	Product Specifications .....	30
7.3	Test methods and classification standards .....	31
7.4	Others .....	32
<b>Annex A</b>	<b>Mounting and Fixing Procedures for Reaction to Fire Tests</b> .....	<b>33</b>
A.1	Tests according to EN 13823 (SBI) .....	33
A.2	Tests according to EN ISO 11925-2 (small burner test) .....	35
<b>ANNEX B</b>	<b>Tests for the Aspects of Serviceability and Identification</b> .....	<b>36</b>
B.1	FTIR (Fourier transform Infra-Red Spectroscopy) .....	36
B.2	Thermo-analytical methods .....	36
B.3	Content of non-volatile components .....	36
B.4	Loss of mass on heating .....	36
B.5	Mechanical properties .....	36
B.6	Density .....	37
B.7	Viscosity .....	37
B.8	Behaviour of mineral wool at high temperature .....	37
B.9	Curing behaviour .....	39
B.10	Dimensions .....	39
B.11	Dimensional stability .....	39
B.12	Visual examination .....	43
B.13	Methods for determination of movement capability (mc) .....	43
B.14	Compression set .....	44
B.15	Determination of a "corrosion" rate .....	44
<b>Annex C</b>	<b>Water Permeability Tests</b> .....	<b>45</b>
C.1	Test to simulate external use (rain) .....	45
C.2	Test to simulate internal use (water pressure test) .....	45
<b>Annex D</b>	<b>Flow Diagram for the Selection of the Relevant Conditions of the Resistance to Fire Test</b> ..	<b>46</b>

<b>Annex E</b>	<b>Details for Resistance to Fire Test Conditions for Movement Joint Seals</b>	<b>47</b>
E.1	Case a) according to 2.4.2.1.3: Nominal width + elongation	47
E.2	Case b) according to 2.4.2.1.3: Nominal width + shear	48
E.3	Combination of elongation and shear	49
<b>Annex F</b>	<b>Rules for determining the field of application</b>	<b>51</b>
<b>Addendum:</b>	<b>Model for ETAs issued on the basis of ETAG 026 part 3</b>	<b>53</b>

## Foreword

This ETA-Guideline has been drawn up by the EOTA Task Group "Linear Joint and Gap Seals" of the WG 11.01/04 "Fire Stopping and Fire Sealing Products".

In this Part requirements and test information additional to Part 1 – "General" and applicable only for sealing linear joints and gaps are given, taking into account the specific family of products referred to in the scope.

This ETA-Guideline - Part 3 "Linear joint and gap seals" shall be used in conjunction with the ETA-Guideline "Fire Stopping and Fire Sealing Products, Part 1 – "General". The same numbering of paragraphs as in Part 1 – "General" is used. If a paragraph is not mentioned, then the text in Part 1 – "General" applies without modification.

If the product is a reactive product, or a kit containing a reactive product, this ETA-Guideline – Part 3 "Linear joints and gap seals" shall also be used in conjunction with the ETA-Technical Report "Characterisation, Aspects of Durability and Factory Production Control for Reactive Materials, Components and Products".





## 1 SCOPE OF THE ETAG

### 1.1 Definition of the construction product

This ETA-Guideline N°026, Part 3 "Linear Joint and Gap Seals" deals with linear joint and gap seals and shall be used in conjunction with Part 1 – "General" of this ETAG. This part of the Guideline includes perimeter joints for curtain wall facades. Glazing seals and door seals are not covered by this ETAG.

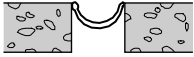
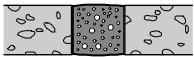
The seals are intended to prevent or restrict the passage of fire (and/or hot smoke) between elements or components or to maintain the integrity and insulation performance of one or more fire separating elements at linear discontinuities for a specified duration and are designed either to accommodate movement (hereafter designated as "movement joints") or not to accommodate movement (hereafter designated as "non-movement joints").

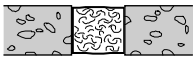
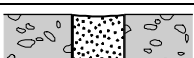
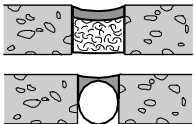
The following is a list of products (non-exhaustive) that may be used individually or in combination with other components to form a linear joint seal:

Product	Type of fixing <sup>1</sup>	Illustration of the final sealing system (side elevation)
Fabrics	AF, MF	
Foams (foamed in-situ type materials, e.g. PUR, silicone, dispensed from a cartridge or can)	SA	
Membrane-forming coatings (normally used together with a backing material)	SA	
Mineral wool (faced/coated or non-faced/coated)	AF*, FF*, MF***	
Mortar (cement or gypsum based) <sup>2</sup>	SA, (MF)	
Sealants (e.g. acrylics, silicone, oil-based products (mastic), foamed in-situ; normally used together with a backing material)	SA	
Strips, compressible (including composite)	AF**, FF**, MF***	
Strips, elastomeric	AF, MF	

\* e.g. mineral wool covered by fabric, mineral wool strips, edged with Al-foil

\*\* e.g. foam strips (laminated, impregnated or composite)

\*\*\* e.g. by means of hangers or trays

<sup>1</sup> AF = adhesion fixed, FF = friction fixed, MF = mechanically fixed, SA = self-adherent

<sup>2</sup> This document covers products that require only the addition of water

Linear joint or gap seals often consist of several components (e.g. sealant + mineral wool). The assessment shall cover the whole assembly. Where the seal is not sold as a kit, the components not covered by the ETA will be specified in the ETA. It is the responsibility of the installer to obtain these components for incorporation into the assembled system. However, any component not included in a kit and hence not covered by the ETA, is not covered by the Attestation of Conformity (AoC) provisions of the ETA. This ETAG is not to be used to produce an ETA for components that do not contribute to the fire resistance of the assembled system, e.g. PE foam backer rods.

For the purpose of this document,

- the term "product" is used regardless of whether the linear joint seal or gap seal is offered as a kit or an individual component forming part of an assembled system in the works.
- the terms "linear joint seal" and "joint" are used regardless of whether the seal is designed to be used as a joint or a gap seal.

It is important to consider linear joint seals in relation to the orientation of the joint/gap in which they are used (see figure 1.1), as this can have a bearing on their adequacy.

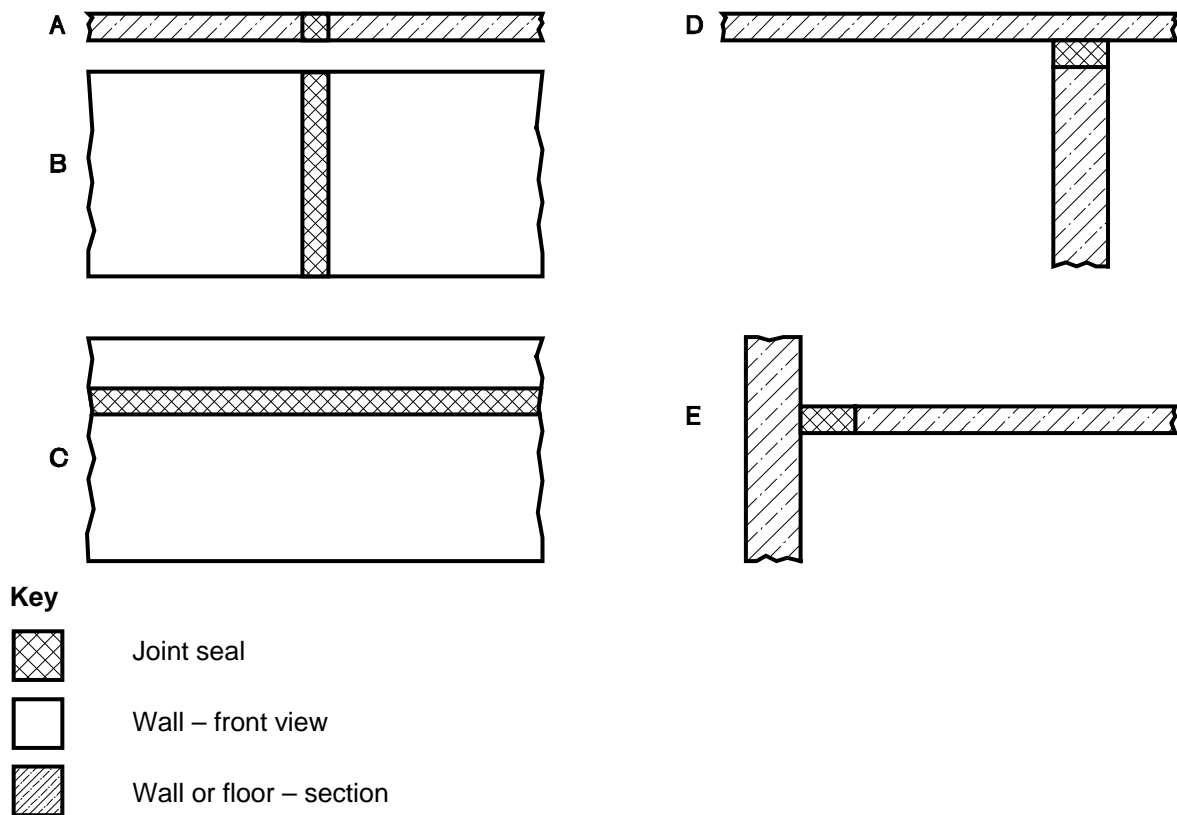

- A Joint seal in a floor
- B Vertical joint seal in a wall
- C Horizontal joint seal in a wall
- D Horizontal wall joint abutting a floor, ceiling or roof
- E Horizontal floor joint abutting a wall

**Figure 1.1 – Possible orientations of linear joint seals**

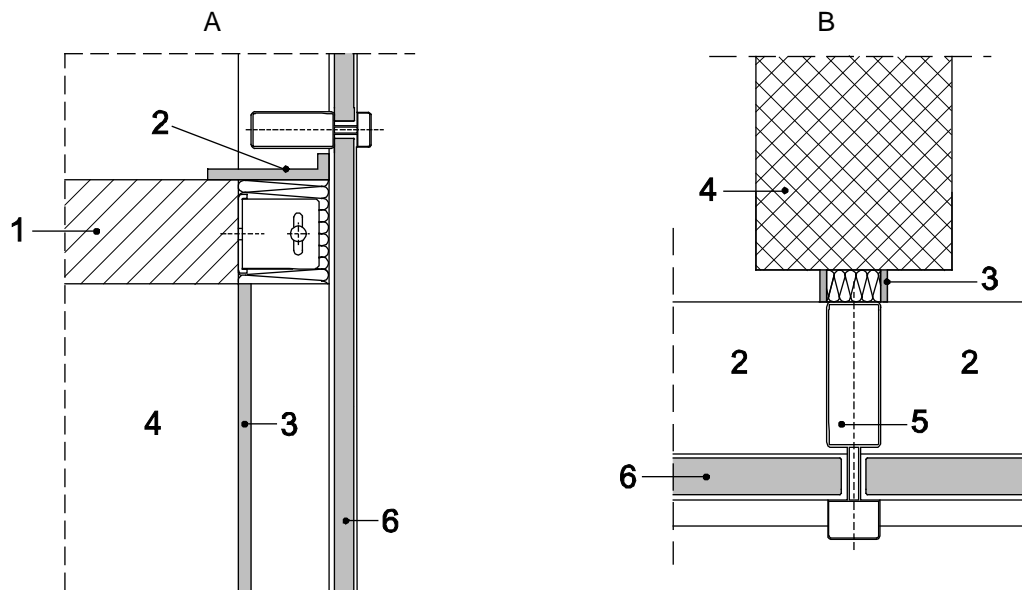

### Key

- A Vertical section
- B Horizontal section
- 1 Supporting floor
- 2 Horizontal linear joint seal / perimeter seal
- 3 Vertical joint seal
- 4 Wall abutting the curtain walling
- 5 Mullion
- 6 Spandrel area (upstand / downstand / combination)

**Figure 1.2 – Linear joint seals abutting curtain walling**

## 1.2 Intended use of the construction product

The linear joint and gap seals may be used in various environmental conditions, described by the following use categories, related to the type of environmental conditions. These are based on the general principles specified in Part 1 – "General". The use categories are:

- Type X: intended for use in conditions exposed to weathering.
- Type Y<sub>1</sub>: intended for use at temperatures below 0°C with exposure to UV but no exposure to rain.
- Type Y<sub>2</sub>: intended for use at temperatures below 0°C, but with no exposure to rain or UV.
- Type Z<sub>1</sub>: intended for use in internal conditions with humidity equal to or higher than 85 % RH, excluding temperatures below 0°C<sup>3</sup>.
- Type Z<sub>2</sub>: intended for uses in internal conditions with humidity lower than 85 % RH excluding temperatures below 0°C.

Requirements relevant for the establishment of the use categories are presented in clause 2.4.13.

**Note 1** Products that meet requirements for type X, meet the requirements for all other types. Products that meet requirements for types Y<sub>1</sub> also meet the requirements for type Y<sub>2</sub>, Z<sub>1</sub> and Z<sub>2</sub>. Products that meet requirements for types Y<sub>2</sub> also meet the requirements for type Z<sub>1</sub> and Z<sub>2</sub>. Products that meet the requirements for type Z<sub>1</sub>, also meet the requirements for type Z<sub>2</sub>.

It should be recognised, however, that although it is acceptable for a linear joint seal to be intended for indoor applications only, the construction process may result in it being subjected to more exposed conditions for a period before the building envelope is closed. In this case the possibilities are:

1. Special provisions to temporarily protect the exposed linear joint seals according to the instructions

<sup>3</sup> These uses apply for internal humidity class 5 in accordance with EN ISO 13788.

of the manufacturer which are referenced in the ETA.

2. Evaluation of the linear joint seal as if it were to be used for exposed applications (type X)  
or
3. For established products only, evaluation of the product for type Y or type Z applications (as appropriate) and acceptance by the Approval Body of the possibility of short term exposure based on long term experience and evidence of such exposure, provided that
  - this long term experience is well documented, and
  - the product subject to the approval procedure is the same as the product for which the performance is established by this long term experience.

This part of ETAG 026 does not define specific test methods for the resistance to conditions other than those listed above (see clause 2.4.13.1.1.1). So it may be necessary to assess the product's resistance to specific environmental conditions case by case. The Approval Body shall obtain suitable evidence for the assessment and present details in the ETA.

### **1.3 Assumed working life of the construction product**

The provisions, verification and assessment methods included or referred to in this ETAG have been written based upon the assumed working life of the Fire Stopping and/or Fire Sealing Product for the intended use of 25 years when installed in the works, provided that the Fire Stopping and/or Fire Sealing Product is subject to appropriate use and maintenance (see clause 4.4). However, if the product is a reactive material or includes a reactive material, the working life is assumed to be 10 years or 25 years depending on what evidence is available. These provisions are based upon the current state of the art and the available knowledge and experience.

Additional assumptions made are given in Part 1 – "General".

"Assumed working life" means that, when an assessment following the ETAG provisions is made, and when this working life has elapsed, the real working life may be, in normal use conditions, considerably longer without major degradation affecting the Essential Requirements.<sup>4</sup>

The indications given as to the working life of the construction product cannot be interpreted as a guarantee given by the product manufacturer or his representative or the Approval Body issuing the ETA, but are regarded only as a means for choosing the appropriate products in relation to the expected economically reasonable working life of the works (see 5.2.2 of the Interpretative Documents).

## **1.4 Terminology**

### **1.4.1 Common terms relating to the Construction Products Directive**

For the meaning of these terms see EOTA document "Common terms used in Guidelines for European technical approval" published on the EOTA website.

### **1.4.2 Specific terms used in this part of the ETAG**

For this Part of the ETAG the terminology and abbreviations as given in Part 1 – "General" of this ETAG apply, together with the following:

#### **1.4.2.1 Linear joint**

Linear void having a length to width ratio of at least 10:1 within one or between two or more juxtaposed construction elements

#### **1.4.2.2 Linear joint seal**

System designed to maintain the fire separating function, and if relevant, to accommodate a specified degree of movement within the linear joint

---

<sup>4</sup> The real working life of a product incorporated in a specific works depends on the environmental conditions to which that works is subject and the particular conditions of the design, execution, use and maintenance of that works. Therefore, the possibility cannot be excluded that there are cases where the real working life of the product may also be shorter than the assumed working life.

### 1.4.2.3 Movement joint

Is a linear discontinuity between elements of construction or within the elements themselves, in order to accommodate relative movement of these elements. Examples of such relative movements may be accommodation of load deflection, thermal movement or settlement/subsidence or the joint may have a seismic function.

**Note 2:** A movement capability of  $\geq 7,5\%$ <sup>5</sup> of the seal is considered to be necessary for a movement joint.

### 1.4.2.4 Non-movement joint

Non-movement joints (or gaps) do not allow for relative movement between elements.

### 1.4.2.5 Movement capability

Maximum amount of movement the joint seal is able to tolerate expressed as a percentage of the nominal width.

**Note 3** Products with a movement capability of  $\geq 7,5\%$  are considered to be suitable for movement joints.

### 1.4.2.6 Strip

A pre-fabricated seal normally inserted into the gap and held in place by friction or by means of an adhesive.

### 1.4.2.7 Cover strip

A product normally made of plastic or metal designed to protect the joint seal from contamination and damage and/or for aesthetic purposes.

### 1.4.2.8 Joint depth

The overall distance between the exposed and unexposed faces across the thickness of the separating element – see figure 1.3.

### 1.4.2.9 Seal depth

The shortest distance between the exposed and unexposed surfaces of the seal – see figure 1.3.

### 1.4.2.10 Joint width

The distance between two adjacent faces – see figure 1.3.

### 1.4.2.11 Overall seal width

The overall width of the seal includes any fixings or overlap. This may differ from the joint width.

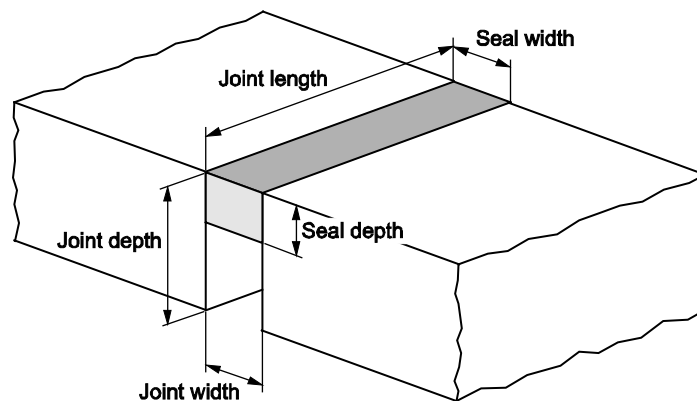

Figure 1.3 – Definition of seal depth, joint depth and joint width

## 1.5 Procedure in the case of a significant deviation from the ETAG

See Part 1 – "General"

<sup>5</sup> 7,5% is the lowest class allowed for movement capability in ISO 11600



## 2 ASSESSMENT OF FITNESS FOR USE

### 2.1 Meaning of "fitness for use"

See Part 1 – "General"

### 2.2 Elements of the assessment of fitness for use

See Part 1 – "General"

### 2.3 Relationship of requirements to the product characteristics and methods of verification and assessment

The product characteristics, methods of verification and assessment criteria which are relevant for the fitness of Fire Stopping and Fire Sealing Products for the intended use referred to in clause 1.2 are given in Table 1 of Part 1 – "General" and apply except where modified or specified below.

**Table 1 - Product characteristics and methods of verification and assessment**

N°	Product characteristic	Option "No Performance Determined (NPD)"	Method of verification and assessment	Expression of product performance
1	2	3	4	5
Essential Requirement 1: Mechanical resistance and stability				
	None			
Essential Requirement 2: Safety in case of fire				
1	Reaction to fire <sup>6</sup>	Permitted: class F according to EN 13501-1	2.4.1	Classes A1-F according to EN 13501-1
2	Resistance to fire 4.2.3 Limitation of generation and spread of fire and smoke within construction works	Not permitted	2.4.2	Classification according to EN 13501-2
Essential Requirement 3: Hygiene, health and environment				
3	Air permeability (material property)	Permitted	2.4.3	Declared value
4	Water permeability (material property)	Permitted	2.4.4	Pass / fail
5	Release of dangerous substances	Permitted	2.4.5	Indication of dangerous substances or "No dangerous substances" <sup>7</sup>

<sup>6</sup> In this text "classified according to EN 13501-1" means classification according to EN 13501-1, or classification A1 according to Decision 96/603/EEC as amended or according to a relevant CWFT Decision as stated in the FOREWORD of EN 13501-1.

<sup>7</sup> EU data base see: <http://ec.europa.eu/enterprise/construction/cpd-ds/index.cfm>

Essential Requirement 4: Safety in use				
6	Mechanical resistance and stability	Permitted	2.4.6	See N°7 of this table
7	Resistance to impact/movement	Permitted	2.4.7	Impact energy value
8	Adhesion *	Permitted****	2.4.8	See N° 7 of this table
Essential Requirement 5: Protection against noise				
9	Airborne sound insulation	Permitted	2.4.9	Single number rating
10	Impact sound insulation	Permitted	2.4.10	Single number rating
Essential Requirement 6: Energy economy and heat retention				
11	Thermal properties	Permitted	2.4.11	Declared value
12	Water vapour permeability **	Permitted	2.4.12	Declared value
General aspects relating to fitness for use ***				
13	Durability and serviceability	Not permitted	2.4.13	Use category regarding environmental conditions
*	This characteristic is placed under ER 4 for convenience, but also relates to other ER as well, particularly ER 2			
**	This characteristic also relates to ER 3			
***	Aspects of durability and economy of the works (see CPD Annex 1, sentence 1 and 2) which are not dealt with under Essential Requirements 1 to 6. Such aspects are also referred to as "serviceability".			
****	not permitted for AF and SA type seal (see footnote 1)			

## 2.4 Product characteristics relevant for the fitness for use

### 2.4.1 Reaction to fire

#### 2.4.1.1 Method of verification

##### **Case 1: Normal case**

See Part 1 – "General" for general information.

Where the test regime for a certain class requires a test according to EN 13823 (SBI) the mounting and fixing procedure described in Annex A.1 shall be used.

Further details for tests according to EN ISO 11925-2 are given in Annex A.2.

##### **Case 2: Products satisfying the requirements for the fire reaction class A1, without the need for testing**

See Part 1 – "General"

##### **Case 3: Products classified without the need for further testing (CWFT)**

See Part 1 – "General"

#### 2.4.1.2 Method of assessing and judging

The product shall be classified according to EN 13501-1.

## **2.4.2 Resistance to fire**

### **2.4.2.1 Method of verification**

#### **2.4.2.1.1 General**

The part of the works or assembled system in which the Fire Stopping and/or Fire Sealing Product is intended to be incorporated, installed or applied shall be tested, using the test method relevant for the corresponding fire resistance class, in order to be classified according to EN 13501-2.

Tests shall be conducted in accordance with EN 1364-4 in the case of perimeter seals for curtain walling, in accordance with EN 1364-3 in the case of vertical linear joints abutting curtain walling or EN 1366-4 for all other linear joint seals together with the following provisions of this Guideline to allow a classification according to EN 13501-2.

An informative flow diagram for the selection of the relevant conditions in the resistance to fire test is given in Annex D.

The test configuration shall be determined based on the desired field of application, taking account of the standard configurations and the rules given in EN 1366-4 or EN 1364-4 or EN 1364-3 and this ETAG. For tests in accordance with EN 1366-4, test orientations A, B and C, as shown in Figure 1.1 of this ETAG are normally used.

#### **2.4.2.1.2 Test configuration regarding seal width and depth**

##### **2.4.2.1.2.1 Fabrics**

For seals made of either various thicknesses or several layers of one thickness of fabric, test with the number of layers in the seal but with the minimum material thickness and maximum nominal joint width for the intended Fire resistance performance.

##### **2.4.2.1.2.2 Foams – foamed in-situ**

To achieve a field of application that covers the available joint width / seal depth combinations for the required Fire resistance performance, the following rules shall be applied for defining the necessary tests:

Test results for a particular seal depth and nominal joint width cover narrower nominal joint widths or greater seal depths.

**Note 4** Normally the thickness of the supporting construction will limit the seal depth. For certain seal types the seal depth may be limited mechanically e.g. by its own mass.

Where only one seal depth is specified for a particular fire resistance period for all joint widths a single test at the maximum joint width is sufficient. If the seal depth varies with the joint width a test shall be conducted at the maximum nominal joint width for each related seal depth specified by the manufacturer.

It is not normally permissible to derive intermediate points between those tested. However, where there is sufficient data to allow sensible analysis, this approach may be considered.

##### **2.4.2.1.2.3 Membrane forming coatings**

The test shall be carried out using the minimum thickness (minimum of tolerance band for the nominal thickness) of the membrane, minimum depth of mineral wool (or other backfilling material), maximum width and minimum overlap at the substrate for the intended fire resistance performance. This fire resistance performance will apply for all thicknesses within the tolerance band for the membrane, thicker mineral wool (or other backfilling material), smaller width and higher overlap. Substrates are covered for which the adhesion is shown to be equal to or better than that tested. When a primer is part of the system, it shall be included in the test. Each primer shall be tested separately.

##### **2.4.2.1.2.4 Mineral wool (faced/coated or non-faced/coated)**

See the rules given in clause 2.4.2.1.2.2 subject to the following:

The compression characteristics through a slab of mineral wool will vary depending on which axis the compression is applied. As a result, the field of application for a mineral wool joint seal will depend on its orientation within the joint. Similarly, this can also be dependent on the fibre orientation introduced during production and the way it was cut from its original slab.

Figure 2.4.1 depicts a slab of mineral wool, with the three potential directions of applying the required compression to produce an effective fire-stopping seal:

- A⇔A – through the slab thickness, as produced
- B⇔B – along the slab length
- C⇔C – across the slab width

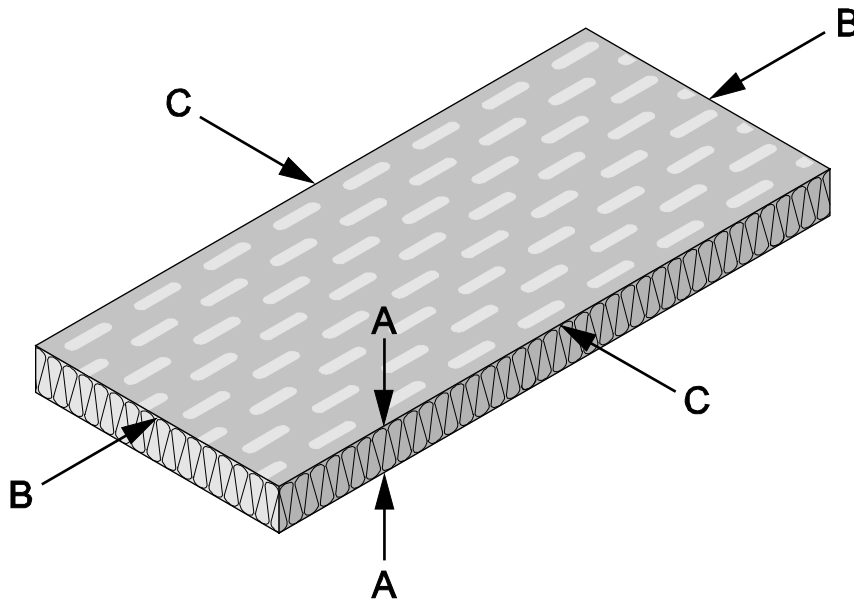

**Figure 2.4.1 – Mineral wool – Compression directions**

When a seal with a constant depth but variable joint width is considered, it shall be subjected to a fire resistance test at the maximum nominal joint width. The degree of initial compression (%) exerted on the seal by the joint width shall be recorded.

For a seal compressed in the A⇔A direction, such a test covers a smaller joint width, provided the degree of compression (%) exerted on the seal is equal to or greater than that used in the test.

For a seal compressed in the B⇔B or C⇔C directions, such a test covers a smaller joint width and/or higher compression, provided that the compression applied is not sufficient to induce a mechanical failure of the seal e.g. a de-lamination fracture of the mineral wool or coating.

**2.4.2.1.2.5 Mortar/plaster**

Test at maximum nominal joint width and the corresponding minimum seal depth.

Test results for a particular seal depth and nominal joint width cover narrower nominal joint widths or greater seal depths.

**2.4.2.1.2.6 Sealants**

These products are normally used in combination with a backing material. The seal depth is the sum of the thicknesses of the sealant and the backing material.

To achieve a field of application that covers the available joint width / seal depth combinations for the required fire resistance performance, the following rules shall be applied for defining the necessary tests:

Test results for a particular nominal joint width cover narrower nominal joint widths provided the depth of the sealant and the backing material are equal to or greater than those tested.

**Note 5** Normally the thickness of the supporting construction will limit the seal depth. For sealants the thickness may be limited by mechanical stability.

Where only one seal depth, with a specified combination of sealant to backing material thickness, is specified for all joint widths a single test may be sufficient. If the thickness of the sealant or the backing material varies with the joint width a test shall be conducted at the maximum nominal joint width for each related seal depth specified by the manufacturer.

It is not normally permissible to derive intermediate points between those tested. However, where there is sufficient data to allow sensible analysis, this approach may be considered.

**2.4.2.1.2.7 Strips, compressible (including composite):**

The same rules and approach apply as for foams – foamed in-situ.

#### **2.4.2.1.2.8 Strips, elastomeric**

Test at the minimum thickness (minimum of tolerance band for the nominal thickness) of the strip, maximum joint width and minimum overlap at the substrate. Extrapolation is permissible to thicknesses within the tolerance band for the strip, smaller widths and higher overlap. Substrates are covered for which the adhesion is shown to be equal to or better than that tested. When a primer is part of the system it shall be included in the test. Each primer shall be tested separately.

#### **2.4.2.1.3 Test conditions regarding movement**

##### **2.4.2.1.3.1 Tests according to EN 1366-4**

Where a movement capability of  $\geq 7,5\%$  is claimed the seals shall be tested with a superimposed displacement.

The test conditions are:

a) Maximum width (nominal joint width + lateral elongation corresponding to 100% of the movement capability, see figure E.1 in Annex E)

or

b) Maximum width (nominal joint width + shear corresponding to 100% of the movement capability, see figure E.2 in Annex E)

For further details see Annex E.

The displacement may be imposed prior to the test or during the test in accordance with EN 1366-4. The displacement shall amount to 100% of the movement capability determined according to clause 2.4.13.2, claimed by the manufacturer. For details see Annex E.

If required by the manufacturer, displacement conditions, other than the standard conditions described in EN 1366-4, may be used additionally.

##### **2.4.2.1.3.2 Tests of perimeter seals according to EN 1364-4**

A test according to clause 2.4.13.2.2 shall be performed with the fire test specimen before the fire test. The fire test is commenced at the nominal joint width.

##### **2.4.2.1.3.3 Tests of vertical linear joint seals abutting curtain walling according to EN 1364-3**

The movement is assumed to be generated by bending of the mullions comparable as in practice as this is a full scale test.

##### **2.4.2.1.4 Standard flexible wall constructions for tests according to EN 1366-4 and EN 1364-3**

The provisions given in prEN 1366-3:2006, concerning the construction and field of application rules, may be applied for linear joints.

#### **2.4.2.2 Method of assessing and judging**

The part of the works or assembled system in which the Fire Stopping and/or Fire Sealing Product is intended to be incorporated, installed or applied shall be classified according to EN 13501-2.

##### **Field of application**

Depending of the type of linear joint seal tested the rules of EN 1366-4, EN 1364-3 or EN 1364-4 shall be applied.

Further principles are given in Annex F.

The tables in Annex F show the possible variations, the expected effect and a comment on that effect. The effects are annotated as + (a positive effect expected), - (a negative effect expected) or = (no significant effect expected). Where no annotation of effect is given the effect is currently not known.

At present the rules in Annex F only consider the effect of one variation at a time, all other parameters remaining unchanged.

If more than one variation is to be incorporated, the overall effect shall be considered.

The rules are considered applicable to joint assemblies tested either with or without induced movement.

#### **2.4.3 Air permeability**

##### **2.4.3.1 Method of verification**

The leakage rate is the sum of the leakage between the seal and the surrounding structure and the permeability of the seal itself. The former is proportional to the length of the seal and the latter is proportional to the exposed area of the seal for a given depth of seal. In many cases one of these mechanisms predominates and it is only necessary to consider this mechanism. In others it may not be clear which predominates and both mechanisms may have to be evaluated. A comparison of the results for

a 1 m length of seal will reveal whether one mechanism dominates or whether both mechanisms need to be taken into account to obtain the overall leakage rate.

To determine air permeability <sup>8</sup> the principles of the test method described in EN 1026:2000 shall be used, noting the following with reference to this standard:

Clause 6: A nominal length of the linear joint seal of 1 m together with the intended supporting construction (to be agreed between the Approval Body and the ETA applicant) is considered to be sufficient. Regarding selection of the appropriate width all effects that could influence the test result shall be considered (e.g. degree of compression). Linear joint seals shall be tested from both sides separately unless symmetrical in construction. A splice/butt joint shall be included in the test specimen where relevant. Linear joint seals intended to be used for movement joints shall be tested using the displacement conditions described in clause 2.4.2.1.3.

When seal edge leakage is intended to be determined for permeable materials coat the seal surface with an impermeable coating, e.g. varnish, epoxy resin, self-adhesive film or impermeable sealant.

When seal material permeability is intended to be determined reduce edge leakage to zero using an impermeable sealant or adhesive to bond the seal to the surrounding construction.

#### **2.4.3.2 Method of assessing and judging**

Seal edge leakage

The test result shall be presented as leakage rate per unit length of the seal, with the unit being  $m^3h^{-1}m^{-1}$  since leakage is proportional to length of seal. For symmetrical seals there are two leakage edges but results shall be expressed in terms of linear metres of seal.

Seal material permeability

The test result shall be presented as leakage rate per unit area of the seal, with the unit being  $m^3h^{-1}m^{-2}$  (in deviation from clause 8 of EN 1026:2000) for a defined pressure differential and seal depth since leakage is proportional to the exposed surface area.

The leakage rate of seals of greater depth than that tested can be assumed to be equal or less.

#### **2.4.4 Water permeability**

##### **2.4.4.1 Method of verification**

For external seals: See test method described in Annex C.1 (normally relevant only to walls)

For internal seals: See test method described in Annex C.2 (normally relevant only to floors).

##### **2.4.4.2 Method of assessing and judging**

For external seals: See Annex C.1.

For internal seals: See Annex C.2.6.

#### **2.4.5 Release of dangerous substances**

##### **2.4.5.1 Method of verification**

See Part 1 – "General"

##### **2.4.5.2 Method of assessing and judging**

See Part 1 – "General"

#### **2.4.6 Mechanical resistance and stability**

##### **2.4.6.1 Method of verification**

See 2.4.7.1

**Note 6** It is assumed that the impact test covers both static and dynamic loads.

##### **2.4.6.2 Method of assessing and judging**

See 2.4.7.2

---

<sup>8</sup> While the test described in EN 1026:2000 is similar in principle to that described in EN 1634-3:2005 it is included here because the differential air pressures in EN 1634-3:2005 relate only to those occurring under fire conditions.

## **2.4.7 Resistance to impact / movement**

### **2.4.7.1 Method of verification**

#### **2.4.7.1.1 General**

Tests according to EOTA TR 001:2003 shall be used to show evidence of impact resistance/ load-bearing capacity, only where

- the seal width is in excess of 150 mm

and where either

- no precautions (precautions/protection are not covered by this ETAG) are taken to prevent a person stepping onto a horizontal linear joint seal or falling against a vertical, or sloped, linear joint seal

or

- the necessary load-bearing capacity (to prevent any injury of persons e.g. by failure of the seal) is required to be maintained,.

Where the linear joint is designed for a width in excess of 150 mm but less than 400 mm the test methods described in EOTA TR 001:2003, clause 3 apply. Where the width is in excess of 400 mm EOTA TR 001:2003, clause 2 applies, subject to the following provisions:

#### **2.4.7.1.2 Design of the specimens**

The specimens shall consist of a supporting construction with the joint seal located at the mid position. The standard material for the supporting construction is aerated concrete. Where other materials for the supporting construction are used, results are only valid for the material used in the test. The specimen shall be mounted in a steel frame (see figures 2.4.2 and 2.4.3). The thickness of the steel frame shall be minimum 5 mm. The frame shall be fixed rigidly and measures shall be taken to minimise deflection of the supporting construction at impact. Where L angles were used for the frame the impact shall be at the specimen face opposed to the steel angle.

#### **2.4.7.1.3 Size of the specimen, when the hard body impactor is used (see figure 2.4.2)**

The specimen shall have a size of 625 mm x (200 + maximum seal width applied for + 200) mm<sup>9</sup>. It is recommended to use the specimen with the seal in horizontal position to avoid impacting the supporting construction.

#### **2.4.7.1.4 Size of the specimen, when the soft body impactor is used (see figure 2.4.3)**

The specimen shall have a size of 1250 mm x (200 + maximum seal width applied for + 200) mm . It is recommended to use the specimen with the seal in vertical position to avoid impacting the supporting construction.

---

<sup>9</sup> 625 mm, 200 mm and 1250 mm are nominal values

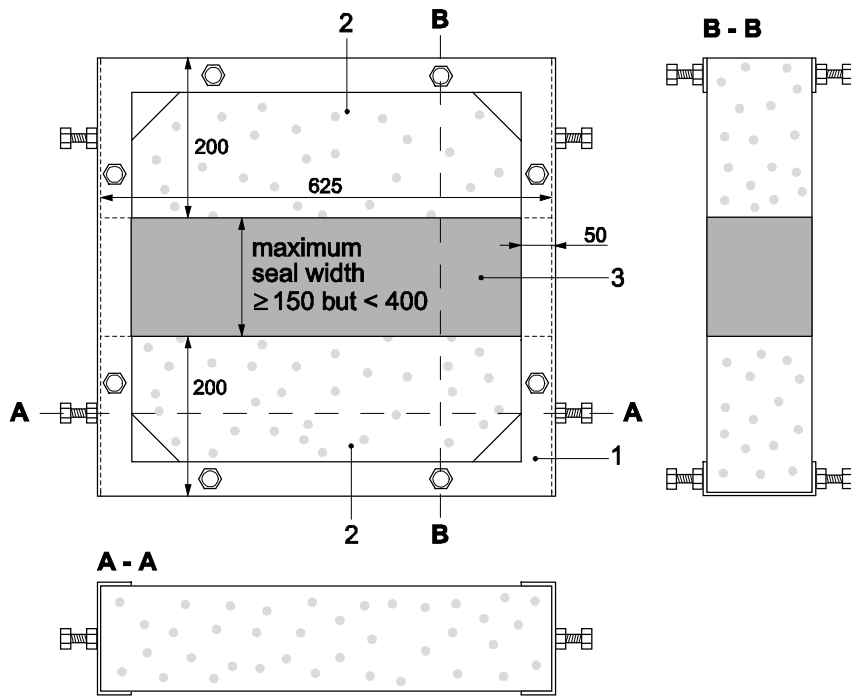

**Key**

- 1 Steel frame
- 2 Supporting construction
- 3 Joint seal

Dimensions in mm

**Figure 2.4.2 – Specimen for impact tests using the hard body impactor**



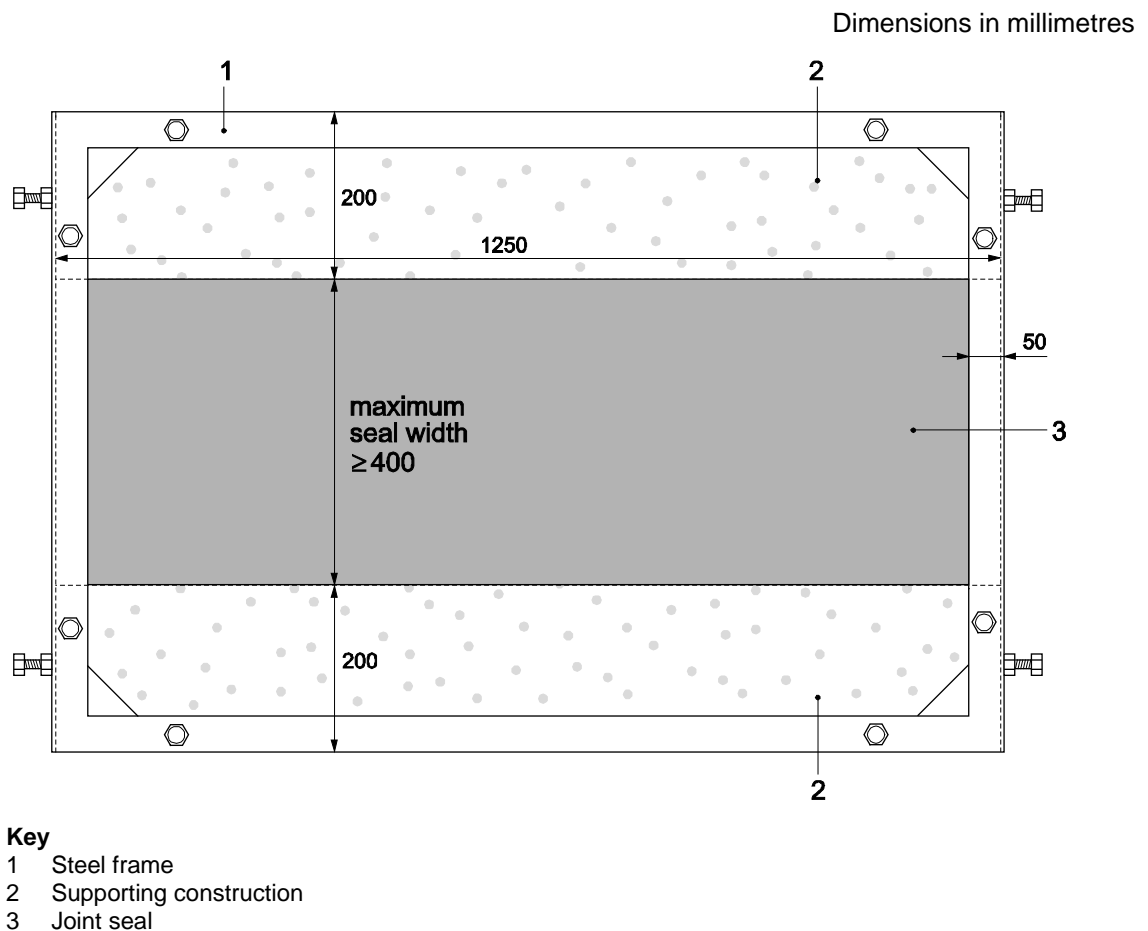

**Figure 2.4.3 – Specimen for impact tests using the soft body impactor**

#### **2.4.7.2 Method of assessing and judging**

The impact energy (see EOTA TR 001) shall be given in the ETA together with the maximum dimensions of the linear joint seal and the type of impactor used.

#### **2.4.8 Adhesion**

##### **2.4.8.1 Method of verification**

Adhesion is covered by tests carried out for the determination of movement capability (see clause 2.4.13.2.1) and, where relevant, by tests performed according to clause 2.4.7.1. When a primer is considered necessary to improve either adhesion of the product to the substrate or to enhance the cohesion of the substrate the primer shall also be used in the tests.

##### **2.4.8.2 Method of assessing and judging**

See clauses 2.4.7.2 and 2.4.13.2.2

#### **2.4.9 Airborne sound insulation**

##### **2.4.9.1 Method of verification**

See Part 1 – "General"

##### **2.4.9.2 Method of assessing and judging**

See Part 1 – "General"

#### **2.4.10 Impact sound insulation**

##### **2.4.10.1 Method of verification**

See Part 1 – "General"

##### **2.4.10.2 Method of assessing and judging**

See Part 1 – "General"

## **2.4.11 Thermal resistance**

### **2.4.11.1 Method of verification**

See Part 1 – "General"

### **2.4.11.2 Method of assessing and judging**

See Part 1 – "General"

## **2.4.12 Water vapour permeability**

### **2.4.12.1 Method of verification**

See Part 1 – "General"

### **2.4.12.2 Method of assessing and judging**

See Part 1 – "General"

## **2.4.13 Durability and Serviceability**

### **2.4.13.1 Durability**

#### **2.4.13.1.1 Method of verification**

##### **2.4.13.1.1.1 General**

There are two groups of materials/products used for linear joint seal products:

- Materials/products covered by a standard: see clauses 2.4.13.1.1.2 and 2.4.13.1.1.4.
- Materials/products not covered by a standard: see clauses 2.4.13.1.1.3 and 2.4.13.1.1.4.

The assessment of any single product may need consideration of materials of both types.

If the joint seal is intended to be used in specific environmental conditions (acid, alkaline or saline conditions) further confirmatory evidence or tests will be necessary as determined by the Approval Body.

Durability tests are only necessary for components of the product that have a function after installation in the works.

In determining suitability of a component or material in a particular application the Approval Body shall take due account of the consequences of failure, in particular related to the costs of access and the associated dismantling of the building.

##### **2.4.13.1.1.2 Durability of materials/products covered by a standard (e.g. metal or plastic components)**

###### **2.4.13.1.1.2.1 Painted/coated steel**

The adequacy of a coating on steel shall be assessed by reference to EN ISO 12944 in its various parts.

###### **2.4.13.1.1.2.2 Galvanised and aluminium coated steel**

The adequacy of zinc or aluminium corrosion protection shall be assessed by reference to EN ISO 14713, which gives general recommendations on corrosion protection.

###### **2.4.13.1.1.2.3 Coil-coated steel**

Coil-coated steel shall be assessed by reference to EN 10169.

###### **2.4.13.1.1.2.4 Coil-coated aluminium**

Coil-coated aluminium shall be assessed by reference to EN 1396.

###### **2.4.13.1.1.2.5 Stainless steel**

Stainless steels shall be classified by reference to EN 10088:2005. Annex B of EN 10088-1:2005 contains general guidance on the use of stainless steels including the aspect of corrosion resistance.

**Note 7:** Austenitic stainless steel: The most common alloys are 1.4301 (X5CrNi18-10) and 1.4401 (X5CrNiMo17-12-2). These austenitic stainless steels are normally suitable for use in all use categories as defined in 1.2. However, where high chloride contents or more severe conditions are likely to be present in the environment (e.g. rooms with indoor swimming pools, facades in cities with heavy traffic, in coastal areas), alloys with higher molybdenum content, e.g. 1.4429 (X2CrNiMoN17-13-3), 1.4539 (X1NiCrMoCu25-20-5) or 1.4529 (X1NiCrMoCuN25-20-7), may be necessary.

Austenitic-ferritic steels, e.g. 1.4462 (X2CrNiMoN22-5-3), are comparable to a CrNiMo-steel with 2,5 % to 3 % Mo.

Thermoplastic polymeric materials used in these products are generally used to form cover plates, frames etc. and thus do not fulfil a primary function. It is therefore sufficient to ensure that the component/material possesses characteristics that define it as being an acceptable quality moulding or extrusion. An exception may arise where a component has an aesthetic function and retention of appearance is important. However, performance in this respect is not regulated and falls outside the scope of this ETAG.

Extruded profiles in PVC-U shall be designated and assessed for suitability using EN 13245-1 and the associated tests in EN 13245-2. These standards allow a distinction to be made between profiles that are to be externally exposed and those that are for internal use only.

For injection moulded components, the effects of heating shall be determined, as a measure of quality, using the method described in EN 580, on 3 samples selected from each of 5 production batches.

After conditioning, no weld line shall have opened completely and no cracks or de-lamination shall penetrate more than 50 % of the thickness, at the point of injection. If 1 of any 3 samples exhibits a failure a retest may be undertaken on 6 further components. If any of these samples fails the product shall be deemed unacceptable.

#### 2.4.13.1.1.2.7 Mineral wool

Mineral wool complying with those requirements of EN 13162:2010 or EN 14303:2010 which are related to durability is deemed to satisfy the durability requirements for use categories Z<sub>1</sub>, Z<sub>2</sub>, Y<sub>1</sub> and Y<sub>2</sub>.

### 2.4.13.1.1.3 Materials/products not covered by a standard

#### 2.4.13.1.1.3.1 General

The principle of the durability tests is to take the product properties listed in the subsequent tables and to check whether these properties are changed after exposure of the product to defined exposure conditions.

#### 2.4.13.1.1.3.2 The properties to assess are:

- *Fabrics – non-elastic (folded etc.):*

<i>Property</i>	<i>Test method</i>
Appearance	B.12
Tear strength of fabric	B.5.4.1

- *Foam (foamed in-situ), non-reactive:*

<i>Property</i>	<i>Test method</i>
Appearance	B.12
Density of cured foam	B.6.2 (trimmed surfaces)
Loss of mass to determine a "corrosion rate"	B.15

- *Foam (foamed in-situ), containing reactive components:*

<i>Property</i>	<i>Test method</i>
Appearance	B.12
Density of cured foam	B.6.2 (trimmed surfaces)
Expansion ratio <sup>11</sup>	See EOTA TR 024: 07/2009, clause 3.1.11

- *Membrane-forming coatings:*

See sealants.

<sup>10</sup> This assessment is not intended to assess the durability and tightness of wrappings/casings used to protect reactive materials that are not durable on their own. These are assessed as part of the reactive component.

<sup>11</sup> Only for intumescent products

- *Mortar (cement based) and Plaster (gypsum based):*

<i>Property</i>	<i>Test method</i>
Appearance	B.12
Compressive strength	B.5.1.1 / B.5.1.2

The specimens shall be made from the same batch of material at the same time. Fully cured specimens shall be used for the exposure. The reference specimens shall be stored under standard conditions ( $23 \pm 3$  °C,  $50 \pm 5$  % RH) and tested together with the exposed specimens.

- *Sealants:*

Use categories regarding environmental conditions  $Z_1$  and  $Z_2$  are covered when tests according to ISO 7389, ISO 8339 or ISO 8340 and ISO 9046 or ISO 9047 are successfully carried out using conditioning method B for all tests (see the relevant part of Annex B).

For use categories X,  $Y_1$  and  $Y_2$  the same test procedure shall be applied but instead of conditioning method B the relevant exposure conditions according to clause 2.4.13.1.1.3.3 shall be used.

- *Strips, compressible (including composite), non-reactive*

Strips made from mineral wool complying with the requirements of EN 13162:2010 are deemed to satisfy the durability requirements for use categories  $Z_1$ ,  $Z_2$ ,  $Y_1$  and  $Y_2$ .

Other materials:

<i>Property</i>	<i>Test method</i>
Appearance	B.12
Compression set	B.14

- *Strips, compressible (including composite), reactive or containing reactive components / ingredients*

<i>Property</i>	<i>Test method</i>
Appearance	B.12
Expansion ratio	See EOTA TR 024, 07/2009 clause 3.1.11
Compression set	B.14

- *Strips, elastomeric:*

<i>Property</i>	<i>Test method</i>
Appearance	B.12
Tensile strength	B.5.2.1

- *Self-levelling joint fillers:*

See sealants.

- *Adhesives:*

ISO 10354 shall be used to characterise the durability of adhesives.

#### 2.4.13.1.1.3.3 Exposure conditions

- Use category related to environmental conditions type X:  
See EOTA TR 024: 07/2009, clause 4.2.3
- Use category related to environmental conditions type  $Y_1$ :  
See EOTA TR 024: 07/2009, clause 4.2.4
- Use category related to environmental conditions type  $Y_2$ :  
See EOTA TR 024: 07/2009, clause 4.2.5
- Use category related to environmental conditions type  $Z_1$ :  
See EOTA TR 024: 07/2009, clause 4.2.6
- Use category related to environmental conditions type  $Z_2$ :

See EOTA TR 024: 07/2009, clause 4.2.7

#### **2.4.13.1.1.4 Component and materials compatibility**

The Approval Body shall examine the design of the linear joint seal and make an assessment, using well-established principles, of the suitability of materials in contact. It is impossible to prescribe all the possible risk areas but these include for example the possibility of bi-metallic corrosion, the effects of wood preservatives on metals and the effects of solvent based coatings on the impact strength of plastics.

#### **2.4.13.1.2 Method of assessing and judging**

##### **2.4.13.1.2.1 Materials/products covered by a standard**

When the material/product (e.g. metal parts or other components) meet the relevant requirements given in the standards referenced they are considered being durable.

##### **2.4.13.1.2.2 Materials/products not covered by a standard**

As repeatability and reproducibility of most of the test methods used to determine relevant properties are unknown, a deviation of the mean values of the property assessed before and after exposure of not more than 15% is taken as a positive result of the durability assessment.

Alternatively where the result falls outside the 15% requirement, an assembly for an indicative resistance to fire test may be exposed to the relevant exposure conditions and afterwards tested according to EN 1366-4, EN 1364-3 or EN 1364-4.

#### **2.4.13.2 Serviceability**

##### **2.4.13.2.1 Movement capability<sup>12</sup>**

For a general introduction to the assessment approach see Annex B.13.

##### **2.4.13.2.1.1 Method of verification**

Details for the various types of products are given in:

- Annex B.13.2 - Adhesive-fixed products (AF)
- Annex B.13.3 - Friction-fixed products (FF)
- Annex B.13.4 - Mechanically fixed products (MF)
- Annex B.13.5 - Self-adhering products (SA)

##### **2.4.13.2.1.2 Method of assessing and judging**

Details for the various types of products are given in:

- Annex B.13.2 - Adhesive-fixed products (AF)
- Annex B.13.3 - Friction-fixed products (FF)
- Annex B.13.4 - Mechanically fixed products (MF)
- Annex B.13.5 - Self-adhering products (SA)

#### **2.4.13.2.2 Cycling of perimeter seals for curtain walls**

##### **2.4.13.2.2.1 Method of verification**

The test construction shall be subject to cycling a minimum of 500 times between the minimum and maximum joint width corresponding to the movement capability for a certain nominal joint width. Cycling shall start at the nominal joint width and finish at the maximum joint width. Cyclic rates of 30 cpm (cycles per minute) shall be designated as seismic, cyclic rates of 10 cpm shall be designated wind sway, and those rates below 1 cpm shall be designated thermal. The applicant shall designate a cyclic rate that shall be recorded in the test report.

After cycling, the test construction shall be allowed to stabilise for 24 hours, without alteration before fire testing, if not, the reasons shall be stated in the report.

##### **2.4.13.2.2.2 Method of assessing and judging**

Joint seals tested at a higher frequency are deemed to perform at lower frequencies.

---

<sup>12</sup> Only where movement capability performance is claimed by the applicant

Compression set data shall be provided on test specimens relying solely upon compression for placement in joints to satisfy long term performance.

The resistance against movement is given as "cycle tested at 30 cpm", "cycle tested at 10 cpm", or "cycle tested at 1 cpm".

### **2.4.13.3 Compression set**

#### **2.4.13.3.1 Method of verification**

It is relevant for mineral wool (AF, FF, MF) and compressible strips (including laminated, impregnated and composite) (AF, FF, MF), for movement as well as for non-movement joints. For details of the test method see B.14.

**Note 8** Necessary also for mechanically supported systems (if a gap is created by failure to recover after compression the fire resistance function may no longer be given).

#### **2.4.13.3.2 Method of assessing and judging**

See Annex B.14.

### **2.4.13.4 Linear expansion on setting**

#### **2.4.13.4.1 Method of verification**

Relevant for gypsum based mortars. For details of the test method see Annex B.11.2.

#### **2.4.13.4.2 Method of assessing and judging**

See Annex B.11.2.

### 3 EVALUATION AND ATTESTATION OF CONFORMITY AND CE MARKING

#### 3.1 System of attestation of conformity

See Part 1 – "General"

#### 3.2 Tasks and responsibilities for the manufacturer and notified bodies

##### 3.2.1 Tasks for the manufacturer

The corner stones of the actions to be undertaken by the manufacturer of the Fire Stopping and/or Fire Sealing Product in the procedure of attestation of conformity are laid down in Part 1 – "General" and in Table 3.

**Table 3 - Control plan for the manufacturer; corner stones**

Nr	Subject/type of control (product, raw/constituent material, component – indicating characteristic concerned)	Test or control method	Criteria, if any	Minimum number of specimens 13	Minimum frequency of control <sup>14</sup>
<b>Factory production control (FPC)</b>					

**Table 3.1 Fabrics**

1	Type of material(s)	check specification	-	see	1/b or 1/day
2	Dimensions, if relevant	B.10	-	see	1/b
3	Tear strength of fabric	B.5.4.1	-	see	1/b or 1/day
3	TGA or DTA <sup>15</sup>	B.2	-	see	1/10 b
4	Content of non-volatile components	B.3	-	see	1/10 b
5	Loss of mass on heating	B.4	-	see	1/10 b
6	Tear strength of seams (if relevant)	B.5.4.2	-	see	1/b
7	Mass per unit area of fabric	B.6.6	-	see	1/b or 1/day
8	Loss of mass on heating	B.4			1/b or 1/day

**Table 3.2 Foams in-situ applied**

1	TGA or DTA	B.2	-	see	1/10 b
2	Content of non-volatile components	B.3	-	see	1/10 b
3	Loss of mass on heating	B.4	-	see	1/10 b
4	Density of cured foam	B.6.2	-	see	1/b
5	Expansion ratio	EOTA TR 024: 07/2009, clause 3.1.11	-	see	1/b

<sup>13</sup> One specimen is normally considered to be sufficient. The final number of specimens is to be defined in the ETA or accompanying documents.

<sup>14</sup> The abbreviations given stand for the frequency of tests: 1/b = once per batch, 1/10 b = once per 10 batches, 1/6 m = once per 6 month, 1/h = once per hour, decl = declaration of conformity provided by the supplier of the component(s);

batch:

for continuous production the frequency shall be defined by the EOTA body on a case by case basis depending on the peculiarities of the manufacturing process and the level of quality management system installed:

for discontinuous production: a batch is the specific amount of material produced at one time using the same process and the same conditions of manufacture.

<sup>15</sup> Method 1 or methods 2 plus 3 may be chosen alternatively but the frequency may be further reduced if the components / raw materials and their related mass is recorded automatically (e.g. by means of an automatically recording balance) and an appropriate quality management system is installed.

6	Curing behaviour (tack free time)	B.9.1	-	see	1/b
7	Dimensional stability (change in volume)	B.11	-	see	1/10b <sup>16</sup>

**Table 3.3 Membrane-forming coatings**

1	TGA or DTA	B.2	-	see	1/10b
2	Content of non-volatile components	B.3	-	see	1/10b
3	Loss of mass on heating	B.4	-	see	1/10b
4	Viscosity of liquid material	B.7	-	see	1/b
5	Density of liquid material	B.6.1	-	see	1/b
6	Expansion ratio	EOTA TR 024: 07/2009, clause 3.1.11	-	see	1/b

**Table 3.4 Mineral wool boards/slabs/batts/strips**

Mineral wool manufactured according to EN 14303:2010 or EN 13162:2010 <sup>17</sup>					
1	see EN 14303:2010 or EN 13162:2010 Annex B		-	see	
2	Apparent density	B.6.3	-	see	1/h
3	"Melting" point	one of the methods of B.8 shall be used	-	see	1/b of raw material
4	Thickness of facing or mass per unit area of facing, if relevant	B.10.1	-	see	decl (every delivery)
Mineral wool not manufactured according to EN 14303:2010 or EN 13162:2010					
1	Apparent density	B.6.3	-	see	1/h
2	"Melting" point	B.8	-	see	1/b of raw material
3	See EN 13162:2010 Annex B <sup>18</sup>		-	see	
4	Thickness of facing or mass per unit area of facing, if relevant	B.10.1	-	see	decl (every delivery)

<sup>16</sup> Depending on how close the result of the approval test is to the threshold value of the specification

<sup>17</sup> Products produced according to EN 13162:2010 may be suitable for linear joint seal applications but melting point and density are properties relevant for this application which are not covered in EN 13162:2010.

<sup>18</sup> The following properties are not considered essential for the fire resistance performance: thermal resistance, thermal conductivity, durability, compressive stress or strength, water absorption, water vapour transmission, small amount of water soluble ions and pH-value.



**Table 3.5 Mortar (cement based or gypsum based)**

1	TGA or DTA	B.2	-	see	1/10b
2	Content of non-volatile components	B.3	-	see	1/10b
3	Loss of mass on heating	B.4	-	see	1/10b
4	Non-compacted bulk density	B.6.4	-	see	1/b
5	Setting time	B.9.2	-	see	1/b
6	Compressive strength after 3 or 7 days (cement based), if relevant	B.5.1	-	see	1/b
7	Compressive strength after 28 days (cement based), if relevant	B.5.1	-	see	1/6m
8	Compressive strength after 24 hours - fully saturated (gypsum based), if relevant	B.5.1	-	see	1/b
9	Compressive strength fully dried (gypsum based), if relevant	B.5.1	-	see	1/6m

**Table 3.6 Sealants / mastics and putties**

1	TGA or DTA	B.2	-	see	1/10b
2	Content of non-volatile components	B.3	-	see	1/10b
3	Loss of mass on heating	B.4	-	see	1/10b
4	Density of uncured ("liquid") material	B.6.1	-	see	1/b
5	Viscosity of uncured ("liquid") material	B.7	-	see	1/b
6	Hardness after curing, if relevant	B.5.3.1	-	see	1/10b
7	Expansion ratio	EOTA TR 024: 07/2009, clause 3.1.11	-	see	1/b

**Table 3.7 Strips, compressible (including composite, laminated, impregnated)**

1	Dimensions (including laminations etc.)	B.10	-	see	1/b
2	Density before lamination / impregnation (degree of impregnation) etc., if relevant	B.6.5	-	see	1/b or decl
3	Density after lamination / impregnation (degree of impregnation) etc., if relevant	B.6.5	-	see	1/b
4	Expansion ratio	EOTA TR 024: 07/2009, clause 3.1.11	-	see	1/b

**Table 3.8 Strips, elastomeric**

1	TGA or DTA	B.2	-	see	1/10b
2	Content of non-volatile components	B.3	-	see	1/10b
3	Loss of mass on heating	B.4	-	see	1/10b
4	Density of cured material	B.6.5	-	see	1/b
5	Hardness after curing or tensile strength	B.9.1 B.5.2.1	-	see	1/10b

**Table 3.9 Self-levelling joint fillers - non-intumescent**

See sealants

### 3.2.2 Tasks for notified bodies

The corner stones of the actions to be undertaken by the notified body (bodies) in the procedure of attestation of conformity for Fire Stopping and/or Fire Sealing Products are laid down in Table 4.

#### 3.2.2.1 Initial type-testing of the product (ITT)

Direct tests related to the properties listed in the mandate (fire resistance, mechanical resistance and stability, adhesion, resistance to impact/movement, release of dangerous substances) will already have been done as part of the approval tests and it will not normally be necessary for these to be repeated for ITT. However, depending on the degree to which the samples used for the approval testing were representative of the product produced under the conditions of current production (e.g. when prototypes were used), some confirmatory tests may need to be done out of the list given in Table 4.

#### 3.2.2.2 Initial inspection of factory and factory production control (FPC)

The relevant properties are listed in Table 4.

#### 3.2.2.3 Continuous surveillance, judgment and assessment of factory production control (FPC)

The relevant properties are listed in Table 4. The minimum surveillance frequency is normally twice a year.

**Table 4 - Control plan for the notified body (bodies); corner stones**

Subject/type of control	Test or control method	Criteria, if any	Minimum number of specimens	Minimum frequency of control
<b>Initial type-testing of the product (ITT)</b>				
See clauses 2.4.1 to 2.4.13, and Table 5 The approval tests are usually acceptable for ITT				
<b>Initial inspection of factory and factory production control (FPC)</b>				
See Part 1 – "General" and Table 3 of this Part				
<b>Regular surveillance, judgment and assessment of factory production control (FPC)</b>				
See Part 1 – "General" and Table 3 of this Part				

### 3.2.3 Special methods of control and testing used for the evaluation

See Annex B

### 3.3 CE marking and accompanying information

See Part 1 – "General"

Example of CE marking and accompanying information:

 1234	"CE" marking  Identification number of notified certification body
Any Company Street 1, City, Country 04 1234-CPD-0321	Name and address of the producer (legal entity responsible for the manufacturer)  Two last digits of year of affixing CE marking Number of EC certificate of conformity
ETA-011/XYZZ ETAG 026 – Part 3 Linear joint seal "XXX" see ETA-11/1234 for relevant characteristics"	ETA number ETAG number  Name Reference to ETA for relevant characteristics

## 4 ASSUMPTIONS UNDER WHICH THE FITNESS FOR THE INTENDED USE IS ASSESSED

### 4.1 Manufacture of the product

No specific provisions.

### 4.2 Packaging, transport, storage of the product

For general advice see Part 1 – "General".

When the product, as delivered, has a limited shelf life, it is assumed that the manufacturer gives a clear indication of that life and, when appropriate, restrictions on the storage conditions (e.g. temperature, humidity).

### 4.3 Installation of the product in the works

#### 4.3.1 Information accompanying the product

It is assumed that the manufacturer shall provide information on:

- the use conditions in terms of environmental conditions (e.g. dry indoor use) as covered by the ETA
- the method of preparation of the supporting construction (wall/floor) before installation of the linear joint or gap seal

### 4.4 Use, maintenance, repair

It is assumed that the manufacturer shall provide information for the installer on the method of repair or replacement in case of damage to the linear joint seal.

### 4.5 Auxiliary components

See Part 1 – "General"

## 5 IDENTIFICATION OF THE CONSTRUCTION PRODUCT

### 5.1 Means of identification

All components of the Fire Stopping and Fire Sealing Products shall be clearly identified in accordance with section 5 of Part 1 – "General" of this ETAG. Wherever possible a harmonised European Technical Specification shall be used to identify the component. If the product is a reactive material, the EOTA TR 024 has to be taken into account. For products not covered by a harmonised European Technical Specification or the EOTA TR024: see part 1 – "General" and the following:

When the option "Fingerprinting" is taken, for most products an IR (e.g. Fourier Transform Infra-Red Spectroscopy) plus a TGA (Thermo-gravimetric Analysis) or DTA (Differential Thermal Analysis) will be appropriate.<sup>19</sup>

Alternatively, or in addition, the applicant, or a third party at his request, may disclose the formulation to the EOTA body for identification purposes.

For the purpose of testing of physical characteristics the properties listed in Table 5 shall be determined depending on the type of the product. The test methods given are recommendations only.<sup>19</sup>

Description of the visual appearance, type of material(s) and dimensions will be useful information for identification.

Drawings will be useful particularly for products that are formed or contain formed components or for products that are characterised by a specific geometrical shape, dimensions etc.

In many cases a combination of the options will be required to cover all aspects.

**Table 5 – Physical product characteristics, methods of verification and criteria used for checking the product identity**

**Table 5.1 Fabrics**

Number	Product characteristic	Verification method
1	Dimensions (if relevant)	B.10
3	Tear strength of fabric and (if relevant) seams	B.5.4.1
4	Mass per unit area of fabric	B.6.6
5	Mass per unit length of seam thread, if relevant	

**Table 5.2 Foams (in-situ applied)**

Number	Product characteristic	Verification method
1	TGA or DTA	B.2
2	Content of non-volatile components	B.3
3	Loss of mass on heating	B.4
4	Curing behaviour (tack free time)	B.9.1
5	Density of cured foam	B.6.2
6	Expansion ratio	EOTA TR 024: 07/2009, clause 3.1.11

**Table 5.3 Membrane-forming coatings**

Number	Product characteristic	Verification method
1	TGA or DTA	B.2
2	Content of non-volatile components	B.3
3	Loss of mass on heating	B.4
4	Expansion ratio	EOTA TR 024: 07/2009, clause 3.1.11

**Table 5.4 Mineral wool boards/slabs/batts/strips**

Number	Product characteristic	Verification method
Mineral wool manufactured according to EN 14303:2010 or EN 13162:2010		
1	see EN 14303:2010 or EN 13162:2010 for characteristics relevant for this ETA	

<sup>19</sup> There are three options to identify the single components of a product: by "fingerprinting" (combination of TGA/DTA and IR; by depositing the composition and formulation or by verifying physical characteristics). The latter may include a combination of TG or DTA plus loss of mass on heating/non-volatile components and density or other parameters.

2	Apparent density	B.6.3
3	“Melting” point	One method from B.8 shall be selected
Mineral wool not manufactured according to EN 14303:2010 or EN 13162:2010		
1	Apparent density	B.6.3
2	“Melting” point	One method from B.8 shall be selected
3	See EN 13162:2010, Annex B	

**Table 5.5 Mortar (cement based) and Plaster (gypsum based)**

Number	Product characteristic	Verification method
1	TGA or DTA	B.2
2	Content of non-volatile components	B.3
3	Loss of mass on heating	B.4
4	Non-compacted bulk density	B.6.4
5	Compression strength after 28 days (cement based), if relevant	B.5.1
6	Compression strength fully dried state (gypsum based), if relevant	B.5.1

**Table 5.6 Sealants/mastics and putties**

Number	Product characteristic	Verification method
1	TGA or DTA	B.2
2	Content of non-volatile components	B.3
3	Loss of mass on heating	B.4
4	Hardness after curing, if relevant	B.5.3.1
5	Expansion ratio	EOTA TR 024: 07/2009, clause 3.1.11

**Table 5.7 Strips, compressible (including composite, laminated, impregnated)**

Number	Product characteristic	Verification method
1	Dimensions (including laminations etc.)	B.10
2	Density after lamination / impregnation (degree of impregnation) etc., if relevant	B.6.5
3	Expansion ratio	EOTA TR 024: 07/2009, clause 3.1.11

**Table 5.8 Strips, elastomeric**

Number	Product characteristic	Verification method
1	TGA or DTA	B.2
2	Content of non-volatile components	B.3
3	Loss of mass on heating	B.4
4	Density of cured material	B.6.5
5	Tensile strength	B.5.2.1

**Table 5.9 Self-levelling joint fillers - non-intumescent**

See sealants

## 5.2 Product characteristics which are relevant for identification checking

See tables 5.1 to 5.9 and the related verification methods in Annex B referenced in the tables.

## 6 FORMAT OF ETAS ISSUED ON THE BASIS OF THE ETAG

European technical approvals issued on the basis of this ETAG shall be in accordance with the ETA format given in the Addendum to this ETAG.

## 7 REFERENCE DOCUMENTS

This ETA-Guideline N° 026, part 3 incorporates, by dated or undated reference, provisions from other publications. These normative references are cited at the appropriate places in the text and the publications are listed below. For dated references subsequent amendments to, or revisions of these publications, apply to this ETAG only when incorporated in it by amendment or revision. For undated references the latest dated revision of the publication referred to, applies.

For further updating conditions see Part 1 – "General" - Foreword.

### 7.1 EC Documents

Commission Decision 96/603/EC	Commission Decision of 4 October 1996 establishing the list of products belonging to Classes A 'No contribution to fire' provided for in Decision 94/611/EC implementing Article 20 of Council Directive 89/106/EEC on construction products
Commission Decision 2000/605/EC	Commission Decision of 26 September 2000 amending Decision 96/603/EC establishing the list of products belonging to Classes A 'No contribution to fire' provided for in Decision 94/611/EC implementing Article 20 of Council Directive 89/106/EEC on construction products
Commission Decision 2003/424/EC	Commission Decision of 6 June 2003 amending Decision 96/603/EC establishing the list of products belonging to Classes A 'No contribution to fire' provided for in Decision 94/611/EC implementing Article 20 of Council Directive 89/106/EEC on construction products

### 7.2 Product Specifications

ETAG 026:01/2008	Fire Stopping and Fire Sealing Products - Part 1 – "General"
EN 520	Gypsum plasterboards, Definition, requirements and test methods
EN 1396	Aluminium and aluminium alloys - Coil coated sheet and strip for general applications - Specifications
EN 10088:2005	Stainless steels – Part 1: List of stainless steels Part 2: Technical delivery conditions for sheet/plate and strip of corrosion resisting steels for general and construction purposes Part 3: Technical delivery conditions for semi-finished products, bars, rods, wire, sections and bright products of corrosion resisting steels for general and construction purposes
EN 10169	Continuously organic coated (coil coated) steel flat products – Part 1: General information (definitions, materials, tolerances, test methods) Part 2: Products for building exterior applications Part 3: Products for building interior applications
EN 13162:2010	Thermal insulation products for buildings – Factory made mineral wool (MW) products – Specification
EN 13245	Plastics – Unplasticized poly vinyl chloride (PVC-U) profiles for building applications – Part 1: Designation of light coloured profiles Part 2: Profiles for internal and external wall and ceiling finishes

EN ISO 12944	Paints and varnishes - Corrosion protection of steel structures by protective paint systems – Part 1: General introduction Part 2: Classification of environments Part 3: Design considerations Part 4: Types and surface preparation Part 5: Protective paint systems Part 6: Laboratory performance test methods Part 7: Execution and supervision of paint work Part 8: Development of specifications for new work and maintenance
EN 14303:2010	Thermal insulation products for building equipment and industrial installations; Factory made mineral wool products (MW); Specification
EN ISO 14713	Protection against corrosion of iron and steel in structures - Zinc and aluminium coatings - Guidelines

### 7.3 Test methods and classification standards

EN 196-3	Methods for testing cement – Part 3: Determination of setting time and soundness
EN ISO 580	Plastics piping and ducting systems – Injection-moulded thermoplastics fittings – Methods for visually assessing effects of heating
EN 1015-11	Methods of test for mortars for masonry – Part 11: Determination of flexural and compressive strength of hardened mortar
EN 1026:2000	Windows and doors – Air permeability – Test method
EN 1364	Fire resistance tests for non-loadbearing elements  Part 3: Curtain walling; Full configuration (complete assembly) Part 4: Curtain walling – Part configuration
prEN 1366-3:2006	Fire resistance tests for service installations, Part 3: Penetration seals
EN 1366-4	Fire resistance tests for service installations, Part 4: Linear joint seals
EN 1426	Bitumen and bituminous binders - Determination of needle penetration
EN 1602	Thermal insulating products for building applications – Determination of the apparent density
EN 1634-3:2005	Fire resistance tests for door and shutter assemblies – Part 3: Smoke control doors and shutters
EN 12092	Adhesives – Determination of viscosity
EN 12154	Curtain walling – Watertightness – Performance requirements and classification
EN 12155	Curtain walling – Watertightness – Laboratory test under static pressure
EN 13238	Reaction to fire tests for building products: Conditioning procedures and general rules for selection of substrates
EN 13501	Fire classification of construction products and building elements Part 1: Classification using test data from reaction to fire tests Part 2: Classification using test data from fire resistance tests
EN 13823	Reaction to fire tests for building products – Building products excluding – floorings – Thermal attack by a single burning item
EN 14706	Thermal insulation products for building equipment and industrial insulation – Determination of maximum service temperature
EN 29073-1	Textiles; test method for nonwovens - Part 1: Determination of mass per unit area
EN ISO 527-2	Plastics – Determination of tensile properties – Part 2: Test conditions for moulding and extrusion plastics
EN ISO 2811	Paints and varnishes – Determination of density – Part 1: Pyknometer method Part 2: Immersed body (plummet) method Part 3: Oscillation method

EN ISO 3219	Plastics – Polymers/resins in the liquid state or as emulsions or dispersions – Determination of viscosity using a rotational viscometer with defined shear rate
EN ISO 3251	Paints, varnishes and plastics – Determination of non-volatile-matter content
EN ISO 3451	Plastics – Determination of ash Part 1: General methods Part 4: Polyamides Part 5: Poly(vinyl chloride)
EN ISO 11925-2	Reaction to fire tests – Ignitability of building products subjected to direct impingement of flame – Part 2: Single-flame source test
EN ISO 13934-1	Tensile properties of fabrics – Part 1: Determination of maximum force and elongation at maximum force using the strip method
EN ISO 13935	Seam tensile properties of fabrics and made-up textile articles – Part 1: Determination of maximum force to seam rupture using the strip method Part 2: Determination of maximum force to seam rupture using the grab method
EOTA TR 001:02/2003	Determination of impact resistance of panels and panel assemblies
EOTA TR 024:07/2009	Characterisation, Aspects of Durability and Factory Production Control for Reactive Materials, Components and Products
ISO 37	Rubber, vulcanized or thermoplastic – Determination of tensile stress-strain properties
ISO 3049	Gypsum plasters – Determination of physical properties of powder
ISO 7389	Building construction – Jointing products – Determination of elastic recovery of sealants
ISO 7390	Building construction – Jointing products – Determination of resistance to flow of sealants
ISO 7619	Rubber, vulcanized or thermoplastic – Determination of indentation hardness – Part 1: Durometer method (Shore hardness) Part 2: IRHD pocket meter method
ISO 8339	Building construction – Jointing products – Sealants – Determination of tensile properties
ISO 8340	Building construction – Jointing products – Sealants – Determination of tensile properties at maintained extension
ISO 9046	Building construction – Jointing products – Determination of adhesion / cohesion properties of sealants at constant temperature
ISO 9047	Building construction – Jointing products – Determination of adhesion / cohesion properties of sealants at variable temperatures
ISO 10563	Building construction – Sealants for joints – Determination of change in mass and volume
ISO 11600	Building construction - Sealants - Classification and requirements
<b>7.4 Others</b>	
EN ISO 13788	Hygrothermal performance of building components and building elements - Internal surface temperature to avoid critical surface humidity and interstitial condensation - Calculation methods



## ANNEX A

### Mounting and Fixing Procedures for Reaction to Fire Tests

#### A.1 Tests according to EN 13823 (SBI)

With linear joint seals a major concern of some regulators is vertical spread of flames and spread of flames into voids.

Vertical spread of flame is not directly used as a performance criterion in the SBI test.

However, by testing a specimen comprising the full area of the SBI rig (see figure A.1) as opposed to the normal format of a linear joint, the normal SBI data is useful in evaluating a potential vertical flame spread as the threshold values for FIGRA and THR are related to a situation where the full specimen area potentially contributes to the heat release.

The thickness of each component of the linear joint seal shall be representative of the installation in practice. The maximum thickness of 200 mm given in EN 13823 may be reduced, provided a minimum unaffected thickness of 10 mm of the product or component forming the surface is left after the test.<sup>20</sup>

Regarding the size of the specimen the standard configuration shown in figure A.1 is normally used.<sup>21</sup>

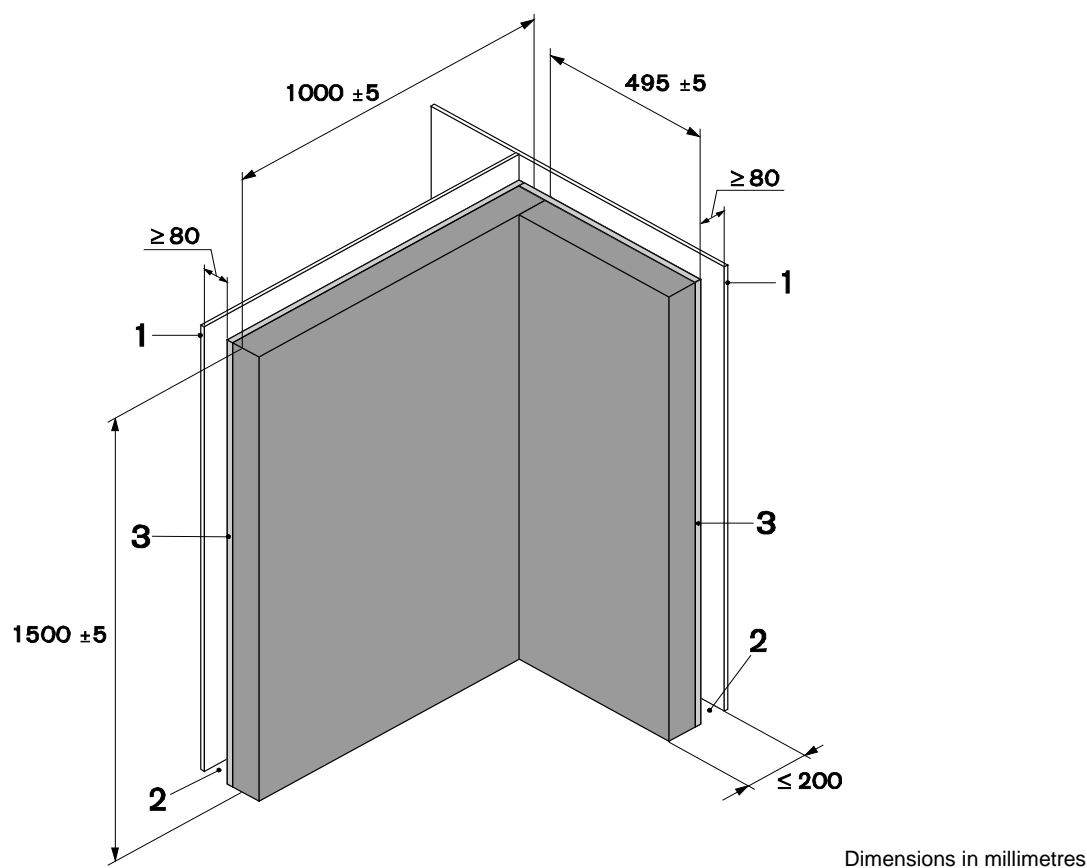

#### Key

- Specimen area
- 1 Backing boards
- 2 Air gap
- 3 Supporting board

**Figure A.1 – Standard configuration**

<sup>20</sup> This may be relevant for e.g. strips or composite strips. An indicative test, for example using a Bunsen burner will give an estimate of the necessary thickness.

<sup>21</sup> While not representative of the normal form of a linear joint seal in practice, an extended size of test specimen was chosen to allow a better observation of potential flame spread.

Where no lateral spread of flame is expected, outside the area on the long wing covered by the specimen, the configuration shown in Figure A.2 can be used alternatively. When in a test using the configuration according to figure A.2, lateral spread of flame outside this area is observed the test shall be repeated using the standard configuration according to A.1.

In cases where the specimen is to be built from a high number of relatively small parts (e.g. strips), they may be mechanically stabilized by fixing them, from the reverse side, to a supporting board made from calcium silicate.

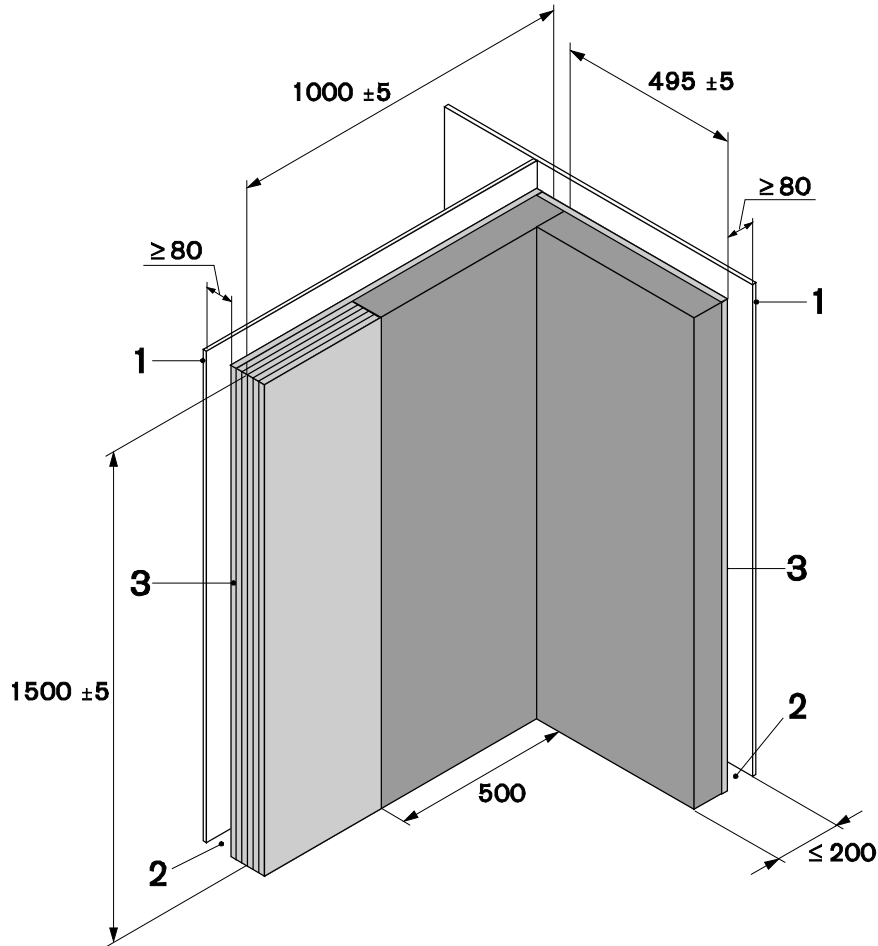

Dimensions in millimetres

**Key**

- Specimen area
- Calcium silicate board
- 1 Backing boards
- 2 Air gap
- 3 Supporting board

**Figure A.2 – Extended standard configuration**

When using the configuration according to Figure A.2 the part of the wing that is not covered by the test material shall be made of calcium silicate board.

## A.2 Tests according to EN ISO 11925-2 (small burner test)

The test shall be conducted according to EN ISO 11925-2 subject to the following provisions:

- The test specimen used shall simulate a joint seal. The joint faces are made from steel angles, calcium silicate or fibre cement board. An example for a set-up is shown in Figure A.3;
- The joint seal shall have the maximum nominal width applied for, subject to maximum 90 mm. The seal is tested without any backfilling material / backer rod;
- The smallest and the biggest depth<sup>22</sup> applied for shall be used. When the depth is smaller than 10 mm a backing board shall be used, made from calcium silicate.
- Any surface (face) that may be exposed in practice shall be tested;
- Where two adjacent surfaces forming an edge are exposed in practice, edge exposure shall be used;
- Compressed materials: The compression used in practice shall be simulated in the test. The result will only be valid for the equal or higher compression.
- For membrane forming coatings used on mineral wool (slabs) the standard mineral wool substrate according to EN 13238 shall be used. The thickness of the coating shall be the maximum of the range requested by the ETA applicant. If another substrate will be used in practice this substrate shall be used in the test. In the latter case the results are only valid for the substrate used in the test.

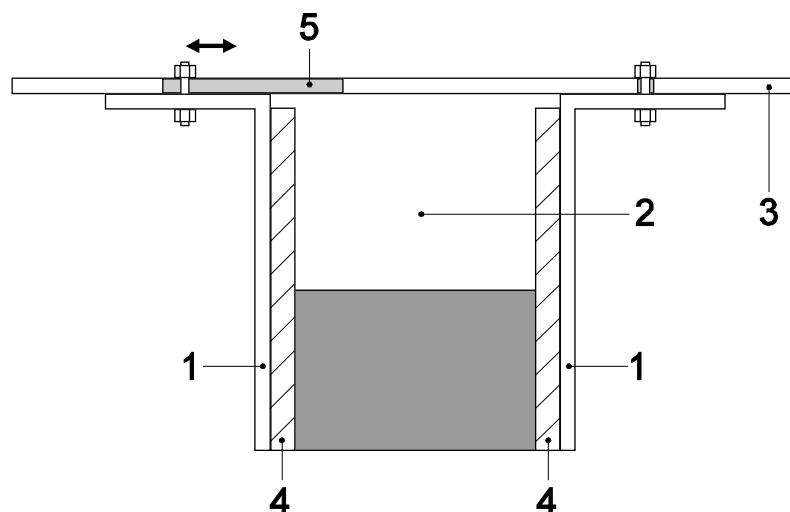

### Key

- Specimen
- 1 Steel angle
- 2 Air gap
- 3 Base plate
- 4 Calcium silicate
- 5 Slot to allow adjustment to different specimen width and compression

Figure A.3 – Example for a test setup for the small burner test

<sup>22</sup> The Approval Body can reduce the test amount for justified reasons (e.g. only to test the smallest depth if minimum and maximum depth do not vary essentially)

## ANNEX B

### Tests for the Aspects of Serviceability and Identification

#### **B.1 IR (Infra-Red Spectroscopy)**

Execute according to the instruction manual of the equipment used. See also EOTA TR 024:07/2009, Annex C.3 for details when used as identification method (Fingerprint).

#### **B.2 Thermo-analytical methods**

##### **B.2.1 Thermo-gravimetric Analysis (TGA)**

See EOTA TR 024: 07/2009, Annex C.2.

Where the method is used for Fingerprinting the prescribed heating rate, size of specimen, material of crucible and rinsing gas shall be used.

##### **B.2.2 DTA (Differential Thermal Analysis)**

**Note 9** This method is less suitable for intumescent materials than TGA, especially for the purpose of "Fingerprinting".

#### **B.3 Content of non-volatile components**

Test according to EN ISO 3251.

The value reported as a declared value for identification shall be the mean value of at least three specimens.

#### **B.4 Loss of mass on heating**

Test according to EN ISO 3451-1, subject to the following provisions: As loss of mass on heating is a characteristic of a material, protective foils or coatings shall be removed if at all possible. When the product is tested with a protective foil or coating this shall be recorded to ensure consistency with future tests.

The standard was written for plastics but other materials can also be tested following the principles of the standard.

The value reported as a declared value for identification shall be the mean value of at least three specimens.

#### **B.5 Mechanical properties**

##### **B.5.1 Compressive strength**

###### **B.5.1.1 Mortars (cement based)**

Test according to EN 1015-11.

The strength at 3, 7 or 28 days may be determined dependent on whether high early strength or normal cement is used.

###### **B.5.1.2 Plaster (gypsum based)**

Test according to EN 1015-11

This method may be applied to gypsum based products subject to the product being tested after 24 hours, fully saturated, and after oven drying at 30 to 35°C to constant mass (for conditioning see EN 13238).

##### **B.5.2 Tensile strength**

###### **B.5.2.1 Rubber, elastomeric strips**

Test according to ISO 37 or EN ISO 527-2.

##### **B.5.3 Hardness**

###### **B.5.3.1 Sealants (cured)**

Test according to ISO 7619 -1 or ISO 7619-2.

###### **B.5.3.2 Pre-foamed products**

A penetrometer is used with a steel ball of suitable diameter at the tip. The ball is positioned at the surface of the specimen (freshly cut surface) and then allowed to penetrate the material by means of a suitable weight on top. The depth of the penetration into the specimen is determined and given in the unit [mm].

Alternatively EN 1426 may be used.

## **B.5.4 Tear strength**

### **B.5.4.1 Fabrics**

EN ISO 13934-1

### **B.5.4.2 Seam**

EN ISO 13935-1 or EN ISO 13935-2

## **B.6 Density**

### **B.6.1 Sealants, membrane-forming coatings and other paste like materials**

Sealants, coatings and other paste like materials may be tested according to the principles of EN ISO 2811-1 (pycnometer). The mean value of 3 specimens and the standard deviation shall be reported. For FPC also EN ISO 2811-2 is a suitable method.

### **B.6.2 Foams (in-situ, cured foam)**

A cardboard beaker (coated with paraffin) is filled with the foam (take care of avoiding any holes and cavities). The foam is cut at the edge of the beaker after curing. The specimen shall be kept at ambient temperature. Density = mass total – mass beaker / volume of beaker (kg/m<sup>3</sup>). The mean value of 3 specimens and the standard deviation shall be reported.

### **B.6.3 Mineral wool**

Test according to EN 1602

### **B.6.4 Non-compacted bulk density (mortar)**

Test according to ISO 3049 subject to the following:

When preparing the sample the material is not passed through a 2 mm mesh sieve.

### **B.6.5 Pre-formed products**

The density is calculated from the mass and the volume of the specimen. The mass of the specimen shall be determined with a balance of an accuracy of 0.1g. The dimensions can be determined to the nearest mm either using a ruler when the product has a regular shape, or determining the volume by using a water displacement technique.

### **B.6.6 Mass per unit area of fabrics**

Test according to EN 29073-1.

## **B.7 Viscosity**

### **B.7.1 Liquids with high viscosity**

Test according to EN ISO 3219

### **B.7.2 Liquids with low viscosity**

Test according to EN 12092

## **B.8 Behaviour of mineral wool at high temperature (for identification and FPC)**

### **B.8.1 Visual method of determining the "Melting point"**

A sample of the mineral wool shall be pre-treated at 550 ± 10 °C in a muffle furnace until the organic binder will be eliminated. Cut cube specimens of 10 mm x 10 mm x 10 mm from the pre-treated sample.

The cube specimens are inserted into a tube furnace having an internal diameter of 25 mm pre-heated to a temperature approximately 30 degrees below the expected melting temperature. This is achieved by placing the specimen on a suitable carrier (e.g. a metal or ceramic pin or spatula) which is supported outside the tube furnace. The specimen is moved slowly to the centre of the furnace, where the temperature sensor is located. The specimen is held for 10 minutes in that position. The specimen is then carefully removed from the furnace and examined to see whether it has melted. The furnace temperature is noted.

If the specimen is unchanged, raise the furnace temperature by 10 degrees, wait until the temperature is stabilized and repeat the test with a new specimen.

If the specimen has melted, lower the temperature by 10 degrees and repeat the measurement with a new specimen. The temperature where the wool started melting is called the "melting" point.

The dimensions of the inner diameter of the tube furnace and the specimen may be changed provided the ratio is kept constant.

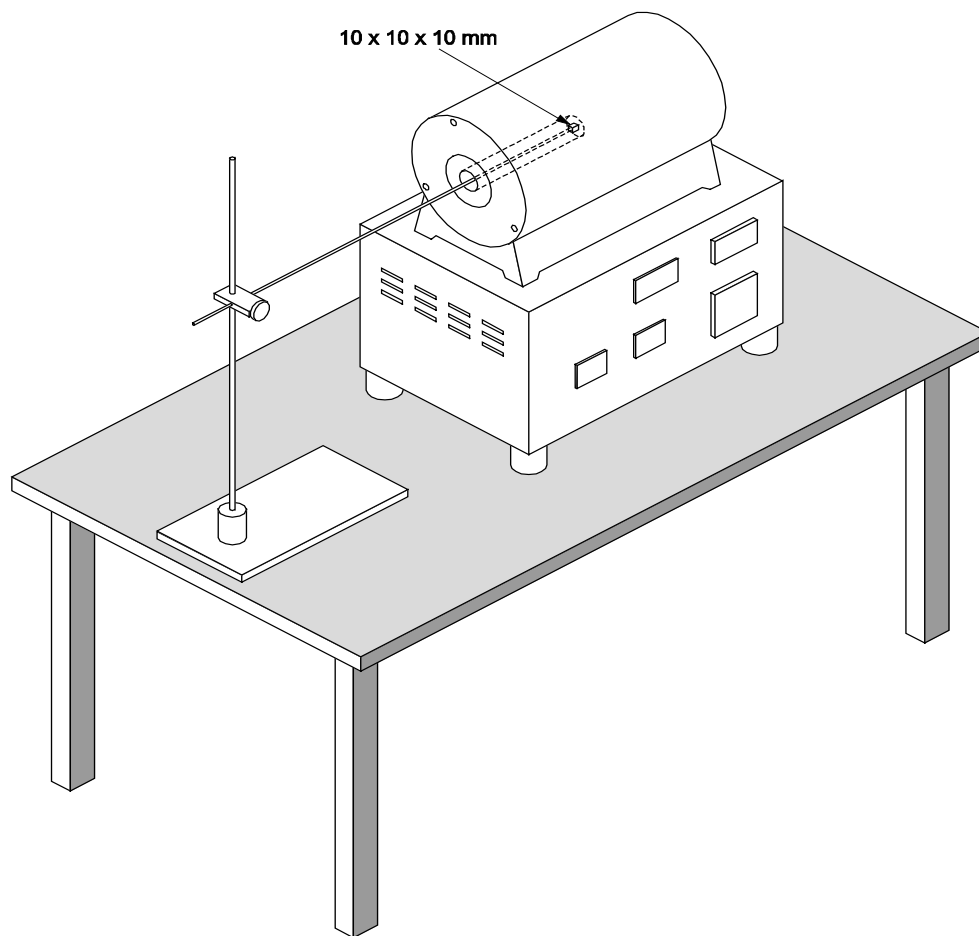

Figure B.1 –Setup for visual method

### B.8.2 Thermo-analytical methods (for FPC)

Any thermo-analytical method may be used, e.g. DTA or TGA.

### B.8.3 Chemical analysis (for FPC)

The details (definition of the elements/components to be determined) are to be agreed between the EOTA body and the manufacturer and to be outlined in the documentation accompanying the ETA.

### B.8.4 Determination of the melting point of mineral fibre insulating materials

This method is suitable for mineral fibre material to test whether its "melting point" is above a temperature of 1000°C.

#### Preparation

For every mineral fibre material use at least 2 dry samples.

Cut 2 specimen of 500 x 500 mm. The maximum thickness shall be 80 mm.

Dry at  $23 \pm 2$  and  $50 \pm 5\%$  RH until equilibrium (change in mass less than 0,1% within 24 hours).

Apply a steel-plate of a size of 200 mm x 200 mm and a mass of 0,4 kg (causing a pressure of  $0,1 \text{ kN/m}^2$ ) with a hole in the centre for determining the thickness of the material (round up to full millimetre).

The density of every specimen will be determined geometrically from mass and the geometrical dimensions.

#### Test procedure

Cover both sides of every specimen by a steel-sheet of a thickness of 1 mm and install them vertically into a small scale furnace and expose the specimen to a heat regime according to the standardized temperature-time curve according to EN 13501-2, clause 4.2, for 90 minutes.

The thickness shall be measured again after exposure (see **preparation**).

#### Test report and assessment

Following data shall be recorded:

- density (see B.6)
- thickness of the specimen before and after exposure to heat
- difference between thickness before and after exposure to heat
- visual appearance and changes in appearance after exposure to heat (description, photo etc.)

The change of thickness of both specimen shall be less than 50% for products having a "melting point" higher than 1000 °C.

## **B.9 Curing behaviour**

### **B.9.1 Tack free time of foams (identification and FPC)**

A suitable amount of the material is extruded in to a beaker. The surface of the foam is touched by means of a wooden spatula at suitable intervals. The tack free time is reached when no foam sticks on the spatula.

### **B.9.2 Setting time of mortar**

Test according to EN 196-3 subject to the following:

- Soundness is not relevant
- Setting time test: A penetration depth of 16-20 mm shall used for testing plaster based mortars
- Determination of final setting time is not relevant for plaster based mortars, as it is the working time to initial set which is critical to an end user and is the figure normally quoted in the product specification.

## **B.10 Dimensions**

### **B.10.1 Thickness**

The thickness of products in the form of plates, sheets, boards, strips, fabrics, foils etc. is determined by means of a suitable gauge to the nearest 0.1 mm at 5 locations of the specimen. The minimum size of the specimen is 10x10 cm or a minimum length of 50 cm in case of strips.

For foils and similar products / components thickness is determined to the nearest 0.01 mm.

### **B.10.2 Other dimensions**

The dimensions shall be determined to an accuracy of 0,5% by means of a suitable gauge.

## **B.11 Dimensional stability**

### **B.11.1 Foams**

#### **B.11.1.1 General**

Dimensional stability is a measurement of the resistance of a cured foam to shrink or post-expand after curing as measured in this test. The following protocol describes how to measure dimensional stability in a controlled testing environment.

#### **B.11.1.2 Required equipment**

- The application tool (e.g. dispenser) that belongs to the tested system
- Spacers (minimum 100 mm x (15 mm ± 1 mm) x 20 mm, made of dimensionally stable material (for example: PE, PTFE,...), on which polyurethane does not adhere.
- Exterior grade plywood, about 130 mm x 100 mm, so that a net foam area of 100 mm x 100 mm remains. The thickness of the plywood shall be minimum 9.5 mm and it shall have at least one sanded face.
- Hand clamps
- Suitable measuring gauge (± 0,5 mm)
- Knife
- Climatic chamber (controlled environment test equipment)
- Heating chamber, dry but unspecified relative humidity

#### **B.11.1.3 Testing**

The foam, the application tool, and the substrate shall be conditioned in accordance with EN 13238 to constant mass. Three specimens shall be made according to Figure B.1 and B.2. Be sure that the clamps sit directly on the spacers so as not to compress the assembly. The specimen shall have a gap with the required width of approximately 20 mm. The net foam space shall be an area of approximately 100 mm x 100 mm. Figure B.3 shows how the assembly shall be oriented during foaming and how the foam shall be applied. Use the sanded face against the foam. Again, make sure that the clamps sit directly on the spacers. After 24 hours, remove the hand clamps and the spacers. Cut the excess foam that has

expanded from the interior of the assembly so that it is flush with the plywood edges. Measure the initial, inner plywood to plywood board dimensions. After taking the measurements, store the assemblies in the required test climates.

The test climates are:

(40 ± 2) °C / (90 ± 5) % relative humidity

(30 ± 2) °C / (30 ± 5) % relative humidity

#### B.11.1.4 Evaluation

At day 7 and 14, the specimens shall be removed from the respective test chambers and then stored for a minimum of 2 hours at standard conditions in accordance with EN 13238, procedure for conditioning to constant mass. At the four corners, the distance between the boards is measured as near as possible to the interior foam surface (distance “c” in Figure B.2). Alternatively, if there are any surface irregularities, the distance can be measured at the exact middle of the specimen where the two spacers were placed (Figure B.3). After the first measurement, place the specimens back in the proper chamber.

#### B.11.1.5 Dimensional stability calculation

The dimensional stability, d, is calculated as the percentage change in the assembly dimensions:

$$d = \left( \frac{b}{c} \times 100 \right) - 100 (\%)$$

b (mm) = Measured width of the gap after storage in the test chamber

c (mm) = Starting value before storage

The dimensional stability d of one specimen is given by the mean value of the four or two measuring points. The mean value of each assembly and the mean value of all assemblies as well as the standard deviation are recorded.

The overall mean value together with its standard deviation shall be reported.

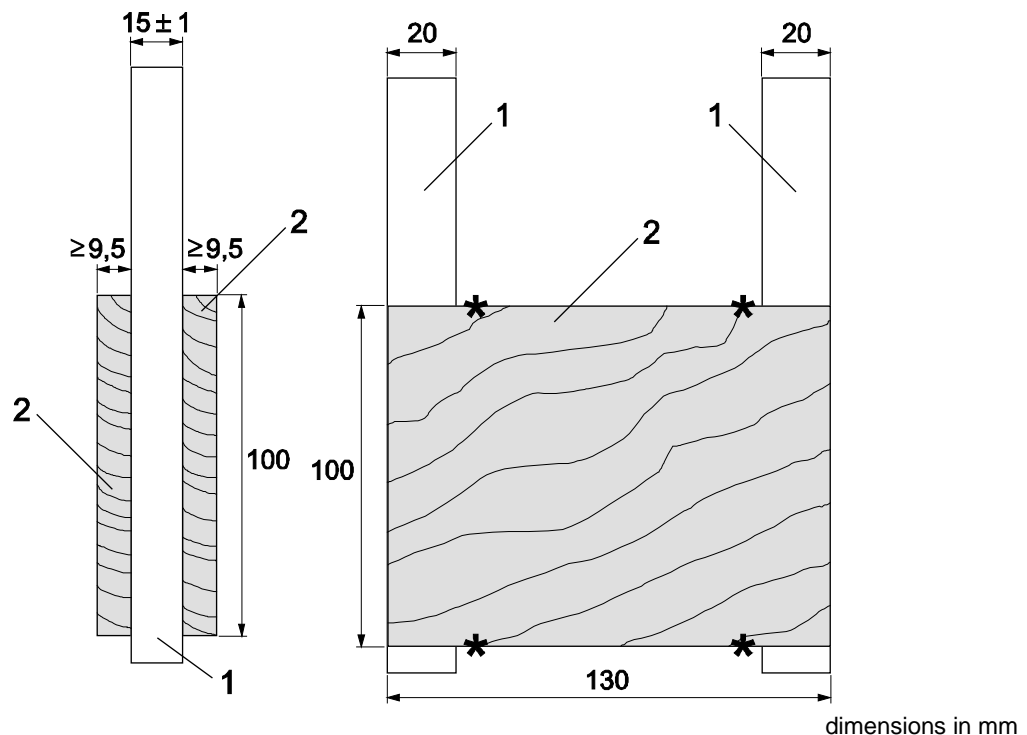

#### Key

1 Spacer

2 Plywood

\* Locations for determination of thickness after exposure

**Figure B.1 – Specimens for determination of dimensional stability – side view**



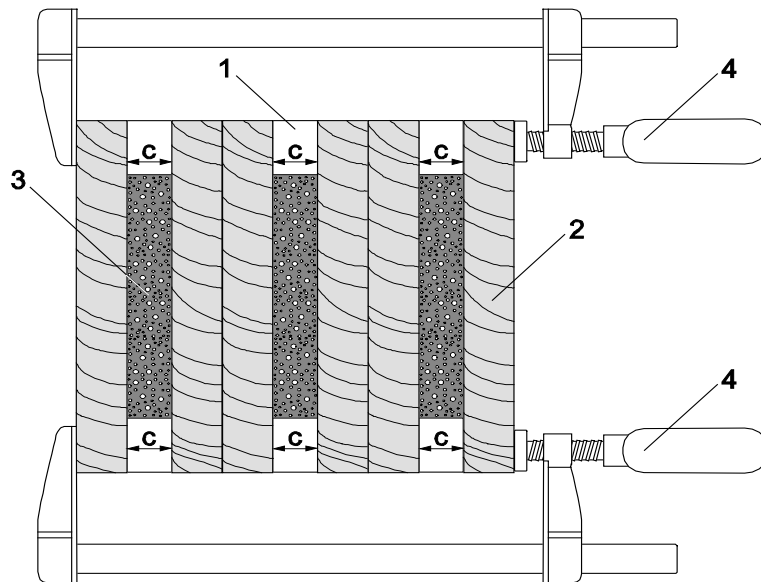

dimensions in mm

**Key**

- 1 Spacer
- 2 Plywood
- 3 Foam
- 4 Clamps
- c Dimension of the specimens determined after exposure

**Figure B.2 – Specimens for determination of dimensional stability – top view**

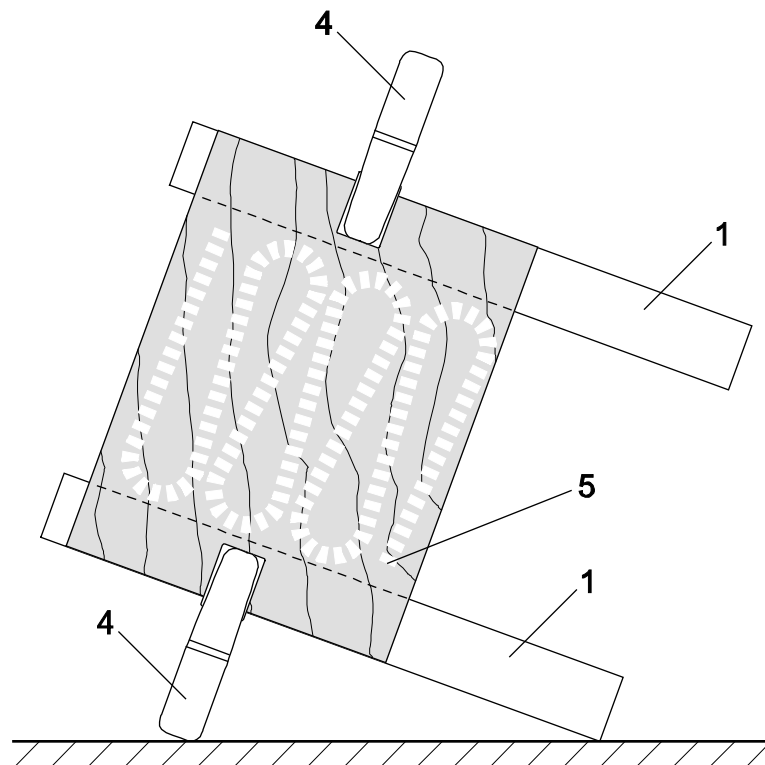

dimensions in mm

**Key**

- 1 Spacer
- 4 Clamps
- 5 Starting point for foaming

**Figure B.3 – Set-up for foaming**

## B.11.2 Linear expansion on setting (gypsum based mortar)

### B.11.2.1 General

The linear expansion on setting shall be determined in continuous damp air storage by means of a simple extensometer described in B.11.2.2 with the neat plaster gauged to a standard final coat consistence. The plaster shall be stabilised before test by the method described in B.11.2.5.

### B.11.2.2 Extensometer

The extensometer has an open V-shaped cradle closed at one end by a fixed plate and at the other end by a movable partition carried on the stem of an ordinary watch pattern dial micrometer gauge reading to 1/100 mm (see Fig. B.4). The cradle is of brass or bronze 100 mm long, about 60 mm wide and 25 mm deep with a rounded bottom. The take-up or returning spring shall be light and the movement free.

To prevent the plaster sticking to the sides of the cradle, grease before use and line internally with thin non-absorbent paper having a glazed surface. Renew the paper lining for each test. Fill the gauged plaster into the cradle while the movable plate is held against the end, and strike off smooth and level with the top of the cradle.



Figure B.4 – Extensometer

### B.11.2.3 Zero adjustment

Move the movable partition very slightly forward clear of the end to eliminate backlash. Bring the plaster solid against the movable partition. Make any necessary zero adjustment on the dial.

### B.11.2.4 Gauging and measurement

A convenient quantity of plaster to use is about 200 g. Gauge this with water in the manner and to the standard final coat consistence described in B.11.2.6. Fill the gauged plaster immediately into the cradle of the extensometer and adjust the zero point as described in B.11.2.3. Place the extensometer in the damp closet and note the zero reading. Leave it undisturbed for 24 hours and then take the final reading. Calculate the percentage linear expansion

$$\text{Percent linear expansion} = \frac{\text{difference in dial readings in } 1/100 \text{ mm}}{100}$$

### B.11.2.5 Method of stabilizing plasters

Expose the plaster for 3-4 days in a layer not more than 12 mm in thickness to an atmosphere of  $65 \pm 3\%$  relative humidity at a temperature of  $20 \pm 5^\circ\text{C}$  with vigorous air circulation over the specimen throughout this period.

If a conditioned room is not available, maintain the humidity by means of a saturated solution of ammonium nitrate contained together with the solid salt in a wide dish, and placed in a tightly-closed cabinet. Keep the air in the cabinet moving over both solution and plaster.

### B.11.2.6 Standard consistence

The standard final coat consistence shall be determined by means of a dropping ball penetrometer precisely as described below.

Fill a ring mould made from a rigid material, 100 mm internal diameter, 25 mm internal depth with the paste under test. Rest the mould on a non-porous plate, fill it by using a flexible palette-knife in about ten increments in such a manner as to eliminate voids or air-bubbles. Smooth off the surface of the paste level with the top of the mould.

Drop a 25 mm diameter methylmethacrylate ball of a mass of  $9,8 \pm 1$  g from rest from a height of 250 mm measured from the bottom of the ball to the surface of the paste, so that it falls approximately into the centre of the ring. Record the penetration as the distance from the lowest point of the ball to the level of the original surface of the material.

Measure the depth of penetration by a suitable method.

The paste is of the correct consistence, when the ball penetrates 15-16 mm.

When early stiffening occurs, 0,1 g of sodium citrate may be added to the gauging water for the determination of consistence.

## **B.12 Visual examination**

The appearance of the product shall be examined for changes in e.g. colour, texture, shape or for the appearance of cracks and fissures. If changes in appearance are not reflected in the results of the examination of the other properties given in clause 2.4.1.3.1.1.3.2, possible consequences of the changes in appearance, on durability, shall be assessed on a case by case basis.

## **B.13 Methods for determination of movement capability (mc)**

### **B.13.1 General**

This section only applies to joint seals where the claimed movement capability is  $\geq 7.5\%$ .

A cycling test shall be used to determine movement capability for all product types except for sealants / mastics. For these the method given in ISO 11600 is used.

The principle of the test is to simulate the joint seal with a specimen of minimum 30 cm length and the maximum intended nominal width and the related depth. The specimen shall be subjected to a cycling of minimum 500 cycles at a frequency of 0,1 cpm and an amplitude corresponding to the intended movement capability. The movement may be lateral or shear.

The temperature of the test assembly shall be maintained within a range of  $(23 \pm 5)$  °C.

After cycling, the test construction shall be allowed to stabilise for 1 hour, without disturbance before assessment of the specimen. Failure criteria are cohesion or adhesion failure or failure at the fixings for AF, MF and SA type of seals and displacement of the seal for FF type seals. FF type seals are to be cycled in a horizontal position. After the stabilisation period following the cycling the specimen is turned upright to check whether the seal remains in position.

### **B.13.2 Adhesion fixed products (AF)**

The maximum nominal joint width intended shall be used for the test. The product shall be installed as in practice regarding depth of the seal in relation to the chosen width (gap-mounted) or overlap (surface-mounted), type and amount of adhesive and preparation of the surface of the joint face (e.g. use of primer).

### **B.13.3 Friction fixed products (FF)**

The maximum nominal width intended shall be used for the test. The product shall be installed as in practice regarding depth of the seal in relation to the chosen width and compression.

### **B.13.4 Mechanically fixed products (MF)**

The maximum nominal width intended shall be used for the test. The product shall be installed as in practice regarding depth of the seal in relation to the chosen width (gap-mounted) or overlap (surface-mounted), type, location and minimum number / distance of fixings. If necessary the specimen may be enlarged to accommodate the fixings.

### **B.13.5 Self-adherent products (SA)**

#### **B.13.5.1 Sealants / mastics and putties**

The following tests shall be conducted to get a classification according to ISO 11600:

For all types:

- Elastic recovery according to ISO 7389 (conditioning method B)
- Loss of volume according to ISO 10563
- Flow of sealants according to ISO 7390

for materials with expected mc $\geq$ 12.5 % (elastic materials):	for materials with expected mc of < 12.5 % (plastic materials):
<ul style="list-style-type: none"> <li>Tensile properties at maintained extension according to ISO 8340 using conditioning method B</li> </ul>	<ul style="list-style-type: none"> <li>Tensile properties according to ISO 8339 using conditioning method B</li> </ul>
<ul style="list-style-type: none"> <li>Adhesion/cohesion at variable temperature according to ISO 9047 using conditioning method B.</li> </ul>	<ul style="list-style-type: none"> <li>Adhesion/cohesion at constant temperature according to ISO 9046 using conditioning method B</li> </ul>

#### B.13.5.2 Others

The maximum nominal width intended shall be used for the test. The product shall be installed as in practice regarding depth of the seal in relation to the chosen width (gap-mounted) or overlap (surface-mounted) and preparation of the surface of the joint face (e.g. use of primer).

#### B.14 Compression set

The test is carried out with the same type and size of specimen as the cycling test for determination of movement capability except that the specimen is not cycled but compressed with a static load corresponding to the intended movement capability. After 24 hours under compression the specimen is release to the nominal width. The same assessment procedure and failure criteria as for the cycling test are used.

#### B.15 Determination of a deterioration rate

The test specimen shall have a minimum length of 200 mm, a minimum width and depth of 100 mm. Where any surface of the specimen was produced by cutting it shall be cleaned from loose particles. The overall surface area is determined, expressed in m<sup>2</sup>. Afterwards the specimen is conditioned according to EN 13238 to constant mass. The final mass, determined to the nearest 0,01 g is recorded.

After exposure to the test climate the specimen is cleaned by removing any loose particles and weighed to the nearest 0.01 g. The "deterioration rate" is calculated

$$\text{"corrosion rate"} = \frac{\text{Mass before (g)} - \text{mass after (g)}}{\text{surface (m}^2\text{)} \cdot \text{exposure duration (h)} \cdot 8760} \quad (\text{g/m}^2 \cdot \text{year})$$

## ANNEX C

### Water Permeability Tests

#### C.1 Test to simulate external use (rain)

Test according to EN 12155 using the classes from EN 12154 as use categories, subject to the following: A sample representative of the fire stopping or fire sealing product shall be used to prepare a linear joint seal following the installation instructions of the manufacturer. If a splice is required to construct longer seals a single splice shall be included in the test specimen. The length of the joint seal shall be minimum 1 m. Water tightness is always relevant for the seal and not only for the seal material, so the interface shall be tested, i.e. the supporting constructions claimed shall be represented (e.g. steel, dense concrete, aerated concrete). This representation may be achieved by using a facing material on a structure of another material.

#### C.2 Test to simulate internal use (water pressure test)

##### C.2.1 Test sample

A sample representative of the fire stopping or fire sealing product shall be used to prepare a linear joint seal following the installation instructions of the manufacturer. If a splice is required to construct longer seals a single splice shall be included in the test specimen.

##### C.2.2 Conditioning

The test specimen shall be conditioned in accordance with EN 13238 using the procedure for conditioning to constant mass.

##### C.2.3 Test apparatus

The water leakage test apparatus shall consist of a container open both ends the base of which shall form a watertight seal against the test specimen. The container shall accommodate a specimen of minimum 1 m length and the intended width and sufficient part of the supporting construction.

##### C.2.4 Test procedure

The water leakage test apparatus shall be sealed to the test specimen using non-hardening sealants, pressure-sensitive tape or rubber gaskets with clamping devices.

Water, with a permanent dye, shall be placed in the water leakage test chamber. The water shall cover the penetration seal to a depth corresponding to the required pressure<sup>23</sup>, which shall be maintained during the test. The temperature of the test assembly shall be maintained within a range of  $(23 \pm 5)$  °C.

A white indicating medium shall be placed immediately below the test specimen.

The test shall be continued until leakage is observed or a maximum of 72 hours.

##### C.2.5 Evaluation of the test results

The leakage of water through the penetration seal shall be noted by the presence of water or dye on the indicating media or on the underside of the test assembly.

##### C.2.6 Recorded test data

The result is given as “water tight to x mm of water pressure” or “water tight to x Pa”.

The test report shall include the following:

- a) A description of the assembly and materials of the linear joint seal under test, including drawings depicting geometry, exact size (length, width, and thickness), and location of the seal within the test assembly.
- b) The relative humidity of the test assembly and linear joint seal materials, if applicable.

---

<sup>23</sup> Requirement from a regulation or comparable specification

## ANNEX D

Flow Diagram For the selection of the relevant conditions of the resistance to fire test

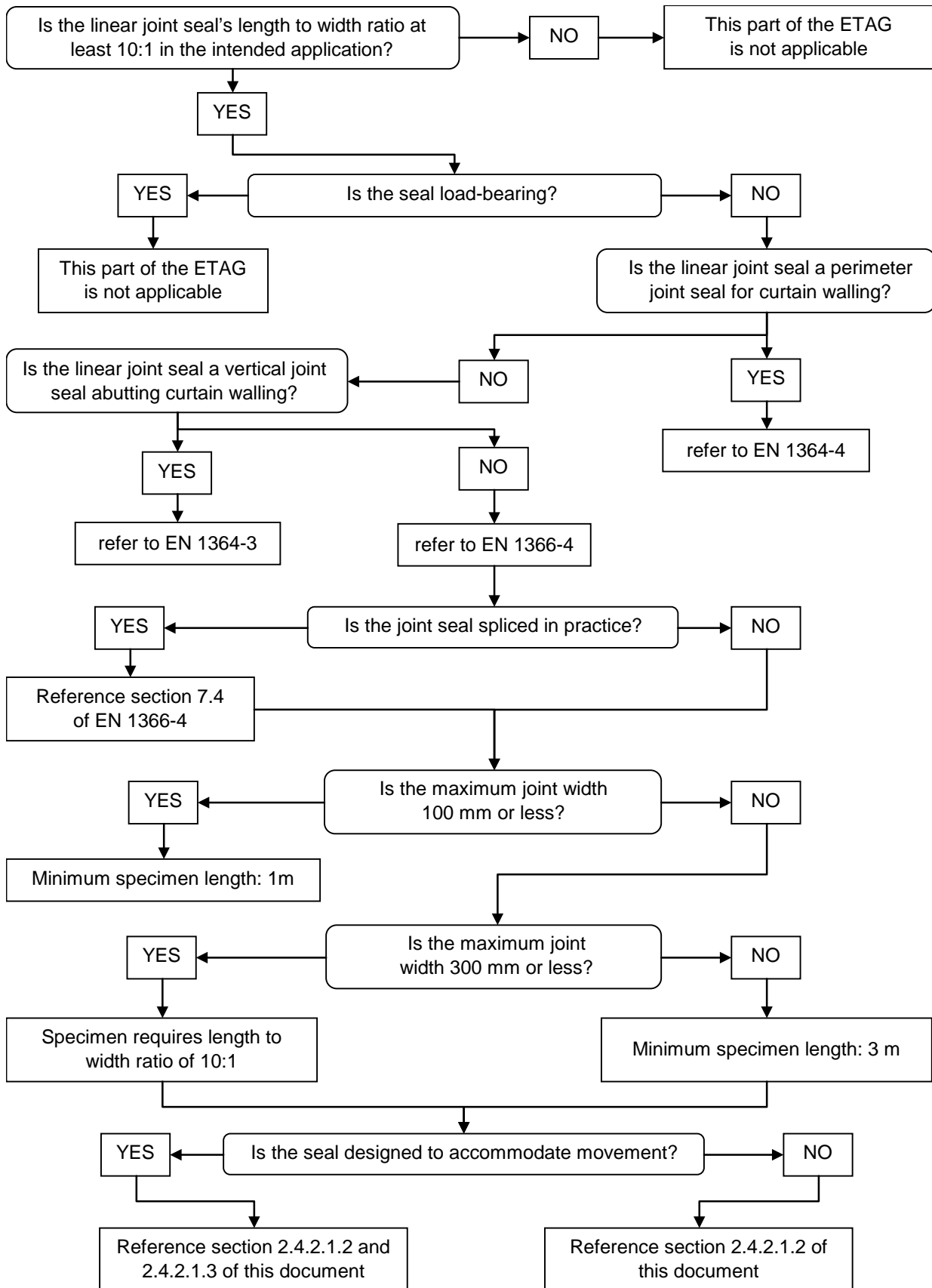

# ANNEX E

## Details for Resistance to Fire Test Conditions for Movement Joint Seals

### E.1 Case a) according to 2.4.2.1.3: Nominal width + elongation

The product shall be installed at the nominal width selected according to 2.4.2.1.2 with superimposed lateral elongation of 100% of the movement capability given by the manufacturer (see Figure E.1).

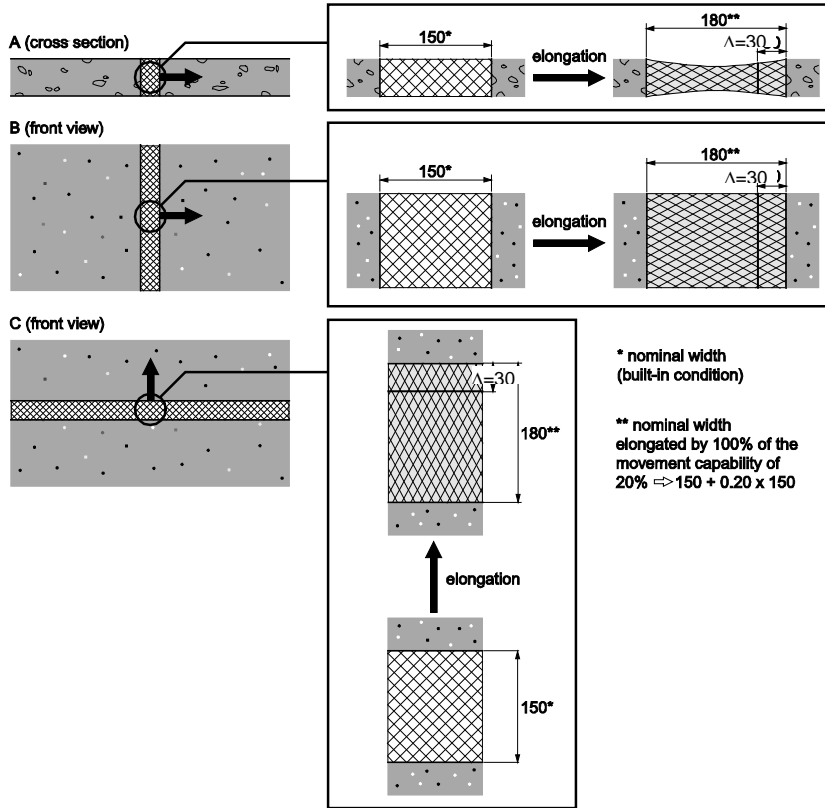

#### Key



Floor – section



Wall – front view



Joint seal – before elongation



Joint seal – after elongation



Direction of elongation

A Joint seal in a floor

B Vertical joint seal in a wall

C Horizontal joint seal in a wall

**Figure E.1 – Test condition with lateral elongation at the maximum of the nominal width**

**Note 10:** The figure shows only joints with 20% elongation; smaller lateral elongations would be used for joints with smaller specified elongations.

## E.2 Case b) according to 2.4.2.1.3: Nominal width + shear

The product shall be installed at the nominal width with superimposed shear so that  $\Delta$  equals 100% of the movement capability given by the manufacturer (see Figure E.2) <sup>24</sup>. The "shear extension"  $x$  can be calculated from the formula given below.

$$x = w \sqrt{mc/100 (2 + mc/100)}$$

where

$x$  = "shear extension" (vertical displacement of one joint edge, see Figure E.2)

$w$  = nominal joint width (millimetres)

$mc$  = movement capability (%) as requested by the applicant and determined according to B.13

Example with  $w = 150$  mm and  $mc = 20\%$ :

$$x = 150 \sqrt{20/100 (2 + 20/100)} = 150 \sqrt{0,2 \times 2,2} = 150 \times 0,663 = 99,5 \text{ mm}$$

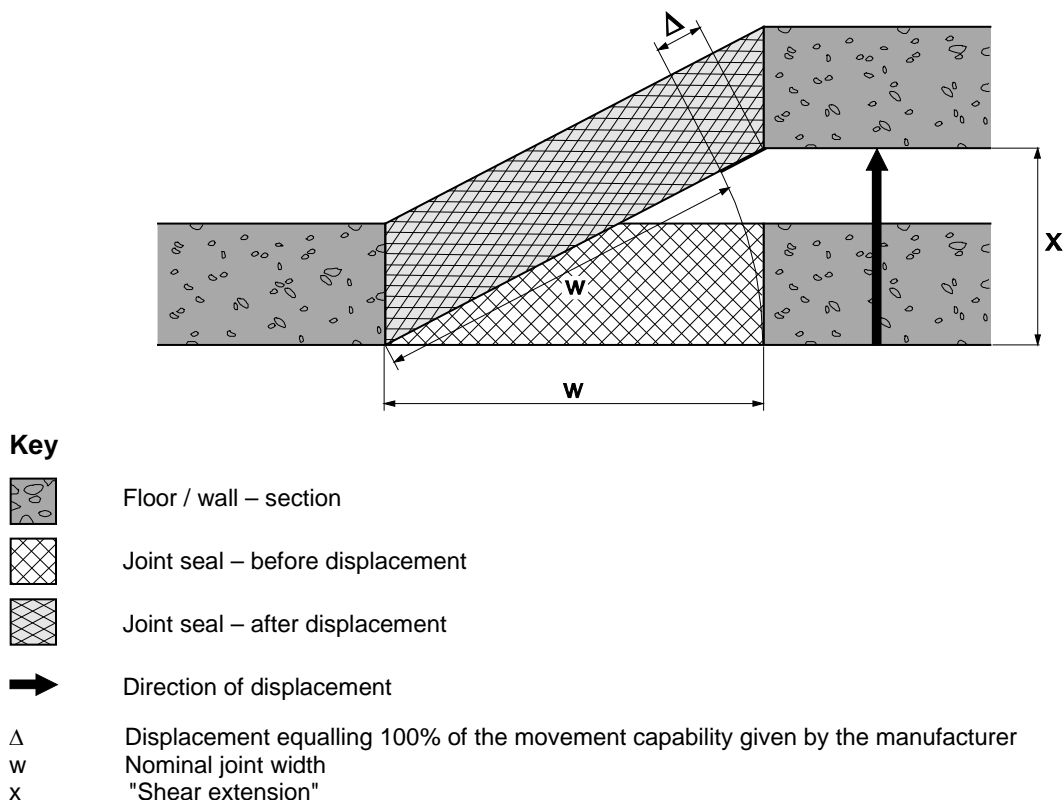

Figure E.2: Test condition with superimposed shear at the maximum of the nominal width

## E.3 Combination of elongation and shear

Where a combination of elongation and shear is desired to be used the specimen shall be treated according to Figure E.3.  $\Delta$  shall equal to 100% of the movement capability given by the manufacturer. The "shear extension" portion  $x_S$  can be calculated using the formula given below for any chosen value of the elongation portion  $x_E$ .

$$x_S = \sqrt{w^2 mc/100 (2 + mc/100) - 2x_E (w + x_E)}$$

where

$x_S$  = "Shear extension" portion of the displacement (vertical displacement of one joint edge, see Figure E.3)

<sup>24</sup> This method is normally not suitable for testing strip type seals



$x_E$  = Elongation portion of the displacement (horizontal displacement of one joint edge, see Figure E.3)

$w$  = Nominal joint width

$mc$  = Movement capability (%) as requested by the applicant and determined according to B.13

Figure E.4 shows the dependence of  $x_S$  on  $x_E$  for a joint width of 100 mm for several movement capability values for a particular material as an example.

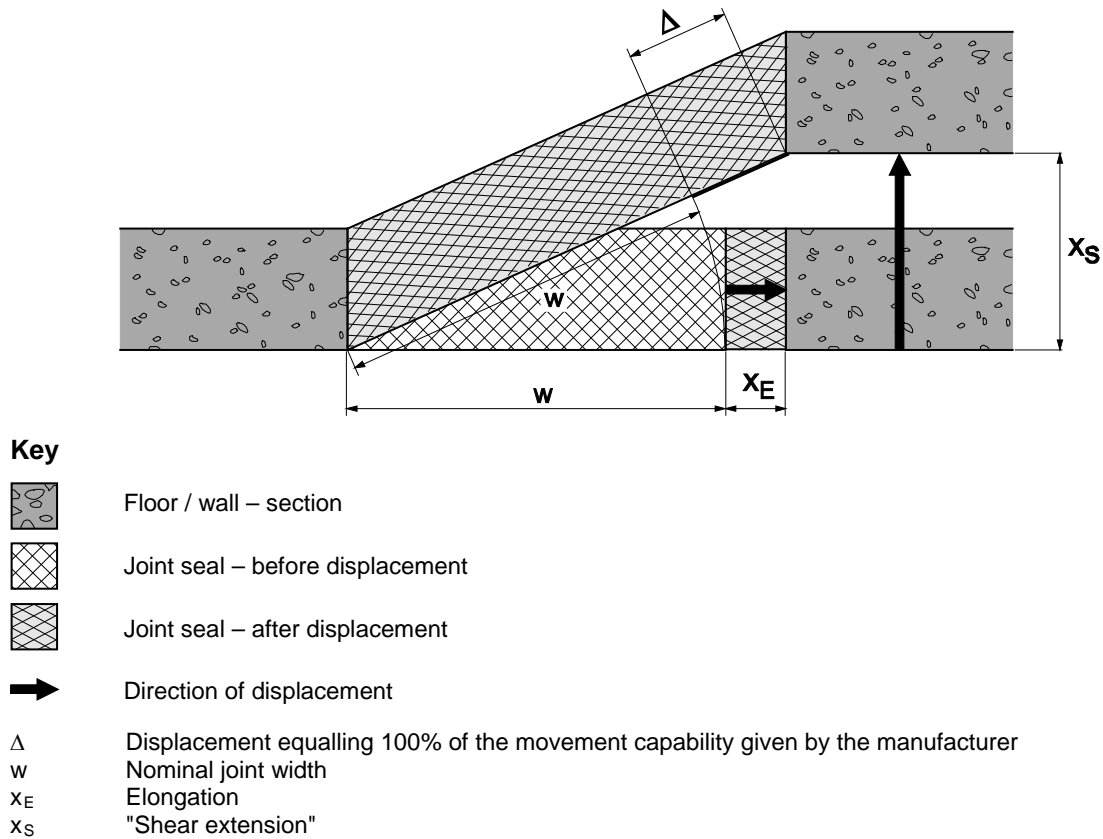

**Figure E.3: Test condition with a combination of lateral elongation and shear at the maximum of the nominal width**

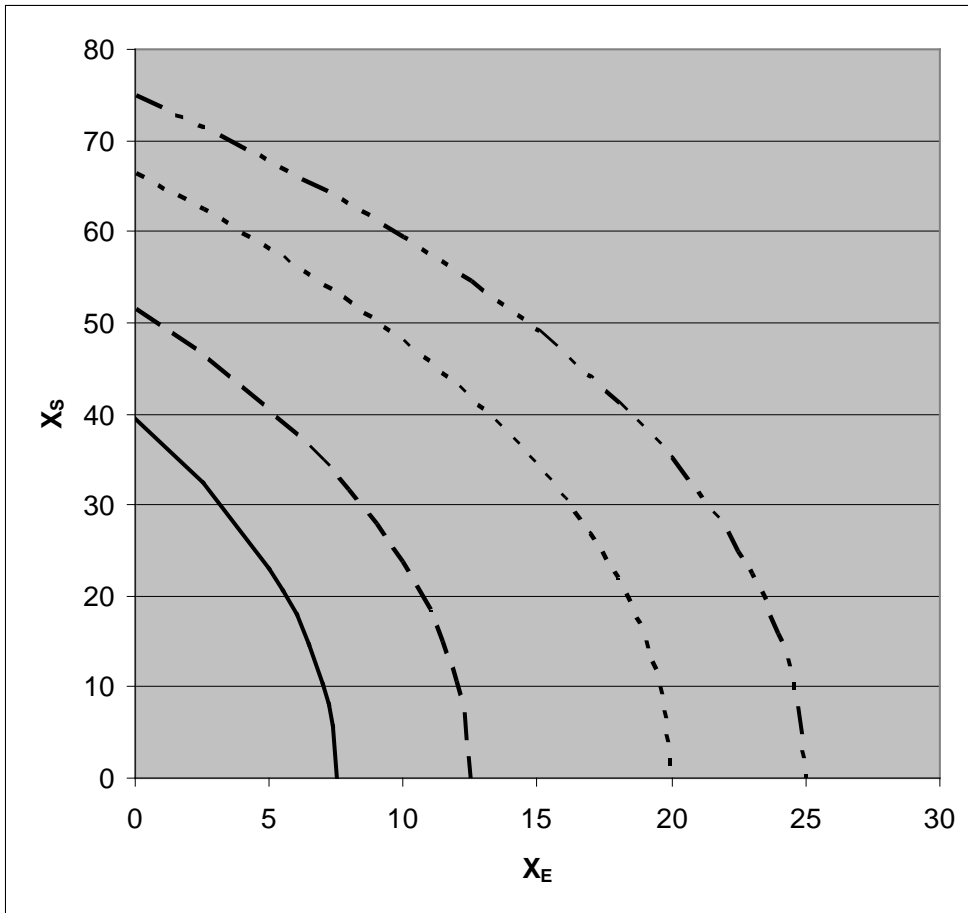

**Key**

- Movement capability = 7,5 %
- - - Movement capability = 12,5 %
- - - · Movement capability = 20 %
- · · - Movement capability = 25 %

**Figure E.4 – Example for the dependence of  $x_s$  on  $x_E$  for several movement capability values for a particular material of a joint width of 100 mm**

## ANNEX F

### Rules for determining the field of application of resistance to fire

#### F.1 Supporting Construction

A rating obtained on a specific supporting construction applies only to that particular type of separating element. When a standard supporting construction described either in the relevant test standard or in this document is used, the range of application may be extended.

##### F.1.1 Separating elements — Concrete or masonry

See sentence in EN 1366-3 (equal or greater thickness and density)

##### F.1.2 Separating elements – Flexible wall constructions

Test results obtained with the standard flexible wall constructions according to 2.4.2.1.4 cover all flexible wall constructions of the same fire resistance classification provided the following:

- the construction is classified in accordance with EN 13501-2,
- the construction has an overall thickness not less than the standard configuration used in the test

Test results obtained with the flexible standard wall constructions according to 2.4.2.1.4 also apply to flexible constructions with timber studs (breadth/depth  $\geq 50 \text{ mm} \times 75 \text{ mm}$ ) constructed in the same manner with at least the same number of layers, provided that no part of the linear joint seal is closer than 100 mm to a stud, that the cavity is closed between the linear joint seal and the stud, and that 100 mm of insulation is provided within the cavity between the linear joint seal and the stud.

A specific edge closure is considered as being part of the linear joint seal. Results from such tests are only valid provided the same edge closure is used in practice.

The standard flexible wall construction does not cover sandwich panel constructions. Linear joints in such constructions shall be tested on a case by case basis.

Test results obtained with flexible wall constructions may be applied to concrete or masonry elements of a thickness equal to or greater than that of the element used in the tests.

#### F.2 Seal depth

Variation	Effect	Comment
Increase in seal depth	= or +	Acceptable
Decrease in seal depth	-	Not acceptable

#### F.3 Backing material

This section relates to the change of material used to back a seal or sealant as part of a linear joint seal

Backing material	Effect	Comment
Polyethylene / Polyurethane rods	= or +	May be replaced by mineral wool
Glass wool	= or +	May be replaced by stone wool or ceramic wool
Stone wool	= or +	May be replaced by ceramic wool
Ceramic wool (including ceramic alternatives)	=	May only be replaced by alternative material of equivalent material properties, i.e. density, thermal conductivity, melting point, shrinkage, reaction to fire classification - for example alkaline earth silicate fibres
Increase in backing material depth	+	Acceptable for class A1 and A2 materials
Decrease in backing material depth	-	Not acceptable

**Note F1** The above comments relate to materials of an equivalent or greater depth and/or density.

## F.4 Configuration

### F.4.1 General

For foam seals (foamed in-situ and pre-formed), compressible strips (including composite, laminated, impregnated) and sealants the distance of the seal from the exposed face in concrete/masonry wall/floor may be increased from that tested.

For mortar seals and mineral wool based seals a change of position of the seal within the thickness of separating element is acceptable, provided the overall depth of the seal is equal to or greater than that tested.

For mineral wool based seals a seal protruding outside the joint is acceptable, where the depth of seal within the joint is equal or greater than that tested.

### F.4.2 Distance between splices

An increase in the distance between splices is acceptable. A reduction in the distance between splices is not acceptable. Figure F.2.1 shows an example for a mineral based seal

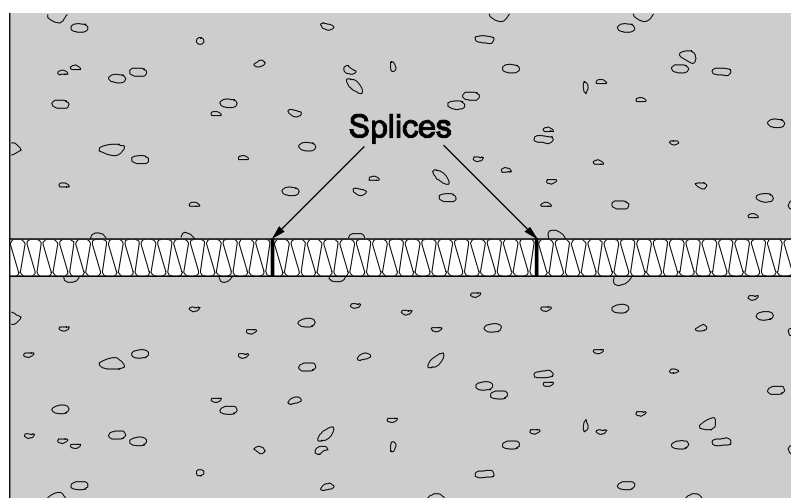

Figure F.2.1 – Mineral wool – Distance between splices

### F.4.3 Material thickness

For fabrics, elastomeric strips and membrane forming coatings the material thickness may be increased but not reduced.

### F.4.4 Material density

For mineral wool based seals tested with a nominal density between 50 kg/m<sup>3</sup> and 200 kg/m<sup>3</sup>, an increase in density up to a maximum of 200 kg/m<sup>3</sup> is acceptable.

A reduction of density is not acceptable without test evidence to support the change.

### F.4.5 Surface coatings / coverings/ facings

The subsequent application of a surface covering (facing) to mineral wool based seals is acceptable, providing the seal depth is not reduced. The thickness of the surface covering shall not be considered as part of the effective seal depth.

The removal of a surface covering which formed an intrinsic part of the seal system as tested is not acceptable.

### **Cover page of the ETA**

*according to Document 5.1 (new ETA), Document 5.2 (modified ETA) or Document 5.3 (ETA with extended period of validity), as relevant.*

### **Page 2 of the ETA**

*with headline Page 2 of ETA-xx/xxxx, issued on dd.mm.yyyy[, validity extended on dd.mm.yyyy]*

## **I LEGAL BASES AND GENERAL CONDITIONS**

- 1 This European Technical Approval is issued by ...*(name of Approval Body)* in accordance with:
  - Council Directive 89/106/EEC of 21 December 1988 on the approximation of laws, regulations and administrative provisions of Member States relating to construction products<sup>25</sup> modified by Council Directive 93/68/EEC<sup>26</sup> and Regulation (EC) N° 1882/2003 of the European Parliament and of the Council<sup>27</sup>;
  - ...*(indicate respective national law transposing the CPD; only if the national law of the Member State of the issuing Approval Body so requires)*;
  - Common Procedural Rules for Requesting, Preparing and the Granting of European Technical Approvals set out in the Annex to Commission Decision 94/23/EC<sup>28</sup>;
  - Guideline ...*(indicate title and number of ETA Guideline on the basis of which the ETA is granted, unless ETA is issued without an ETA Guideline in accordance with point 3.2 of the Common Procedural Rules, pursuant to Article 9(2) of the CPD)*.
- 2 The ...*(name of issuing Approval Body)* is authorized to check whether the provisions of this European Technical Approval are met. Checking may take place in the manufacturing plant(s). Nevertheless, the responsibility for the conformity of the products to the European Technical Approval and for their fitness for the intended use remains with the holder of the European Technical Approval.
- 3 This European Technical Approval is not to be transferred to manufacturers or agents of manufacturers other than those indicated on page 1, or manufacturing plants other than those /indicated on page 1/ laid down in the context/ of this European Technical Approval (*delete as appropriate*).
- 4 This European Technical Approval may be withdrawn by ...*(name of issuing Approval Body)*, in particular pursuant to information by the Commission according to Article 5(1) of Council Directive 89/106/EEC.
- 5 Reproduction of this European Technical Approval including transmission by electronic means shall be in full. However, partial reproduction can be made with the written consent of ...*(name of issuing Approval Body)*. In this case partial reproduction has to be designated as such. Texts and drawings of advertising brochures shall not contradict or misuse the European Technical Approval.
- 6 The European Technical Approval is issued by the Approval Body in its official language(s). This (These) version(s) corresponds (correspond) fully to the version circulated in EOTA. Translations into other languages have to be designated as such.

---

<sup>25</sup> Official Journal of the European Communities N° L 40, 11.2.1989, p. 12

<sup>26</sup> Official Journal of the European Communities N° L 220, 30.8.1993, p. 1

<sup>27</sup> Official Journal of the European Union N° L 284, 31.10.2003, p.1

<sup>28</sup> Official Journal of the European Communities N° L 17, 20.1.1994, p. 34

## Page 3 and following pages of the ETA

with headline Page ... of ETA-xx/xxxx, issued on dd.mm.yyyy[, validity extended on dd.mm.yyyy]

### II SPECIFIC CONDITIONS OF THE EUROPEAN TECHNICAL APPROVAL

#### 1 Definition of product(s) and intended use

##### 1.1 Definition of the construction product

..... (Specific text)

##### 1.2 Intended use

..... (Specific text)

The provisions made in this European technical approval are based on an assumed working life of the ...(*product*) of ... years. The indications given on the working life cannot be interpreted as a guarantee given by the producer, but are to be regarded only as a means for choosing the right products in relation to the expected economically reasonable working life of the works.

#### 2 Characteristics of product(s) and methods of verification

..... (Specific text)

*The ETA shall clearly specify the tested assembly, identifying the components used (e.g. supporting construction, mechanical fasteners, etc.), the dimension or range of sizes, the configuration etc.*

*The field of application shall be specified, taking account of all relevant parameters, e.g. dimension of the seal, the use conditions in terms of environmental conditions (e.g. dry indoor use), the method of preparation of the supporting construction before installation of the linear joint seal.*

**The following statements may be considered for inclusion in the ETA:**

##### **General:**

"Other parts or supporting constructions must not penetrate the seal."

"Provisions shall be taken such that floor joint seals cannot be stepped on or are not subjected to forces higher than the limit taken from the impact tests, e.g. by covering with a wire mesh."

##### 2.[ ] Emission of dangerous substances or radiation

..... (Specific text)

**Note:** In addition to the specific clauses relating to dangerous substances contained in this European Technical Approval, there may be other requirements applicable to the products falling within its scope (e.g. transposed European legislation and national laws, regulations and administrative provisions). In order to meet the provisions of the Construction Products Directive, these requirements need also to be complied with, when and where they apply.

#### 3 Evaluation and attestation of conformity and CE marking

##### 3.1 System of attestation of conformity

According to the decision 1999/454/EC of the European Commission<sup>29</sup> the system 1 of attestation of conformity applies.

This system of attestation of conformity is defined as follows:

System 1: Certification of the conformity of the product by a approved certification body on the basis of:

(a) Tasks for the manufacturer:

- (1) factory production control;
- (2) further testing of samples taken at the factory by the manufacturer in accordance with a prescribed test plan;

(b) Tasks for the notified body:

- (3) initial type-testing of the product;
- (4) initial inspection of factory and of factory production control;
- (5) continuous surveillance, assessment and approval of factory production control.

##### 3.2 Responsibilities

###### 3.2.1 Tasks of the manufacturer

###### 3.2.1.1 Factory production control

The manufacturer shall exercise permanent internal control of production. All the elements, requirements and provisions adopted by the manufacturer shall be documented in a systematic manner in the form of

---

<sup>29</sup> Official Journal of the European Communities L 178 of 14/07/1999

written policies and procedures, including records of results performed. This production control system shall insure that the product is in conformity with this European technical approval.

The manufacturer may only use initial / raw / constituent materials (*as relevant*) stated in the technical documentation of this European technical approval.

The factory production control shall be in accordance with the "Control Plan of ...(*date*) relating to the European technical approval ETA -...(*number*) issued on ...(*date*)" which is part of the technical documentation of this European technical approval. The "Control Plan" is laid down in the context of the factory production control system operated by the manufacturer and deposited at the ...(*name of the Approval Body*).<sup>30</sup>

The results of factory production control shall be recorded and evaluated in accordance with the provisions of the "Control Plan".

### 3.2.1.2 Other tasks of manufacturer

..... (*Specific text, if relevant*)

#### **Additional information**

The manufacturer shall provide a technical data sheet and an installation instruction with the following minimum information:

*Technical data sheet:*

- Field of application:
  - Building elements for which the linear joint seal is suitable, type and properties of the building elements like minimum thickness, density, and - in case of lightweight constructions - the construction requirements.
  - Limits in size, minimum thickness etc. of the linear joint seal
- Construction of the linear joint seal including the necessary components and additional products (e.g. backfilling material) with clear indication whether they are generic or specific.

*Installation instruction:*

- Steps to be followed
- Procedure in case of retrofitting.

The manufacturer shall, on the basis of a contract, involve a body (bodies) which is (are) approved for the tasks referred to in section 3.1 in the field of ...(*product*) in order to undertake the actions laid down in section 3.3. For this purpose, the "control plan" referred to in sections 3.2.1.1 and 3.2.2 shall be handed over by the manufacturer to the notified body or bodies involved.

The manufacturer shall make a declaration of conformity, stating that the construction product is in conformity with the provisions of the European technical approval ETA ...(*number*) issued on ...(*date*).

### 3.2.2 Tasks of notified bodies

The notified body (bodies) shall perform the

- initial type-testing of the product,
- initial inspection of factory and of factory production control,
- continuous surveillance, assessment and approval of factory production control,

in accordance with the provisions laid down in the "Control Plan of ...(*date*) relating to the European technical approval ETA -...(*number*) issued on ...(*date*)".

The notified body (bodies) shall retain the essential points of its (their) actions referred to above and state the results obtained and conclusions drawn in (a) written report (reports).

The approved certification body involved by the manufacturer shall issue an EC certificate of conformity of the product stating the conformity with the provisions of this European technical approval.

In cases where the provisions of the European technical approval and its "Control Plan" are no longer fulfilled the certification body shall withdraw the certificate of conformity and inform the ...(*name of Approval Body*) without delay.

## **3.3 CE marking**

The CE marking shall be affixed on the ...(*product itself - indicate where on the product, if necessary; or the label attached to it; packaging; accompanying commercial document*). The marking „CE“ shall be followed by the identification number of the approved certification body and be accompanied by the following additional information:

- the name and address of the producer (legal entity responsible for the manufacturer),
- the last two digits of the year in which the CE marking was affixed,
- the number of the EC certificate of conformity for the product,
- the number of the European technical approval,
- the number of the Guideline for European technical approval
- ... (performances, use categories, etc. of the product as listed in accordance with the provisions of the ETAG),

Example(s) of CE marking and accompanying information for ...(*product*):

 1234	<b>"CE"-marking</b> Identification number of approved certification body
Any company Street 1, City, Country 04 1234-CPD-0321	Name and address of the producer (legal entity responsible for the manufacturer)  Two last digits of year of affixing the CE marking Number of EC certificate of conformity
ETA-07/XYZZ ETAG 026 part 3  Linear joint seal ETA-11/XYZZ	Number of European technical approval Number of Guideline for the European technical approval  Name See the ETA for relevant characteristics

..... (If the content of the CE marking and accompanying information is not the same for all products covered in the ETA, give further examples of CE marking and accompanying information for each of the possible cases in accordance with the provisions of the ETAG)

#### **4 Assumptions under which the fitness of the product(s) for the intended use was favourably assessed**

##### **4.1 Manufacturing**

..... (Specific text, as far as relevant)

The European technical approval is issued for the product on the basis of agreed data/information, deposited with the ...(*Approval Body name*), which identifies the product that has been assessed and judged. Changes to the product or production process, which could result in this deposited data/information being incorrect, should be notified to the ...(*Approval Body name*) before the changes are introduced. The ...(*Approval Body name*) will decide whether or not such changes affect the ETA and consequently the validity of the CE marking on the basis of the ETA and if so whether further assessment or alterations to the ETA, shall be necessary.

##### **4.2 Installation**

..... (Specific text, as far as relevant)

#### **5 Indications to the manufacturer**

##### **5.1 Packaging, transport and storage**

..... (Specific text, as far as relevant)

##### **5.2 Use, maintenance, repair**

..... (Specific text, as far as relevant)

#### **ANNEX 1 - DESCRIPTION OF PRODUCT(S)**

..... (Specific text and/or drawings, as far as relevant)

..... (Give further annexes as far as necessary)