



European Technical Assessment

ETA 19/0664
of 09.12.2019



General part

Technical Assessment Body issuing the ETA: ITeC

ITeC has been designated according to Article 29 of Regulation (EU) No 305/2011 and is member of EOTA (European Organisation for Technical Assessment).

Trade name of the construction product

AF SLEEVE

Product family to which the construction product belongs

Fire stopping and fire sealing products.
Penetration seals.

Manufacturer

AF SYSTEMS SRL
Via Edward Jenner 41-43
IT-26837 Mulazzano
Italy

Manufacturing plant(s)

According to Annex N kept by ITeC.

This European Technical Assessment contains

11 pages including 2 Annexes which form an integral part of this assessment

and

Annex N, which contains confidential information and is not included in the European Technical Assessment when that assessment is publicly available.

This European Technical Assessment is issued in accordance with Regulation (EU) 305/2011, on the basis of

European Assessment Document EAD 350454-00-1104.

General comments

Translations of this European Technical Assessment in other languages shall fully correspond to the original issued document.

Communication of this European Technical Assessment, including transmission by electronic means, shall be in full (excepted the confidential Annex(es)).

Specific parts of the European Technical Assessment

1 Technical description of the product

AF SLEEVE is a services closure device used as fire pipe penetration seal, consisting of a fire protective intumescent strip.

AF SLEEVE is supplied in rolls of one size only and cut to a length to suit the external diameter of the service to be protected. The intumescent strip can also be placed in a plastic envelope, which has not been assessed in this ETA.

Table 1: Dimensions of AF SLEEVE.

Dimension	Nominal value	Tolerances
Thickness	4 mm	- 0 mm / + 0,8 mm
Width	50 mm	- 1 mm / + 2,5 mm

The description of the installation procedure is given in Annex A. Assembled penetration seals require additional components as described in Annex B. These components cannot be CE marked based on this ETA.

2 Specification of the intended use(s) in accordance with the applicable EAD

AF SLEEVE is used to reinstate the resistance to fire performance of rigid wall and rigid floor constructions where they are penetrated by services (combustible pipes). The detailed specification of the services that may be protected with AF SLEEVE are given in Annex B.

The specific elements of construction, where the AF SLEEVE may be used to provide a penetration seal in, are as follows:

- Rigid walls: Concrete or masonry walls with a minimum thickness of 150 mm and a minimum density of 500 kg/m³.
- Rigid floors: Light weight concrete or other type of rigid floors with a minimum thickness of 150 mm and a minimum density of 1600 kg/m³.

The constructive element where the intumescent strips are installed must be classified in accordance with EN 13501-2¹ for the required fire resistance period.

¹ EN 13501-2 Fire classification of construction products and building elements. Part 2: Classification using data from fire resistance tests, excluding ventilation services.

AF SLEEVE is intended for the environmental conditions as defined for use category Type $Y_{2,(-20/70)^{\circ}\text{C}}$ according to EAD 350454-00-1104: intended for semi-exposed use at temperatures below 0°C , but with no exposure to rain nor UV. Type $Y_{2,(-20/70)^{\circ}\text{C}}$ includes lower use categories (i.e. Type Z_1 and Type Z_2).

The provisions made in this ETA are based on a working life of AF SLEEVE of at least 10 years, provided that the conditions laid down in the manufacturer's instructions for the installation, use and maintenance are met. These provisions are based upon the current state of the art and the available knowledge and experience.

The indications given as to the working life of the product cannot be interpreted as a guarantee but are regarded only as a means for choosing the appropriate products in relation to the expected economically reasonable working life of the works.

3 Performance of the product and reference to the methods used for its assessment

3.1 Performance of the product

The assessment of AF SLEEVE has been performed in accordance with EAD 350454-00-1104 for *Penetration Seals (September 2017)*.

Table 2: Performance of the product.

Product: AF SLEEVE		Intended use: Fire penetration seal
Basic requirement	Essential characteristic	Performance
BWR 2 Safety in case of fire	Reaction to fire	E
	Resistance to fire	See Annex B
BWR 4 Safety and accessibility in use	Durability	Type $Y_{2,(-20/70)^{\circ}\text{C}}$

The rest of characteristics included in EAD 350454-00-1104 have not been assessed in this ETA.

3.2 Methods used for the assessment

3.2.1 Reaction to fire

The performance of AF SLEEVE has been tested according to EN ISO 11925-2² and determined according to EN 13501-1³ and Regulation (EU) 2016/364.

3.2.2 Fire resistance

The performance of AF SLEEVE has been tested and assessed according to EN 1366-3⁴. The classification of the resistance to fire has been determined according to EN 13501-2 and is given in Annex B.

3.2.3 Durability

AF SLEEVE has been tested and assessed for the environmental use category Type Y_{2, (-20/70)°C} in accordance with section 2.2.9 of EAD 350454-00-1104 and the EOTA Technical Report 024⁵, section 4.2.5, table 4.1.

4 Assessment and verification of constancy of performance (AVCP) system applied, with reference to its legal base

According to the Decision 1999/454/EC of the European Commission, the system of AVCP (see EC delegated Regulation (EU) No 568/2014 amending Annex V to Regulation (EU) 305/2011) given in the following table applies.

Table 3: AVCP System.

Product(s)	Intended use(s)	Level(s) or class(es)	System(s)
Fire stopping and fire sealing products	For fire compartmentation and/or fire protection or fire performance	Any	1

² EN ISO 11925-2 Reaction to fire tests. Ignitability of products subjected to direct impingement of flame. Part 2: Single-flame source test.

³ EN 13501-1 Fire classification of construction products and building elements. Part 1: Classification using data from reaction to fire tests.

⁴ EN 1366-3 Fire resistance tests for service installations. Part 3: Penetration seals (2009).

⁵ TR 024 Characterisation, Aspects of Durability and Factory Production Control for Reactive Materials, Components and Products, Edition July 2009.

5 Technical details necessary for the implementation of the AVCP system, as foreseen in the applicable EAD

All the necessary technical details for the implementation of the AVCP system are laid down in the *Control Plan* deposited with the ITeC and agreed in accordance with EAD 350454-00-1104, section 3.

The *Control Plan* is a confidential part of the ETA and only handed over to the notified product certification body involved in the assessment and verification of constancy of performance.

The factory production control operated by the manufacturer shall be in accordance with the above mentioned *Control Plan*.

Issued in Barcelona on 9 December 2019

by the Catalonia Institute of Construction Technology.



Ferran Bermejo Nualart
Technical Director, ITeC

ANNEX A. Description of the installation procedure

AF SLEEVE will be installed in accordance with the manufacturer instructions and the provisions established in this section and Annex B.

The intumescent strip is cut to a length to suit the external diameter of the protected service in accordance with the dimensions assessed in Annex B. The strip is manufactured at a nominal thickness of 4 mm and the total intumescent thickness of every installed sleeve (b in table A.1) is achieved by adding the required number of intumescent strip layers, depending on the external diameter of the protected service.

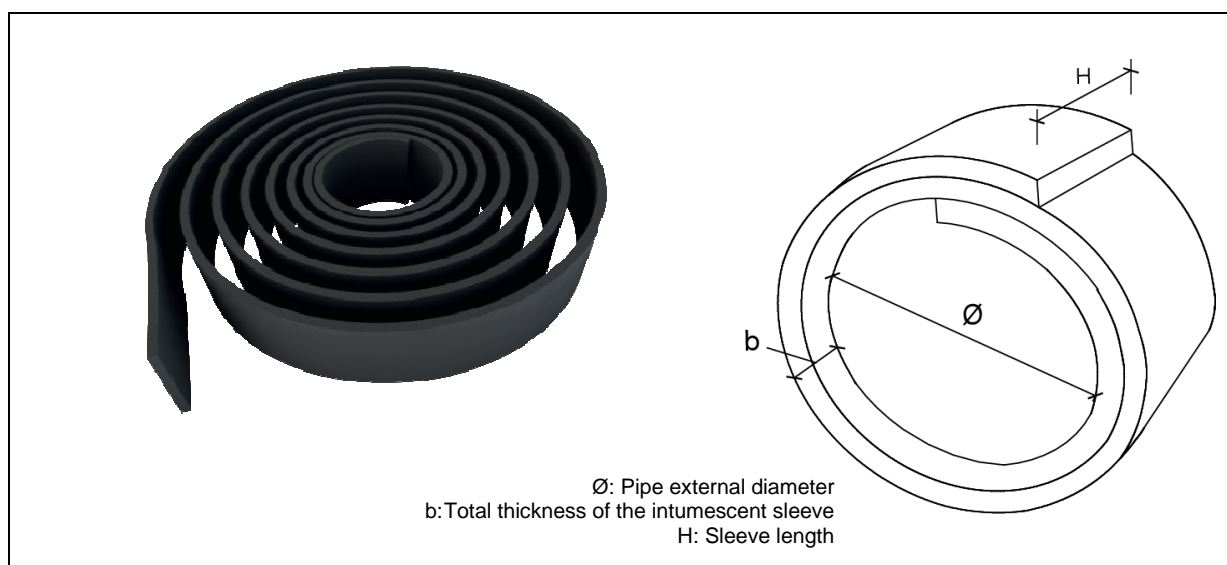

Figure A.1: General view of AF SLEEVE roll and dimensions of the installed sleeve.

Table A.1: Dimensions of installed AF SLEEVE.

Pipe external diameter (mm)	H (mm)	b (mm)	Nº of strip layers
≤ 110	50	8	2
$110 < \varnothing \leq 160$		12	3

AF SLEEVE is installed integrated into the constructive element (wall or floor), tightly fitted by pressure without mechanical fixing, wrapped around the service and keeping the strip edge levelled to the constructive element surface at the fire exposed side. The seal is finished with cement mortar. At the non-exposed side, the gap between the pipe and constructive element is also filled with cement mortar, spread over the constructive element surface around the penetration. All gaps between services and constructive elements will be of the same dimension as the total thickness of the installed sleeve (b in table A.1).

For pipe closure devices positioned within the building element, when the overall thickness of such an element is greater than the minimum specified (150 mm), the length of the seal will be increased accordingly and kept levelled at the element surface, in accordance with EN 1366-3.

The minimum distance between services penetrating the wall/floor, as well as the minimum distance between services and the constructive element edge, is 200 mm.

The maximum distance from the constructive element to the adequate service support is 500 mm in case of walls (cold side) and floors (upper side).

The following installation provisions will be noted:

- The installation of the penetration seal will not have an effect on the stability of the adjacent building element, even in the event of fire.
- The structural elements related to the wall/floor in which the penetration seal is incorporated will be designed and fire protected in such a way that no additional mechanical load is imposed on the penetration seal.
- The thermal movements of the pipework will be accommodated in such a way that no resulting load is imposed on the penetration seal.
- The services are fixed to the building element in such a way that no additional mechanical load is imposed on the penetration seal in the event of fire.
- The support of the services is maintained during the required period of resistance to fire.
- Pneumatic dispatch systems, compressed air systems, etc. are switched off in the event of fire.

ANNEX B. Resistance to fire performance

B.1. General

AF SLEEVE has been assessed for the following uses as penetration seal:

- Plastic pipes passing through a rigid wall: section B.2.1.
- Plastic pipes passing through a rigid floor: section B.2.2.

B.2. Plastic pipes

Regarding the material specification of those services included in this Annex B.2, pipes will be made from:

- PVC-U according to EN 1329-1⁶, EN 1453-1⁷ and EN ISO 1452-1⁸.
- PVC-C according to EN 1566-1⁹.
- PP according to EN 1451-1¹⁰.
- HDPE according to EN 1519-1¹¹ or EN 12666-1¹².
- PE according to EN 12201-2¹³, EN 1519-1 and EN 12666-1.
- ABS according to EN 1455-1¹⁴.
- SAN+PVC according EN 1565-1¹⁵.

Regarding the pipe end configuration, according to section 2.2.2 of EAD 350454-00-1104, a classification given for a configuration U/C is also valid for a pipe end configuration C/U and C/C. Definition of the pipe end configuration is given in section 6.3.4 of EN 1366-3.

Regarding the pipe diameter and pipe wall thickness, the rules for the field of direct application of the test results given in EN 1366-3 can be applied, i.e. resistance to fire classification given in this section B.2 is valid between the pipe diameters and pipe wall thicknesses as given in the tables, provided that AF SLEEVE is installed in accordance with Annex A.

-
- ⁶ EN 1329-1 Plastics piping systems for soil and waste discharge (low and high temperature) within the building structure. Unplasticized poly(vinyl chloride) (PVC-U). Part 1: Specifications for pipes, fittings and the system.
- ⁷ EN 1453-1 Plastics piping systems with structured wall-pipes for soil and waste discharge (low and high temperature) inside buildings. Unplasticized poly(vinyl chloride) (PVC-U). Part 1: Specifications for pipes and the system.
- ⁸ EN ISO 1452-1 Plastics piping systems for water supply and for buried and above-ground drainage and sewerage under pressure. Unplasticized poly(vinyl chloride) (PVC-U). Part 1: General (ISO 1452-1:2009).
- ⁹ EN 1566-1 Plastics piping systems for soil and waste discharge (low and high temperature) within the building structure. Chlorinated poly(vinyl chloride) (PVC-C). Part 1: Specifications for pipes, fittings and the system.
- ¹⁰ EN 1451-1 Plastics piping systems for soil and waste discharge (low and high temperature) within the building structure. Polypropylene (PP). Part 1: Specifications for pipes, fittings and the system.
- ¹¹ EN 1519-1 Plastics piping systems for soil and waste discharge (low and high temperature) within the building structure. Polyethylene (PE). Part 1: Specifications for pipes, fittings and the system.
- ¹² EN 12666-1 Plastics piping systems for non-pressure underground drainage and sewerage. Polyethylene (PE). Part 1: Specifications for pipes, fittings and the system.
- ¹³ EN 12201-2 Plastics piping systems for water supply, and for drainage and sewerage under pressure. Polyethylene (PE). Part 2: Pipes.
- ¹⁴ EN 1455-1 Plastics piping systems for soil and waste discharge (low and high temperature) within the building structure. Acrylonitrile-butadiene-styrene (ABS). Part 1: Requirements for pipes, fittings and the system.
- ¹⁵ EN 1565-1 Plastics piping systems for soil and waste discharge (low and high temperature) within the building structure. Styrene copolymer blends (SAN+PVC). Part 1: Specifications for pipes, fittings and the system.

B.2.1. Plastic pipes passing through a rigid wall

The rigid wall shall meet the specification given in section 2 of this ETA.

The relevant size (length cut from the roll and total thickness) of AF SLEEVE will be installed, in accordance with Annex A and the pipe diameter specified in tables B.2.1.1 to B.2.1.3, at the fire exposed side of the wall as shown in figure B.2.1.

The resistance to fire of the sealed combustible pipes is given in tables B.2.1.1 to B.2.1.3.

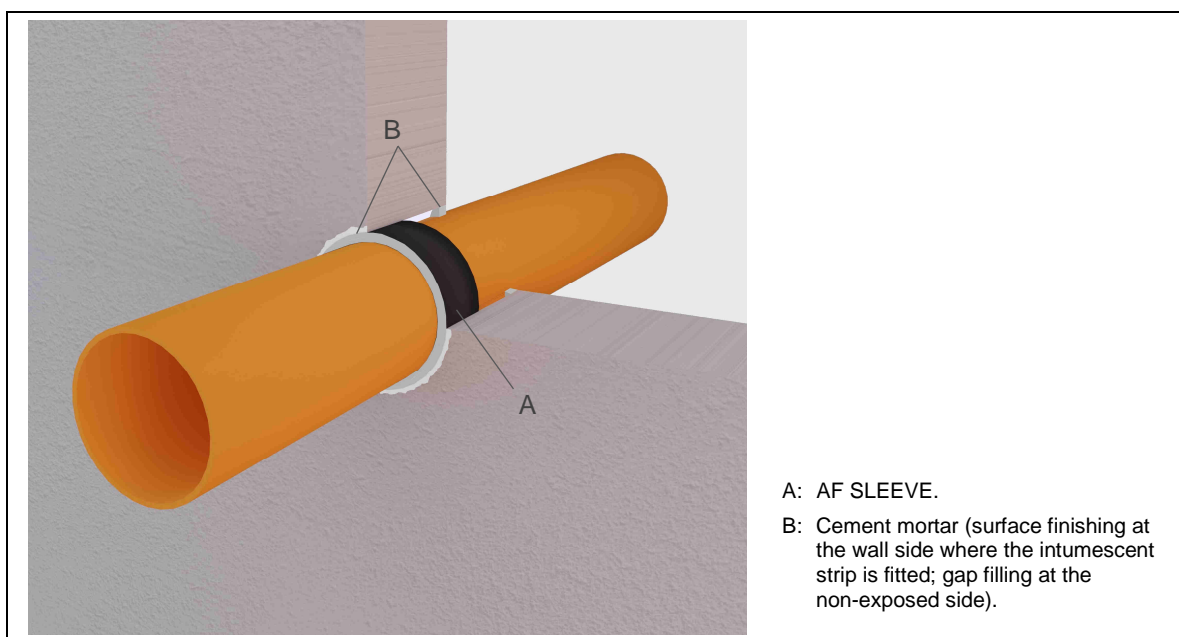

Figure B.2.1: Example of plastic pipe penetration seal in a rigid wall.

Table B.2.1.1: PVC pipes.

External pipe diameter [Ø] (mm)	Pipe wall thickness [t]		Resistance to fire class
	t _{min} (mm)	t _{max} (mm)	
≤ 110	3,2	8,1	EI 180 U/C
110 < Ø ≤ 160	3,2	11,0	

Table B.2.1.2: PP pipes.

External pipe diameter [Ø] (mm)	Pipe wall thickness [t]		Resistance to fire class
	t _{min} (mm)	t _{max} (mm)	
≤ 110	2,7	16,1	EI 180 U/C
110 < Ø ≤ 160	3,9	14,6	

Table B.2.1.3: HDPE, PE, ABS and SAN+PVC pipes.

External pipe diameter [Ø] (mm)	Pipe wall thickness [t]		Resistance to fire class
	t _{min} (mm)	t _{max} (mm)	
≤ 110	4,2	12,3	EI 180 U/C
110 < Ø ≤ 160	6,2	16,0	

B.2.2. Plastic pipes passing through a rigid floor

The rigid floor shall meet the specification given in section 2 of this ETA.

The relevant size (length cut from the roll and total thickness) of AF SLEEVE will be installed, in accordance with Annex A and the pipe diameter specified in tables B.2.2.1 to B.2.2.3, at the bottom side of the floor as shown in figure B.2.2.

The resistance to fire of the sealed combustible pipes is given in tables B.2.2.1 to B.2.2.3.

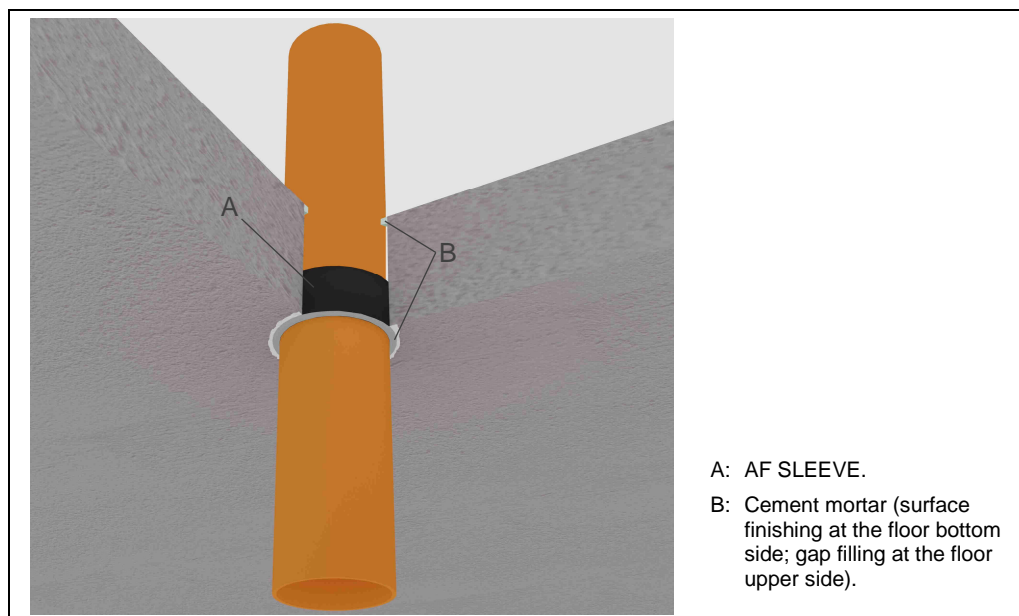

Figure B.2.2: Example of plastic pipe penetration seal in a rigid floor.

Table B.2.2.1: PVC pipes.

External pipe diameter [Ø] (mm)	Pipe wall thickness [t]		Resistance to fire class
	t _{min} (mm)	t _{max} (mm)	
≤ 110	3,2	8,1	EI 180 U/C
110 < Ø ≤ 160	3,2	11,0	

Table B.2.2.2: PP pipes.

External pipe diameter [Ø] (mm)	Pipe wall thickness [t]		Resistance to fire class
	t _{min} (mm)	t _{max} (mm)	
≤ 110	3,2	8,1	EI 180 U/C
110 < Ø ≤ 160	3,2	11,0	

Table B.2.2.3: HDPE, PE, ABS and SAN+PVC pipes.

External pipe diameter [Ø] (mm)	Pipe wall thickness [t]		Resistance to fire class
	t _{min} (mm)	t _{max} (mm)	
≤ 110	3,2	8,1	EI 180 U/C
110 < Ø ≤ 160	3,2	15,0	