



**The Catalonia
Institute of Construction
Technology**

Wellington 19
ES-08018 Barcelona
Tel. +34 93 309 34 04
qualprod@itec.cat
itec.cat



www.eota.eu

European Technical Assessment

**ETA 18/0099
of 02.05.2022**



General part

Technical Assessment Body issuing the ETA: ITeC

ITeC has been designated according to Article 29 of Regulation (EU) No 305/2011 and is member of EOTA (European Organisation for Technical Assessment).

Trade name of the construction product

ALFA 29, ALFA 30, ALFA 30 INOX, ALFA 31, ALFA 32, BETA 3070, BETA 30 and BETA 50

Product family to which the construction product belongs

Multi-axis concealed hinge assemblies.

Manufacturer

INTHER H&S SLU
Ibsen 17
ES-29004 Málaga
Spain

Manufacturing plant(s)

According to annex N kept by ITeC.

This European Technical Assessment contains

23 pages including 3 annexes which form an integral part of this assessment

and

Annex N, which contains confidential information and is not included in the European Technical Assessment when that assessment is publicly available.

This European Technical Assessment is issued in accordance with Regulation (EU) 305/2011, on the basis of

European Assessment Document EAD 020001-01-0405.

This version replaces

ETA 18/0099 issued on 27.04.2018.

General comments

Translations of this European Technical Assessment in other languages shall fully correspond to the original issued document.

Communication of this European Technical Assessment, including transmission by electronic means, shall be in full (excepted the confidential annex(es)).

Specific parts of the European Technical Assessment

1 Technical description of the product

ALFA 29, ALFA 30, ALFA 30 INOX, ALFA 31, ALFA 32, BETA 3070, BETA 30 and BETA 50 are multi-axis concealed hinge assemblies. The products consist of three parts: a door frame mounting body, a door mounting body and a connecting device linking the mounting bodies together in such a way as to allow the door to swing freely and to maintain the rotation axis of the leaf perpendicular to a horizontal plane during the full operational cycle. The connecting device provides a variable geometry within the multi-axis concealed hinge assemblies.

The different components of ALFA 29, ALFA 30, ALFA 31, ALFA 32, BETA 3070, BETA 30 and BETA 50 are mainly made of galvanised steel and zamac. ALFA 30 INOX is made of stainless steel.

The products have been assessed with different coatings as follows:

- ALFA 29: ALFA 29 CR, ALFA 29 ORO, ALFA 29 PL.
- ALFA 30: ALFA 30 BL, ALFA 30 CR, ALFA 30 CS, ALFA 30 NE, ALFA 30 ORO, ALFA 30 PL.
- ALFA 31: ALFA 31 CR, ALFA 31 CS, ALFA 31 NE, ALFA 31 ORO, ALFA 31 PL.
- ALFA 32: ALFA 32 BL, ALFA 32 CR, ALFA 32 NE, ALFA 32 ORO, ALFA 32 PL, ALFA 32 CS.
- BETA 3070: BETA 3070 BL, BETA 3070 CS, BETA 3070 NE, BETA 3070 ORO, BETA 3070 PL.
- BETA 30: BETA 30 BL, BETA 30 CS, BETA 30 NE, BETA 30 PL, BETA 30 ORO, BETA 30 CR.
- BETA 50: BETA 50 BL, BETA 50 CS, BETA 50 NE, BETA 50 ORO, BETA 50 PL, BETA 50 CR.

The multi-axis concealed hinge assemblies are described in Annex 1.

2 Specification of the intended use(s) in accordance with the applicable EAD

The invisible (concealed) hinges are intended for use on doors made of timber, metal or synthetic materials, allowing single and double swing door leaves to be mounted flush to its frame, forming a flush panel surface when the door is closed, and allowing the door to open to 180°.

The category of use of the hinges and the maximum door mass (each leaf, mass per 2 hinges) are given in the next table in accordance with EAD 020001-01-0405 and EN 1935¹.

Table 1: Intended of use of the hinges.

Product	Category of use		Door mass	
	Grade	Duty	Grade	Mass (kg)
ALFA 29	2	Medium	1	20
ALFA 30	2	Medium	2	40
ALFA 30 INOX	2	Medium	2	40
ALFA 31	3	Heavy	4	80
ALFA 32	2	Medium	2	40
BETA 3070	2	Medium	2	40
BETA 30	2	Medium	2	40
BETA 50	4	Severe	6	120

ALFA 31, BETA 3070 and BETA 50 are intended for use in fire resisting and/or smoke control doors and/or doors on escape routes (see tables 5, 7 and 9, and Annex 2).

The provisions made in this ETA are based on a working life of the products of at least 10 years, provided that the conditions laid down in the manufacturer's instructions for the installation, use and maintenance are met. These provisions are based upon the current state of the art and the available knowledge and experience.

The indications given as to the working life cannot be interpreted as a guarantee given by the producer or Assessment Body, but are to be regarded only as a means for choosing the appropriate product(s) in relation to the expected economically reasonable working life of the works.

¹ EN 1935. Building hardware. Single axis hinges. Requirements and test methods.

3 Performance of the product and reference to the methods used for its assessment

3.1 Performance of the product

The assessment of the ALFA 29, ALFA 30, ALFA 30 INOX, ALFA 31, ALFA 32, BETA 3070, BETA 30 and BETA 50 has been performed in accordance with EAD 020001-01-0405 *Multi-axis concealed hinge assemblies (March 2017)*.

Performance of the products is given in the next tables. Information is also shown in Annex 3 following the classification system established in EN 1935.

Table 2: Performance of ALFA 29.

Product: ALFA 29		Intended use: Multi-axis concealed hinge assembly
Basic requirement	Essential characteristic	Performance
BWR 2 Safety in case of fire	Reaction to fire	NPA ² (see 3.2.1)
	Resistance to fire	NPA – Grade 0
BWR 4 Safety and accessibility in use	Permanent function (durability)	200.000 cycles – Grade 7
	Friction torque	≤ 2 N·m
	Load deformation	40 kg Test door mass grade 1 (20 kg)
	Overload	60 kg Test door mass grade 1 (20 kg)
	Safety	Grade 1
	Corrosion	ALFA 29 CR
ALFA 29 ORO		Not defined – Grade 0
ALFA 29 PL		High resistance – Grade 3
Hinge grade		Grade 4

² NPA: No Performance Assessed.

Table 3: Performance of ALFA 30.

Product: ALFA 30		Intended use: Multi-axis concealed hinge assembly	
Basic requirement	Essential characteristic	Performance	
BWR 2 Safety in case of fire	Reaction to fire	NPA (see 3.2.1)	
	Resistance to fire	NPA – Grade 0	
BWR 4 Safety and accessibility in use	Permanent function (durability)	200.000 cycles – Grade 7	
	Friction torque	≤ 2 N·m	
	Load deformation	80 kg Test door mass grade 2 (40 kg)	
	Overload	120 kg Test door mass grade 2 (40 kg)	
	Safety	Grade 1	
	Corrosion	ALFA 30 BL	Mild resistance – Grade 1
		ALFA 30 CR	Not defined – Grade 0
		ALFA 30 CS	Not defined – Grade 0
		ALFA 30 NE	Not defined – Grade 0
		ALFA 30 ORO	Not defined – Grade 0
ALFA 30 PL		High resistance – Grade 3	
Hinge grade		Grade 7	

Table 4: Performance of ALFA 30 INOX.

Product: ALFA 30 INOX		Intended use: Multi-axis concealed hinge assembly
Basic requirement	Essential characteristic	Performance
BWR 2 Safety in case of fire	Reaction to fire	NPA (see 3.2.1)
	Resistance to fire	NPA – Grade 0
BWR 4 Safety and accessibility in use	Permanent function (durability)	200.000 cycles – Grade 7
	Friction torque	≤ 2 N·m
	Load deformation	80 kg Test door mass grade 2 (40 kg)
	Overload	120 kg Test door mass grade 2 (40 kg)
	Safety	Grade 1
	Corrosion	Very high resistance – Grade 4
	Hinge grade	

Table 5: Performance of ALFA 31.

Product: ALFA 31		Intended use: Multi-axis concealed hinge assembly	
Basic requirement	Essential characteristic	Performance	
BWR 2 Safety in case of fire	Reaction to fire	NPA (see 3.2.1)	
	Resistance to fire	Grade 1 (see Annex 2)	
BWR 4 Safety and accessibility in use	Permanent function (durability)	200.000 cycles – Grade 7	
	Friction torque	≤ 3 N·m	
	Load deformation	160 kg Test door mass grade 4 (80 kg)	
	Overload	240 kg Test door mass grade 4 (80 kg)	
	Safety	Grade 1	
	Corrosion	ALFA 31 CR	Not defined – Grade 0
		ALFA 31 CS	Not defined – Grade 0
		ALFA 31 NE	Not defined – Grade 0
		ALFA 31 ORO	Not defined – Grade 0
		ALFA 31 PL	High resistance – Grade 3
Hinge grade	Grade 11		

Table 6: Performance of ALFA 32.

Product: ALFA 32		Intended use: Multi-axis concealed hinge assembly	
Basic requirement	Essential characteristic	Performance	
BWR 2 Safety in case of fire	Reaction to fire	NPA (see 3.2.1)	
	Resistance to fire	NPA – Grade 0	
BWR 4 Safety and accessibility in use	Permanent function (durability)	200.000 cycles – Grade 7	
	Friction torque	≤ 2 N·m	
	Load deformation	80 kg Test door mass grade 2 (40 kg)	
	Overload	120 kg Test door mass grade 2 (40 kg)	
	Safety	Grade 1	
	Corrosion	ALFA 32 BL	Mild resistance – Grade 1
		ALFA 32 CR	Not defined – Grade 0
		ALFA 32 NE	Not defined – Grade 0
		ALFA 32 ORO	Not defined – Grade 0
		ALFA 32 CS	Not defined – Grade 0
ALFA 32 PL	High resistance – Grade 3		
Hinge grade	Grade 7		

Table 7: Performance of BETA 3070.

Product: BETA 3070		Intended use: Multi-axis concealed hinge assembly
Basic requirement	Essential characteristic	Performance
BWR 2 Safety in case of fire	Reaction to fire	NPA (see 3.2.1)
	Resistance to fire	Grade 1 (see Annex 2)
BWR 4 Safety and accessibility in use	Permanent function (durability)	200.000 cycles – Grade 7
	Friction torque	≤ 2 N·m
	Load deformation	80 kg Test door mass grade 2 (40 kg)
	Overload	120 kg Test door mass grade 2 (40 kg)
	Safety	Grade 1
	Corrosion	Not defined – Grade 0
Hinge grade		Grade 7

Table 8: Performance of BETA 30.

Product: BETA 30		Intended use: Multi-axis concealed hinge assembly
Basic requirement	Essential characteristic	Performance
BWR 2 Safety in case of fire	Reaction to fire	NPA (see 3.2.1)
	Resistance to fire	NPA – Grade 0
BWR 4 Safety and accessibility in use	Permanent function (durability)	200.000 cycles – Grade 7
	Friction torque	≤ 2 N·m
	Load deformation	80 kg Test door mass grade 2 (40 kg)
	Overload	120 kg Test door mass grade 2 (40 kg)
	Safety	Grade 1
	Corrosion	Not defined – Grade 0
Hinge grade		Grade 7

Table 9: Performance of BETA 50.

Product: BETA 50		Intended use: Multi-axis concealed hinge assembly
Basic requirement	Essential characteristic	Performance
BWR 2 Safety in case of fire	Reaction to fire	NPA (see 3.2.1)
	Resistance to fire	Grade 1 (see Annex 2)
BWR 4 Safety and accessibility in use	Permanent function (durability)	200.000 cycles – Grade 7
	Friction torque	≤ 4 N·m
	Load deformation	240 kg Test door mass grade 6 (120 kg)
	Overload	360 kg Test door mass grade 6 (120 kg)
	Safety	Grade 1
	Corrosion	Not defined – Grade 0
Hinge grade		Grade 13

3.2 Methods used for the assessment

3.2.1 Reaction to fire

Performance not assessed.

Characteristic not relevant for the hinges according to the existing harmonised technical specifications for doors.

3.2.2 Fire resistance

Fire resistance performance of ALFA 31, BETA 3070 and BETA 50, assembled in a fire resistant door, has been tested according to EN 1634-1³ and classified to EN 13501-2⁴.

Relevant information is given in Annex 2.

3.2.3 Permanent function (durability)

Permanent function (durability) has been tested in accordance with EN 1935 and section 2.2.3 of EAD 020001-01-0405.

³ EN 1634-1. Fire resistance and smoke control tests for door and shutter assemblies, openable windows and elements of building hardware. Part 1: Fire resistance test for door and shutter assemblies and openable windows.

⁴ EN 13501-2. Fire classification of construction products and building elements. Part 2: Classification using data from fire resistance tests, excluding ventilation services implemented.

3.2.4 Friction torque

Friction torque has been tested according to EN 1935 and assessed to EAD 020001-01-0405.

3.2.5 Load deformation

Load deformation has been tested according to EN 1935 and assessed to EAD 020001-01-0405.

3.2.6 Overload

Overload has been tested according to EN 1935 and assessed to EAD 020001-01-0405.

3.2.7 Safety

Safety has been classified according to clause 4.6 of EN 1935.

3.2.8 Corrosion resistance

The hinges have been tested according to EN 1670⁵ and section 2.2.5 of EAD 020001-01-0405.

⁵ EN 1670. Building hardware. Corrosion resistance. Requirements and test methods.

4 Assessment and verification of constancy of performance (AVCP) system applied, with reference to its legal base

According to the Decision 1999/93/EC of the European Commission, the system of AVCP (see EC Delegated Regulation (EU) No 568/2014 amending Annex V to Regulation (EU) 305/2011) given in the following table applies.

Table 7: AVCP System.

Product(s)	Intended use(s)	Level(s) or class(es)	System(s)
Building hardware related to doors and gates	Fire/smoke compartmentation and on escape route	Any	1

5 Technical details necessary for the implementation of the AVCP system, as foreseen in the applicable EAD

All the necessary technical details for the implementation of the AVCP system are laid down in the Control Plan deposited with the ITeC and agreed in accordance with EAD 020001-01-0405, section 3.

The Control Plan is a confidential part of the ETA and only handed over to the notified product certification body involved in the assessment and verification of constancy of performance.

The factory production control operated by the manufacturer shall be in accordance with the above mentioned Control Plan.

Issued in Barcelona on 02 May 2022

by the Catalonia Institute of Construction Technology.



Ferran Bermejo Nualart
Technical Director, ITeC

ANNEX 1. Technical description of the hinges

A.1.1. ALFA 29 overall drawing

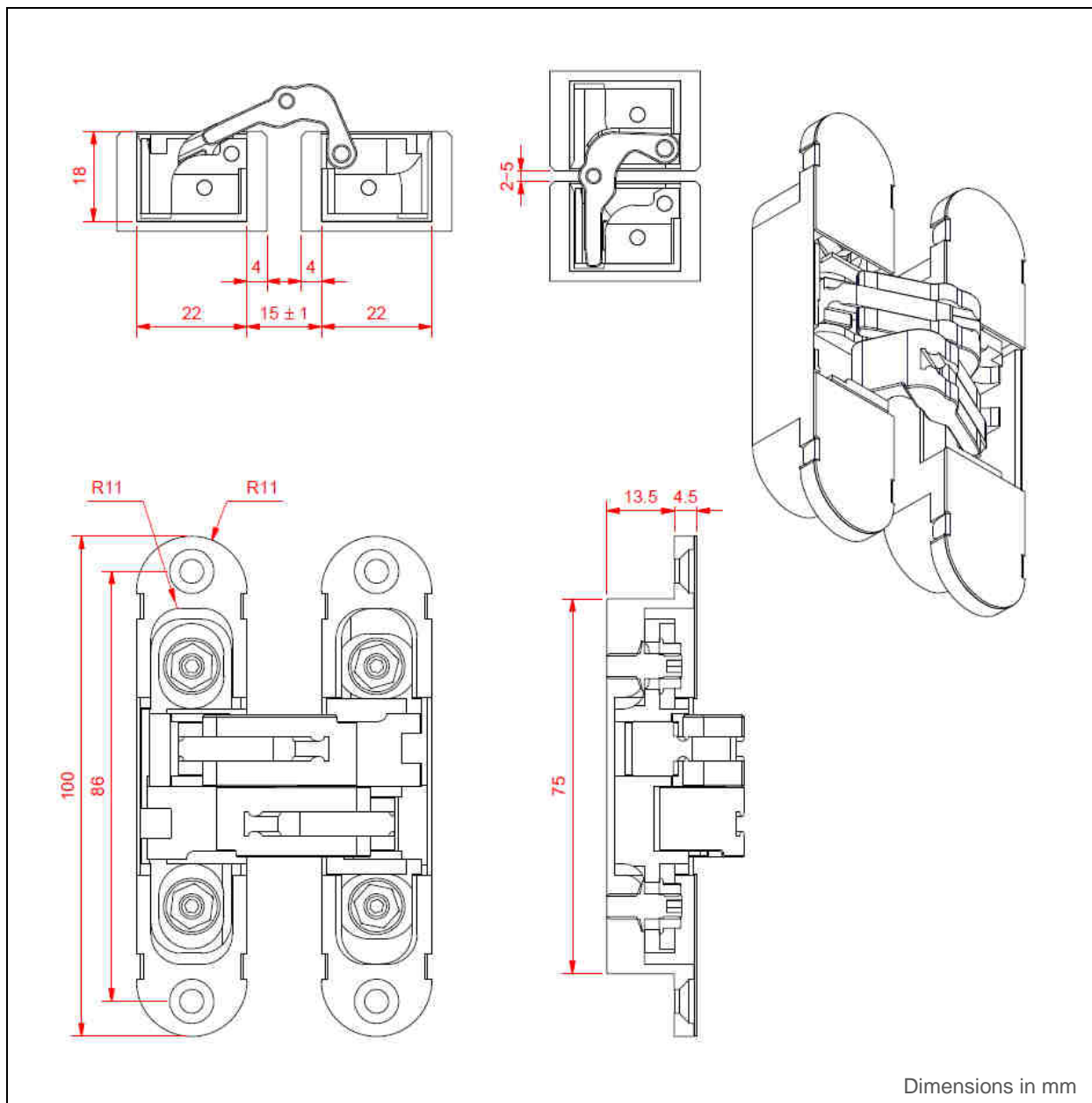

A.1.2. ALFA 30 overall drawing

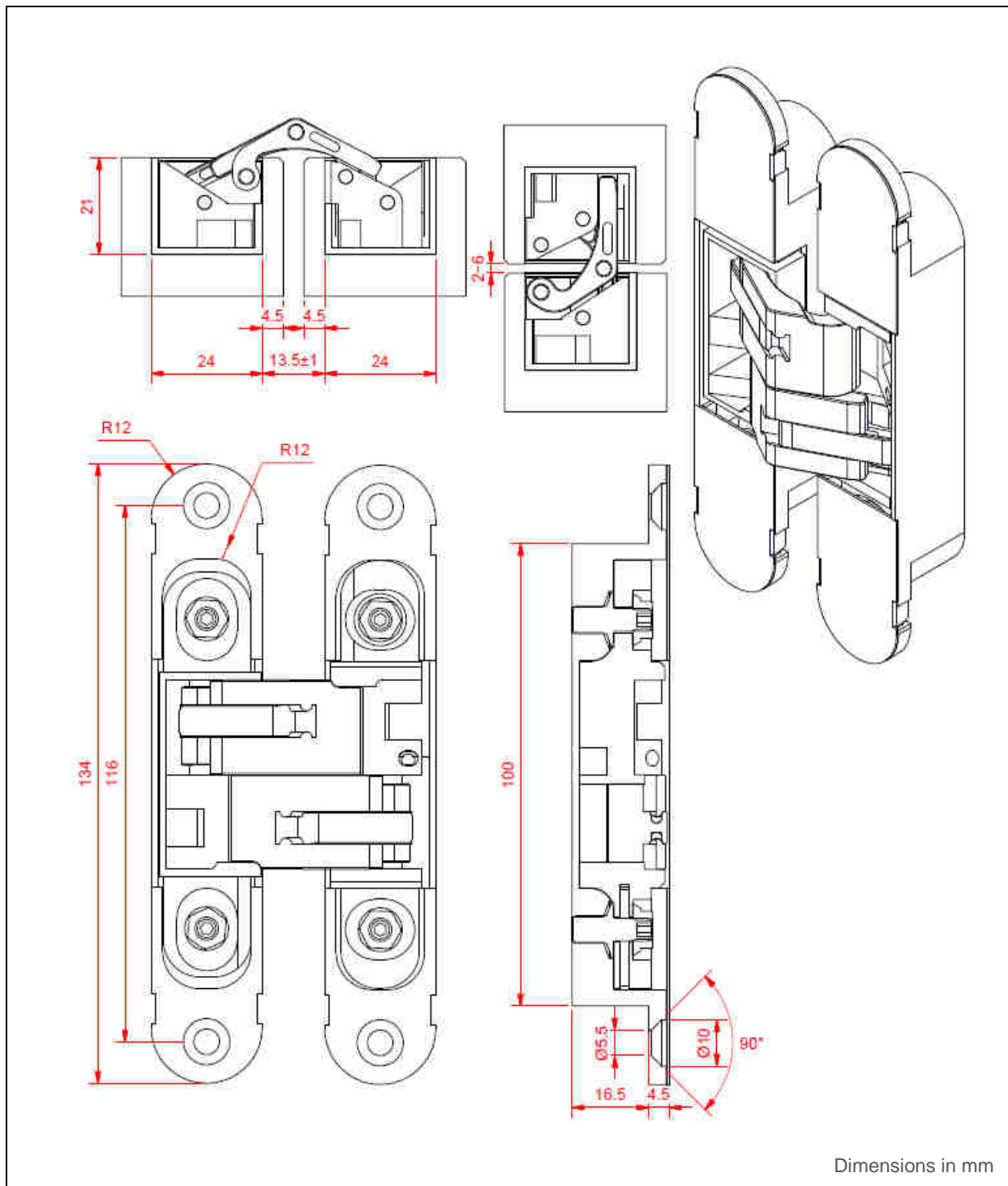

A.1.3. ALFA 30 INOX overall drawing

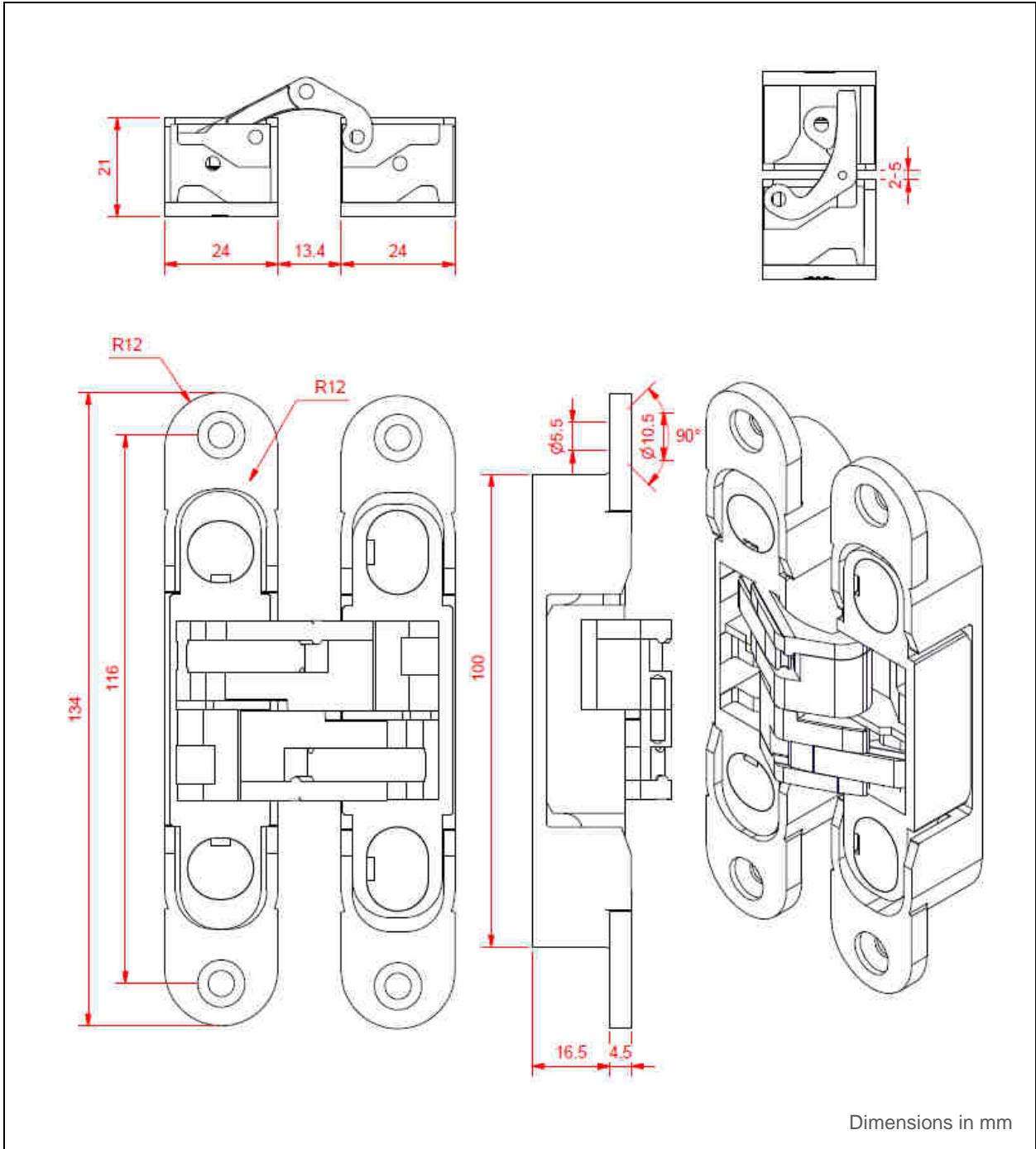

A.1.4. ALFA 31 overall drawing

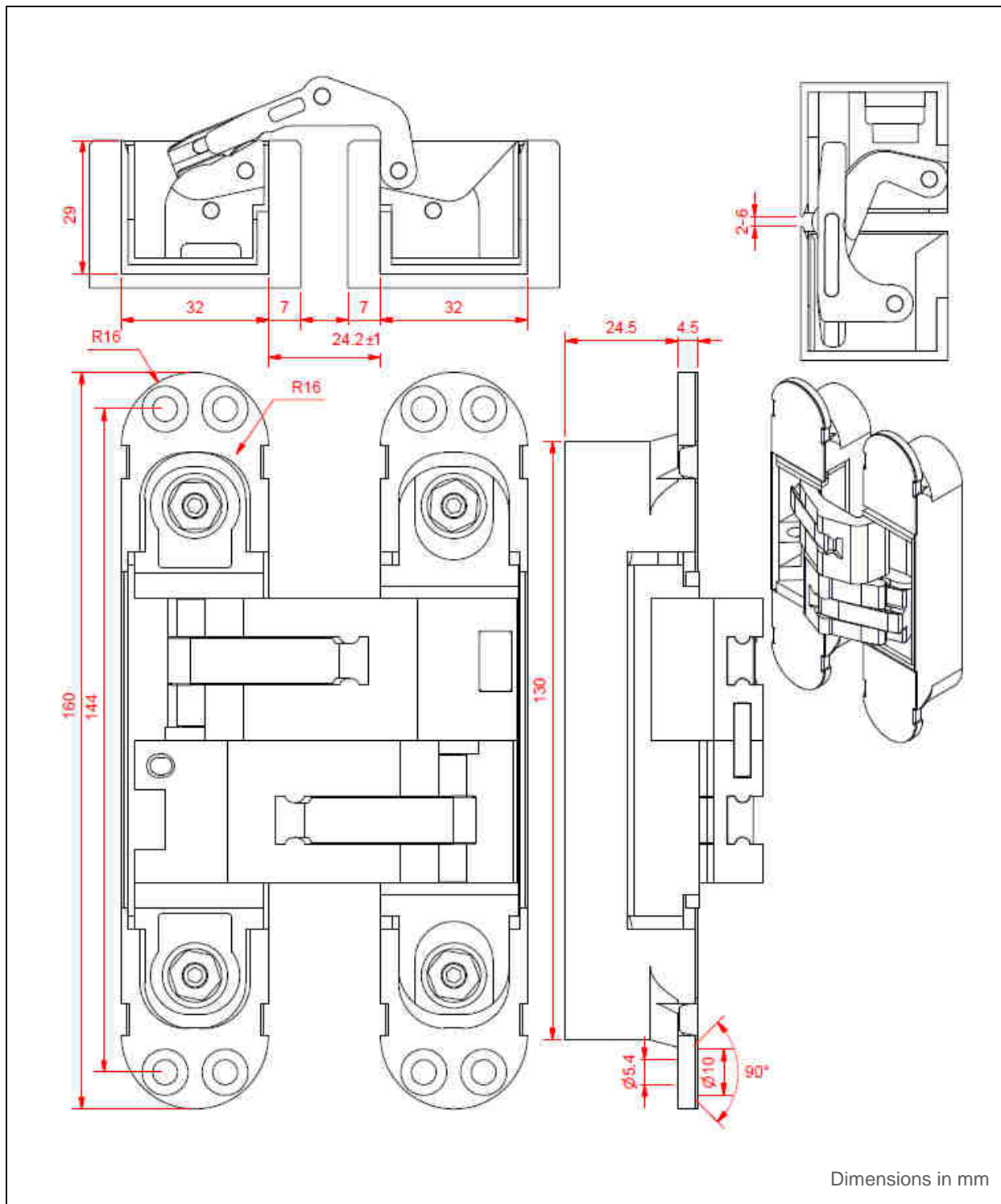

A.1.5. ALFA 32 overall drawing

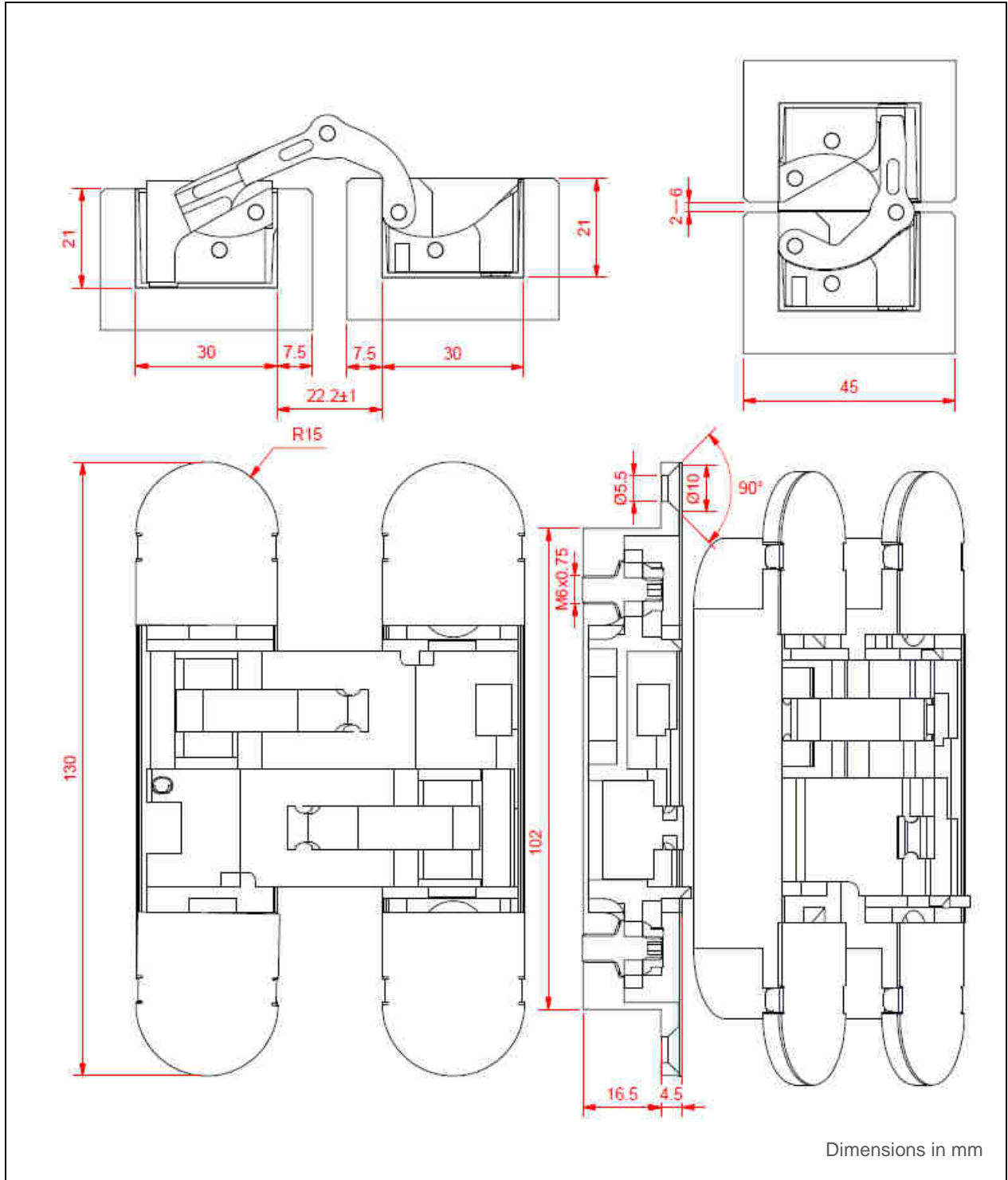

A.1.6. BETA 3070 overall drawing

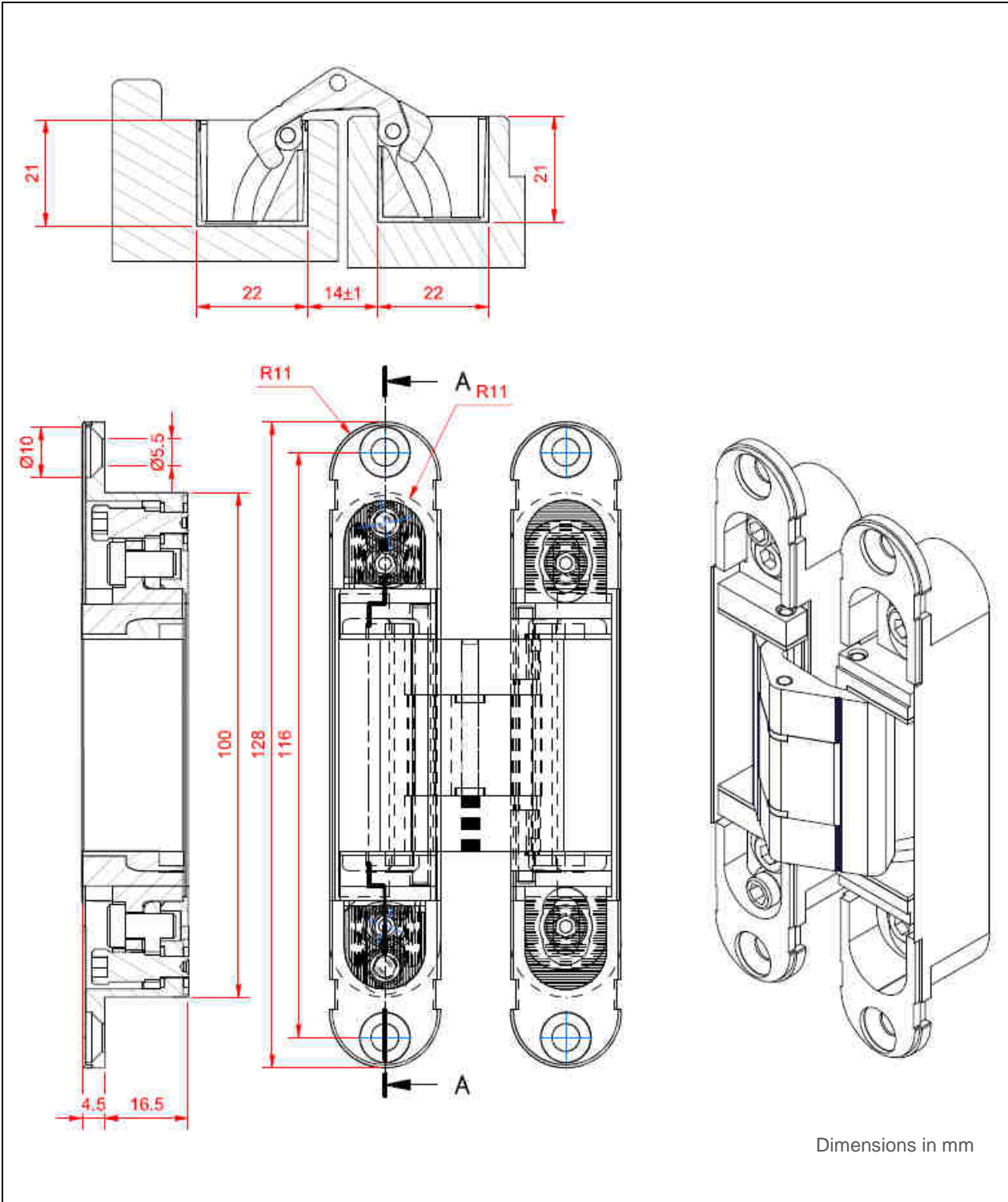

A.1.7. BETA 30 overall drawing

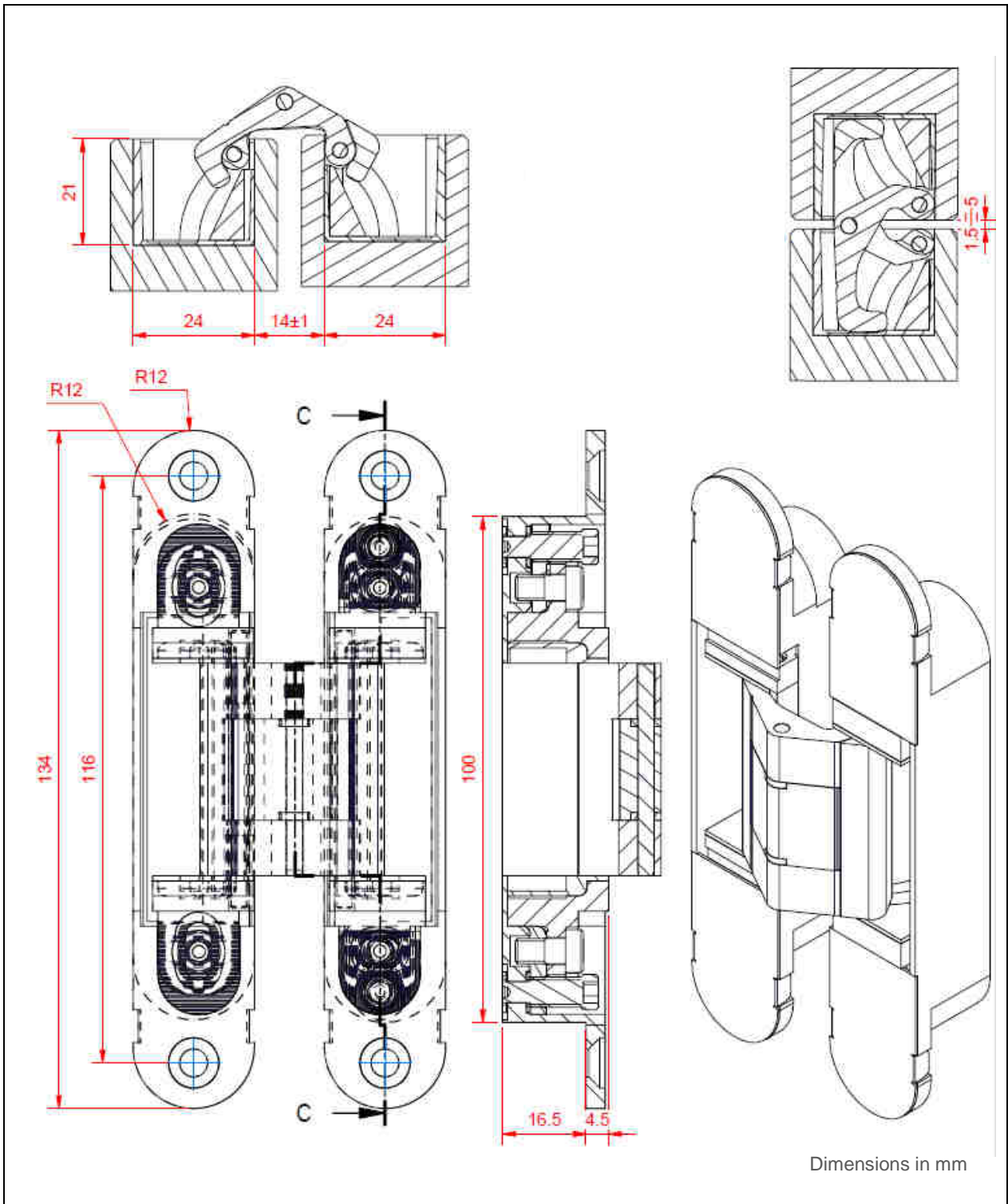

A.1.8. BETA 50 overall drawing

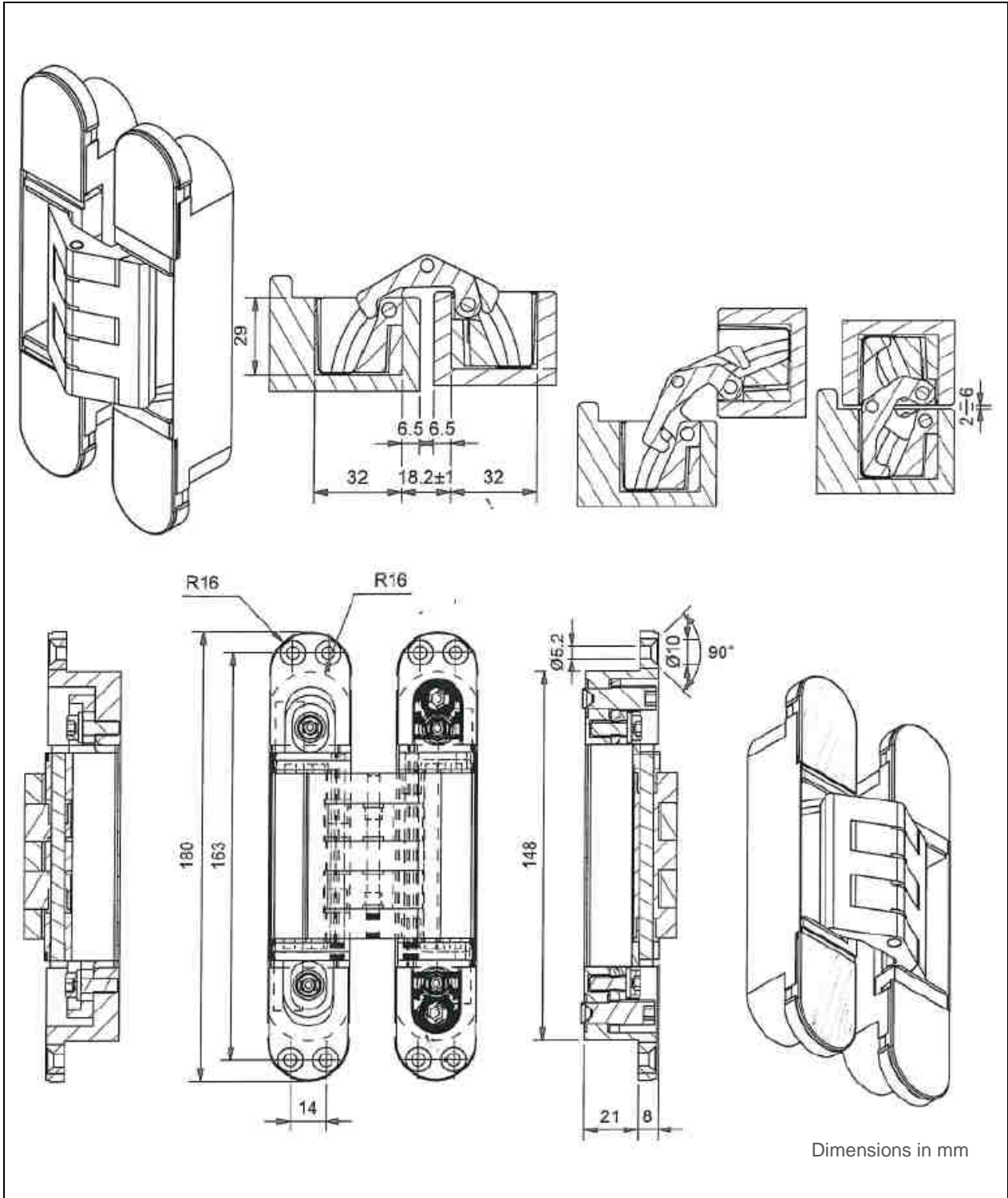

ANNEX 2. Resistance to fire performance

A.2.1. General

Resistance to fire performance of ALFA 31, BETA 3070 and BETA 50 has been assessed in accordance with EAD 020001-01-0405 and the product is classified as grade 1 in accordance with EN 1935.

ALFA 31, BETA 3070 and BETA 50 have been tested according to EN 1634-1 as a part of the fire resisting doors specified in this annex. For further details on the assembly tested, the performance and the results field of application, see relevant test and classification reports.

A.2.2. Resistance to fire performance of ALFA 31

Table A2.1: ALFA 31 assembled in door "PC-EI-BO-55 mm 1 HOJA".

Classification	EI ₁ 45 EI ₂ 45 (Door opening inwards the furnace)
Test & classification report	Applus 16/12320-934 Part 1 & 2
Door reference	PC-EI-BO-55 mm 1 HOJA
Door manufacturer	MARCOS MARTÍNEZ MINGUELA SA
Door general description (as tested)	Hinged timber single leaf door Overall dimensions (height x width x thickness): 2210 mm x 1125 mm x 55 mm Overall weight (leaf): 85,6 kg 3 x ALFA 31 (centres at 305 mm, 1135 mm and 1965 mm from the bottom)

Table A2.2: ALFA 31 assembled in door "PC-EI-BO-55 mm 1 HOJA".

Classification	EI ₁ 30 EI ₂ 30 (Door opening outwards the furnace)
Test & classification report	Applus 16/12622-1275 Part 1 & 2
Door reference	PC-EI-BO-55 mm 1 HOJA
Door manufacturer	MARCOS MARTÍNEZ MINGUELA SA
Door general description (as tested)	Hinged timber single leaf door Overall dimensions (height x width x thickness): 2190 mm x 1085 mm x 55 mm Overall weight (leaf): 80 kg 3 x ALFA 31 (centres at 135 mm, 965 mm and 1795 mm from the bottom)

Table A2.3: ALFA 31 assembled in door "X397".

Classification	EI ₁ 120 EI ₂ 120 (Door opening inwards the furnace)
Test & classification report	Applus 17/14097-794 Part 1 & 2
Door reference	X397
Door manufacturer	CEAM AMADEO SPA
Door general description (as tested)	Hinged timber single leaf door Overall dimensions (height x width x thickness): 2530 mm x 1130 mm x 120 mm Overall weight (leaf): 207 kg 5 x ALFA 31 (centres at 290 mm, 990 mm, 1860 mm, 2075 mm and 2325 mm from the bottom)

A.2.3. Resistance to fire performance of BETA 3070

Table A2.4: BETA 3070 assembled in door "PUERTA CORTAFUEGOS FILOMURO DE 45 mm CON MARCO DE ALUMINIO MODELO 1".

Classification	EI ₁ 30 EI ₂ 30 (Door opening inwards the furnace)
Test & classification report	Applus 21/25381-1183 & 21/25381-1183-1
Door reference	PUERTA CORTAFUEGOS FILOMURO DE 45 mm CON MARCO DE ALUMINIO MODELO 1
Door manufacturer	MARCOS MARTÍNEZ MINGUELA SA
Door general description (as tested)	Hinged timber single leaf door with aluminium frame Overall dimensions (height x width x thickness): 2150 mm x 925 mm x 45 mm Overall weight (leaf): 51 kg 4 x BETA 3070 (centres at 197 mm, 928,5 mm and 1660 mm from the bottom, and centre of the upper hinge at 200 mm from the top)

Table A2.5: BETA 3070 assembled in door "PUERTA CORTAFUEGOS FILOMURO DE 45 mm CON MARCO DE ALUMINIO MODELO 1".

Classification	EI ₁ 30 EI ₂ 30 (Door opening outwards the furnace)
Test & classification report	Applus 21/25381-1183 & 21/25381-1183-2
Door reference	PUERTA CORTAFUEGOS FILOMURO DE 45 mm CON MARCO DE ALUMINIO MODELO 1
Door manufacturer	MARCOS MARTÍNEZ MINGUELA SA
Door general description (as tested)	Hinged timber single leaf door with aluminium frame Overall dimensions (height x width x thickness): 2150 mm x 925 mm x 45 mm Overall weight (leaf): 51 kg 4 x BETA 3070 (centres at 197 mm, 928,5 mm and 1660 mm from the bottom, and centre of the upper hinge at 200 mm from the top)

A.2.4. Resistance to fire performance of BETA 50

Table A2.6: BETA 50 assembled in door "PCM 65 mm_03".

Classification	EI ₂ 60 (Door opening inwards the furnace)
Test & classification report	Applus 22/32301493
Door reference	PCM 65 mm_03
Door manufacturer	Puertas Cortafuego de Madera
Door general description (as tested)	Hinged timber single leaf door with timber frame Overall dimensions (height x width x thickness): 2380 mm x 1210 mm x 65 mm Overall weight (leaf): 123 kg 4 x BETA 50 (centres at 131 mm, 698 mm, 1455 mm y 2084 mm from the top)

ANNEX 3. Performance shown following EN 1935 classification system

Performance of the products, given in section 3.1, is also shown in the next tables according to the classification system established in EN 1935.

Table A3.1: Performance of ALFA 29 following EN 1935 classification system.

ALFA 29 CR	2	7	1	0	1	0	0	4
ALFA 29 ORO	2	7	1	0	1	0	0	4
ALFA 29 PL	2	7	1	0	1	3	0	4

Table A3.2: Performance of ALFA 30 following EN 1935 classification system.

ALFA 30 BL	2	7	2	0	1	1	0	7
ALFA 30 CR	2	7	2	0	1	0	0	7
ALFA 30 CS	2	7	2	0	1	0	0	7
ALFA 30 NE	2	7	2	0	1	0	0	7
ALFA 30 ORO	2	7	2	0	1	0	0	7
ALFA 30 PL	2	7	2	0	1	3	0	7

Table A3.3: Performance of ALFA 30 INOX following EN 1935 classification system.

ALFA 30 INOX	2	7	2	0	1	4	0	7
--------------	---	---	---	---	---	---	---	---

Table A3.4: Performance of ALFA 31 following EN 1935 classification system.

ALFA 31 CR	3	7	4	1	1	0	0	11
ALFA 31 CS	3	7	4	1	1	0	0	11
ALFA 31 NE	3	7	4	1	1	0	0	11
ALFA 31 ORO	3	7	4	1	1	0	0	11
ALFA 31 PL	3	7	4	1	1	3	0	11

Table A3.5: Performance of ALFA 32 following EN 1935 classification system.

ALFA 32 BL	2	7	2	0	1	1	0	7
ALFA 32 CR	2	7	2	0	1	0	0	7
ALFA 32 NE	2	7	2	0	1	0	0	7
ALFA 32 ORO	2	7	2	0	1	0	0	7
ALFA 32 CS	2	7	2	0	1	0	0	7
ALFA 32 PL	2	7	2	0	1	3	0	7

Table A3.6: Performance of BETA 3070 following EN 1935 classification system.

BETA 3070	2	7	2	1	1	0	0	7
-----------	---	---	---	---	---	---	---	---

Table A3.7: Performance of BETA 30 following EN 1935 classification system.

BETA 30	2	7	2	0	1	0	0	7
---------	---	---	---	---	---	---	---	---

Table A3.8: Performance of BETA 50 following EN 1935 classification system.

BETA 50	4	7	6	1	1	0	0	13
---------	---	---	---	---	---	---	---	----