



**Institut de  
Tecnologia de la Construcció  
de Catalunya**

Wellington 19  
ES08018 Barcelona  
Phone +34 933 09 34 04  
E-mail: qualprod@itec.cat  
Website: itec.cat



Member of



www.eota.eu

## European Technical Assessment

**ETA 17/0871**  
of 22.11.2017



### General part

#### Technical Assessment Body issuing the ETA: ITeC

ITeC has been designated according to Article 29 of Regulation (EU) No 305/2011 and is member of EOTA (European Organisation for Technical Assessment)

<b>Trade name of the construction product</b>	<b>VSP Anchor</b>
<b>Product family to which the construction product belongs</b>	33 – Fixings
<b>Manufacturer</b>	<b>Vorpa S.r.l.</b> Via San Leo, 5 47838 RICCIONE (RN) Italy
<b>Manufacturing plant(s)</b>	Via dell'Artigianato 10/12 47838 RICCIONE (RN) Italy
<b>This European Technical Assessment contains</b>	11 pages including 7 Annexes which form an integral part of this assessment.
<b>This European Technical Assessment is issued in accordance with Regulation (EU) 305/2011, on the basis of</b>	European Assessment Document 330232-00-0601.
<b>This ETA replaces</b>	ETA 07/0031, with validity from 05.12.2012 to 04.12.2017.

### **General comments**

Translations of this European Technical Assessment in other languages shall fully correspond to the original issued document and should be identified as such.

Communication of this European Technical Assessment, including transmission by electronic means, shall be in full. However, partial reproduction may be made, with the written consent of issuing Technical Assessment Body. Any partial reproduction has to be identified as such.

## Specific parts of the European Technical Assessment

### 1 Technical description of the product

This ETA is applicable to the following product: Vorpa heavy duty VSP anchor in the range of M6 to M16 made of steel, with one expansion cone, which is placed into a drilled hole and anchored by torque-controlled expansion.

The illustration, dimensions and data for the installation of the product are given in Annexes A1 to A4.

### 2 Specification of the intended use(s) in accordance with the applicable European Assessment Document (hereinafter EAD)

The performances given in Section 3 are only valid if the anchor is used in compliance with the specifications and conditions given in Annex B.

The provisions made in this ETA are based on an assumed working life of at least 50 years for VSP anchor. These provisions are based upon the current state of the art and the available knowledge and experience.

The indications given on the working life cannot be interpreted as a guarantee given by the producer, but are to be regarded only as a means for choosing the right products in relation to the expected economically reasonable working life of the works.

### 3 Performance of the product and reference to the methods used for its assessment

Performance of VSP anchor related to the basic requirements for construction works (hereinafter BWR) were determined according to EAD 330232-00-0601.

#### 3.1 Mechanical resistance and stability (BWR 1)

Essential characteristic	Performance
Characteristic resistance to tension load (static and quasi-static loading)	See Annex C1
Characteristic resistance to shear load (static and quasi-static loading)	See Annex C2

#### 3.2 Safety in case of fire (BWR 2)

Essential characteristic	Performance
Reaction to fire	Class A1

#### 4 Assessment and verification of constancy of performance (hereinafter AVCP) system applied, with reference to its legal base

According to the Decision 96/582/EC, of the European Commission<sup>1</sup>, the system of AVCP (see EC delegated regulation (EU) No 568/2014 amending Annex V to Regulation (EU) 305/2011) given in the following table applies.

Product	Intended use	Level or class	System
Metal anchors for use in concrete	For fixing and/or supporting to concrete, structural elements (which contributes to the stability of the works) or heavy units	-	1

#### 5 Technical details necessary for the implementation of the AVCP system, as provided for in the applicable EAD

All the necessary technical details for the implementation of the AVCP system are laid down in the *Control Plan* deposited with the ITeC<sup>2</sup>, with which the factory production control shall be in accordance.

Any change in the manufacturing procedure which may affect the properties of the product shall be notified and the necessary type-testing revised according to the *Control Plan*.

Issued in Barcelona on 22 November 2017

by the Catalonia Institute of Construction Technology.



Ferran Bermejo Nualart  
Technical Director, ITeC

<sup>1</sup> Official Journal of the European Communities L 254 of 08.10.1996

<sup>2</sup> The *Control Plan* is a confidential part of the ETA and is only handed over to the notified certification body involved in the assessment and verification of constancy of performance.

### Scheme of the anchor in use

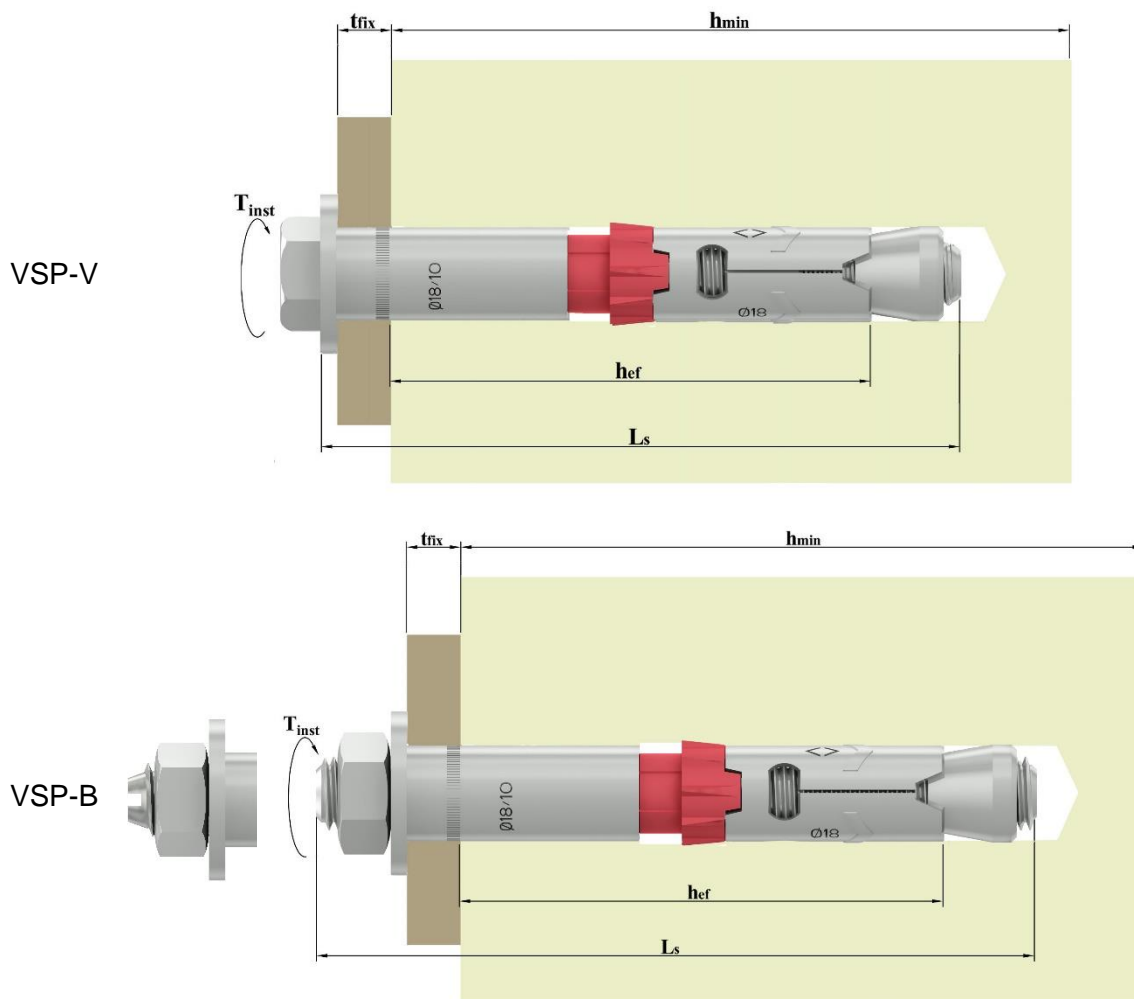

- hef: Effective anchorage depth
- h<sub>min</sub>: Minimum thickness of the concrete member
- L<sub>s</sub>: Screw length
- t<sub>fix</sub>: Thickness of fixture
- T<sub>inst</sub>: Torque of installation

<p><b>VSP torque-controlled expansion anchor</b></p>	<p><b>Annex A1</b></p>
<p><b>Product description</b> Installation condition</p>	

### Components and marking system

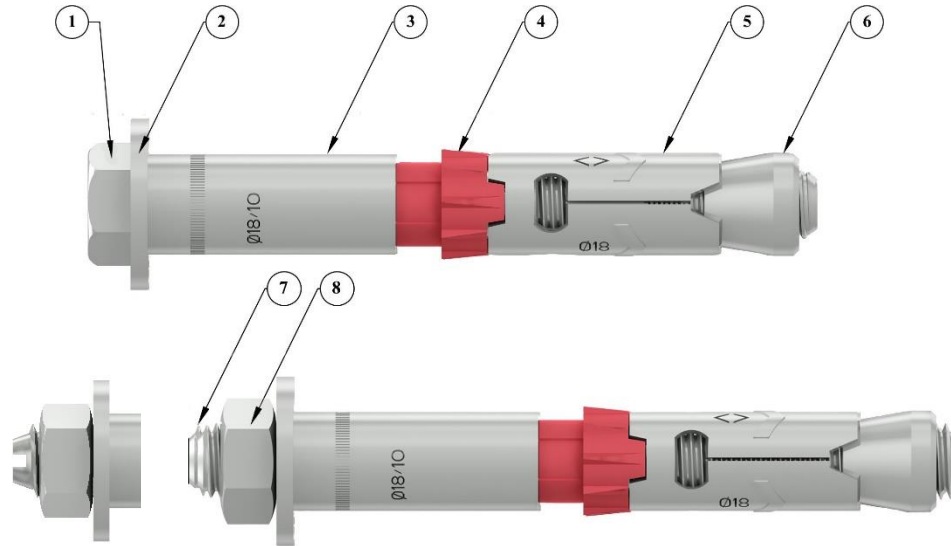

**COMPONENTS:**

- 1 – Hexagonal head bolt
- 2 – Washer
- 3 – Extension
- 4 – Compensation ring
- 5 – Expander
- 6 – Conical nut
- 7 – Threaded rod
- 8 – Hexagonal nut

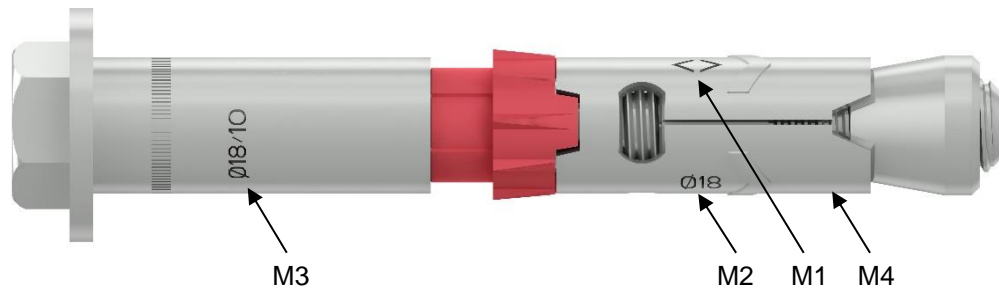

**MARKING:**

- M1 – Manufacturer and product logo ( < > )
- M2 – Hole diameter (mm) (i.e. Ø18)
- M3 – Hole diameter (mm) / T<sub>fix</sub> (N·m) (i.e. Ø18/10)
- M4 – Thread diameter (mm) (i.e. M12) rear

<p><b>VSP torque-controlled expansion anchor</b></p>	<p><b>Annex A2</b></p>
<p><b>Product description</b> Components and marking</p>	

**Table 1: Materials**

Number	Component	Manufacturing process	Standard	Steel class / grade	Coating
1	Hexagonal head bolt	Cold forming	ISO 898-1	8.8	UNI EN ISO 2081 Fe/Zn 5 zincplated
2	Washer	Cold forming	UNI EN 10111	-	UNI EN ISO 2081 Fe/Zn 5 zincplated
3	Extension	Cut	UNI EN ISO 8494 UNI EN 10025	-	UNI EN ISO 2081 Fe/Zn 5 zincplated
4	Compensation ring	Hot pull	-	-	-
5	Expander	Cold forming M6, M8, M10 and M12	UNI EN 10111	-	UNI EN ISO 2081 Fe/Zn 5 zincplated
		Machined M16	UNI EN 10087	-	
6	Conical nut	Cold forming M6, M8, M10 and M12	UNI EN 10111	DD11 - DD13	UNI EN ISO 2081 Fe/Zn 5 zincplated
		Machined M16	UNI EN 10087	-	
7	Threaded rod <sup>(1)</sup>	Cut	-	8.8	UNI EN ISO 2081 Fe/Zn 5 zincplated
8	Hexagonal nut	Cold forming	UNI EN ISO 4032	8.8	UNI EN ISO 2081 Fe/Zn 5 zincplated

<sup>(1)</sup> The steel ETG 25 is used for the threaded rod.

**VSP torque-controlled expansion anchor**

**Product description**  
Materials

**Annex A3**

**Table 2: Anchor dimensions, steel properties and minimum distances**

Dimensions and data			Metrics				
			M6/10	M8/12	M10/15	M12/18	M16/24
Diameter	d	[mm]	6	8	10	12	16
Length	L	[mm]	70 - 80 110	80 - 90 120	90 - 100 130	110 - 125 150 - 200	140 - 165
Effective length	$h_{ef}$	[mm]	49	59	67	88	99
Fixture thickness	$T_{fix}$	[mm]	10 - 20 50	10 - 20 50	10 - 20 50	10 - 25 50 - 100	25 - 50
VSP-V Screw body steel	Section	[mm <sup>2</sup> ]	26,88	48,77	76,97	109,36	196,00
	Threaded section	[mm <sup>2</sup> ]	20,1	36,6	58,0	84,3	157,0
	$f_{uk}$	[N/mm <sup>2</sup> ]	800	800	800	800	800
	$f_{yk}$	[N/mm <sup>2</sup> ]	640	640	640	640	640
	$f_{u,test}$	[N/mm <sup>2</sup> ]	1.186,3	1.116,2	809,1	808,2	810,2
	$f_{y,test}$	[N/mm <sup>2</sup> ]	1.114,6	1.070,2	732	756,5	698,8
VSP-B Threaded rod body steel	Section	[mm <sup>2</sup> ]	21,7	39,6	62,9	90,8	167,4
	Threaded section	[mm <sup>2</sup> ]	20,1	36,6	58,0	84,3	157,0
	$f_{uk}$	[N/mm <sup>2</sup> ]	800	800	800	800	800
	$f_{yk}$	[N/mm <sup>2</sup> ]	660	660	660	660	660
	$f_{u,test}$	[N/mm <sup>2</sup> ]	866	866	866	865	866
	$f_{y,test}$	[N/mm <sup>2</sup> ]	798	796	798	796	798
Minimum distances	$s_{min}$	[mm]	100	120	140	480	240
	$c_{min}$	[mm]	70	80	90	110	130
	$h_{min}$	[mm]	100	125	135	190	220

**Table 3: Parameters of installation**

Anchor	$D_{nom}$ Nominal diameter of the drill bit	$h_{min}$ Minimum thickness of the concrete slab	$h_1$ Depth of the drilled hole	$h_{nom}$ Setting depth	$T_s$ Tightening torque	$d_f$ Diameter of the hole in the fixture
	[mm]	[mm]	[mm]	[mm]	[N·m]	[mm]
M6	10	100	75	60	10	12
M8	12	125	85	70	25	14
M10	15	135	95	79	50	17
M12	18	190	120	102	80	20
M16	24	220	130	113	150	26

**VSP torque-controlled expansion anchor**

**Product description**

Anchor dimensions and parameters of installation

**Annex A4**



### Specifications of intended use

**Anchorage subject to:**

- Static or quasi-static loads.

**Base materials:**

- Reinforced or unreinforced normal weight concrete of strength classes C20/25 to C50/60 according to EN 206.
- Non-cracked concrete.

**Use conditions (Environmental conditions):**

- Structures subject to dry indoor conditions, indoor with temporary condensation.

**Design:**

- Anchorages are designed under the responsibility of an engineer experienced in anchorages and concrete work.
- Anchorages are designed in accordance with the EN 1992-4 and TR 055: Design of fastenings based on EAD 330232-00-0601.
- Verifiable calculation notes and drawings are prepared taking account of the loads to be anchored. The position of the anchor is indicated on the design drawings.

**Installation:**

- Anchor installation carried out by appropriately qualified personnel and under the supervision of the person responsible for technical matters of the site.
- Use of the anchor only as supplied by the manufacturer without exchanging the components of an anchor.
- Anchor installation in accordance with the manufacturer's specifications and drawings and using the appropriate tools.
- Ensure that the strength class of the concrete in which the anchor is to be placed is in the range given and is not lower than that of the concrete to which the characteristic loads apply.
- Check of concrete being well compacted and (e.g. without significant voids) clear the hole of drilling dust.
- Effective anchorage depth, edge distances and spacing not less than the specified values without minus tolerances.
- In case of aborted hole, drilling of new hole at a minimum distance of twice the depth of the aborted hole, or smaller distance provided the aborted drill hole is filled with high strength mortar and no shear or oblique tension loads in the direction of aborted hole.

<b>VSP torque-controlled expansion anchor</b>	<b>Annex B</b>
<b>Intended use</b> Specifications	

**Table 4: Characteristic resistance to tension load (static and quasi-static loading)**

Characteristics			Metrics				
			M6/10	M8/12	M10/15	M12/18	M16/24
Steel failure	$N_{Rk,s}$	[kN]	11	20	49	64	126
	$E_s$	[N/mm <sup>2</sup> ]	210.000				
	$\gamma_{ms}$		1,5				
	$N_{Rk,s}/\gamma_{ms}$	[kN]	7,5	13,6	32,5	42,9	83,7
Pull-out failure	$N_{Rk,p}$ C20/C25	[kN]	9	12	16	25	40
	$h_{ef}$	-	49	59	67	88	99
	$\gamma_{inst}$	-	1,0	1,2	1,2	1,0	1,2
	$\gamma_{MP}$	-	1,80	2,16	2,16	1,80	2,16
	$N_{Rk,p}/\gamma_{MP}$	[kN]	5,0	5,6	7,4	13,9	18,5
	$\psi_c$ C30	-	1,22				
	$\psi_c$ C40	-	1,41				
Concrete edge failure	$K_{cr,N}$	-	7,7				
	$K_{ucr,N}$	-	11,0				
Critical distances	$s_{cr,N}$	[mm]	210	250	290	390	420
	$c_{cr,N}$	[mm]	140	200	220	260	280
	$s_{cr,sp}$	[mm]	210	250	290	390	420
	$c_{cr,sp}$	[mm]	140	200	220	260	280
$\gamma_{MC} = \gamma_{MP} = \gamma_{M,sp}$							
$\gamma_{MC} = \gamma_c * \gamma_1 * \gamma_{inst}$ with: $\gamma_c = 1,5$ & $\gamma_1 = 1,2$							

**VSP torque-controlled expansion anchor****Performance of the product**

Characteristic resistance and displacement under tension load

**Annex C1**

**Table 5: Characteristic resistance to shear load (static and quasi-static loading)**

Characteristics			Metrics				
			M6/10	M8/12	M10/15	M12/18	M16/24
Steel failure without lever arm	$V_{Rk,s}^0$	[kN]	8,0	16,8	25	33,7	62,8
	$\gamma_{ms}$		1,25				
	$V_{Rk,s}^0/\gamma_{ms}$	[kN]	6,4	13,4	20,0	27,0	50,2
Steel failure with lever arm	$M_{Rk,s}^0$	[N·m]	12	30	60	105	266
	$\gamma_{ms}$		1,25				
	$M_{Rk,s}^0/\gamma_{ms}$	[N·m]	9,6	24,0	48,0	84,0	212,8
Pry-out failure	$K_8$	-	1	1	2	2	2
	$\gamma_{Mc}$	-	1,8	2,16	2,16	1,8	2,16
Concrete edge failure	$h_{ef}$	[mm]	49	59	67	88	99
	$l_f$	[mm]	49	59	67	88	99
	$\gamma_{Mc}$	-	1,8	2,16	2,16	1,8	2,16
Tensile load	N	[kN]	3,6	4,0	5,3	9,9	13,2
Displacements	$\delta_{N0}$	[mm]	0,06	0,07	0,11	0,17	0,23
	$\delta_{N\infty}$	[mm]	-	-	1,47	-	-
Shear load	V	[kN]	4,6	9,6	14,3	19,3	35,9
Displacements	$\delta_{V0}$	[mm]	2,3	3,7	3,8	4,0	4,1
	$\delta_{V\infty}$	[mm]	3,5	5,6	5,7	6,0	6,2
$\gamma_{Mc} = \gamma_{MP} = \gamma_{M,sp}$							
$\gamma_{Mc} = \gamma_c * \gamma_1 * \gamma_{inst}$ with: $\gamma_c = 1,5$ & $\gamma_1 = 1,2$							

**VSP torque-controlled expansion anchor****Performance of the product**

Characteristic resistance and displacement under shear load

**Annex C2**