



## European Technical Assessment

**ETA 16/0891**  
of 30.07.2019



### General part

#### Technical Assessment Body issuing the ETA: ITeC

ITeC has been designated according to Article 29 of Regulation (EU) No 305/2011 and is member of EOTA (European Organisation for Technical Assessment).

**Trade name of the construction product**

**AF Collar**

**Product family to which the construction product belongs**

Fire stopping and fire sealing products.  
Penetration seals.

**Manufacturer**

**AF SYSTEMS SRL**  
Via Edward Jenner 41-43  
IT-26837 Mulazzano  
Italy

**Manufacturing plant(s)**

According to Annex N kept by ITeC.

**This European Technical Assessment contains**

32 pages including 2 Annexes which form an integral part of this assessment

and

Annex N, which contains confidential information and is not included in the European Technical Assessment when that assessment is publicly available.

**This European Technical Assessment is issued in accordance with Regulation (EU) 305/2011, on the basis of**

European Assessment Document EAD 350454-00-1104.

**This version replaces**

ETA 16/0891, issued on 21.12.2016.

**General comments**

Translations of this European Technical Assessment in other languages shall fully correspond to the original issued document.

Communication of this European Technical Assessment, including transmission by electronic means, shall be in full (excepted the confidential Annex(es)).

## Specific parts of the European Technical Assessment

### 1 Technical description of the product

AF Collar is a services closure device used as fire pipe penetration seal, consisting of a fire protective inlay made of intumescent material contained in a stainless steel housing.

AF Collar is supplied in different sizes and designs depending on the external diameter of the service to be protected. The detailed technical specification of AF Collar and the description of the installation procedure are given in Annex A.

Assembled penetration seals require additional components as described in Annex B. These components cannot be CE marked based on this ETA.

### 2 Specification of the intended use(s) in accordance with the applicable EAD

AF Collar is used to reinstate the resistance to fire performance of flexible or rigid wall and rigid floor constructions where they are penetrated by services (combustible pipes, insulated metal pipes, multilayer composite pipes and cables). The detailed specification of the services that may be protected with AF Collar are given in Annex B.

The specific elements of construction where the AF Collar may be used to provide a penetration seal in, are as follows unless otherwise specified in Annex B:

- Flexible walls: Walls with a minimum thickness of 120 mm, which comprise timber or steel studs lined on both faces with minimum two layers of 12,5 mm thick 'Type F' or 'Type DF' gypsum plasterboards according to EN 520<sup>1</sup>. In timber stud walls, no part of the penetration shall be closer than 100 mm to a stud, the cavity must be closed between the penetration seal and the stud and minimum 100 mm of insulation of reaction to fire class A1 or A2, according to EN 13501-1, is provided within the cavity between the penetration seal and the stud.
- Rigid walls: Concrete or masonry walls with a minimum thickness of 120 mm and a minimum density of 500 kg/m<sup>3</sup>.
- Rigid floors: Light weight concrete or other type of rigid floors with a minimum thickness of 150 mm and a minimum density of 550 kg/m<sup>3</sup>.

The constructive element where the collars are installed must be classified in accordance with EN 13501-2<sup>2</sup> for the required fire resistance period.

---

<sup>1</sup> EN 520 Gypsum plasterboards. Definitions, requirements and test methods.

<sup>2</sup> EN 13501-2 Fire classification of construction products and building elements. Part 2: Classification using data from fire resistance tests, excluding ventilation services.

AF Collar is intended for environmental conditions as defined for use category Type Y<sub>2,(-20/70)°C</sub> according to EAD 350454-00-1104: intended for semi-exposed use at temperatures below 0°C, but with no exposure to rain nor UV. Type Y<sub>2,(-20/70)°C</sub> includes lower use categories (i.e. Type Z<sub>1</sub> and Type Z<sub>2</sub>).

The provisions made in this ETA are based on a working life of AF Collar of at least 10 years, provided that the conditions laid down in the manufacturer's instructions for the installation, use and maintenance are met. These provisions are based upon the current state of the art and the available knowledge and experience.

The indications given as to the working life of the product cannot be interpreted as a guarantee but are regarded only as a means for choosing the appropriate products in relation to the expected economically reasonable working life of the works.

### 3 Performance of the product and reference to the methods used for its assessment

#### 3.1 Performance of the product

The assessment of AF Collar has been performed in accordance with EAD 350454-00-1104 for *Penetration Seals (September 2017)*.

**Table 1:** Performance of the product.

Product: AF Collar		Intended use: Fire penetration seal	
Basic requirement	Essential characteristic		Performance
BWR 2 Safety in case of fire	Reaction to fire	Inlay material	E
		Steel housing	A1
	Resistance to fire	See Annex B	
BWR 4 Safety and accessibility in use	Durability		Type Y <sub>2,(-20/70)°C</sub>

The rest of characteristics included in EAD 350454-00-1104 have not been assessed in this ETA.

## 3.2 Methods used for the assessment

### 3.2.1 Reaction to fire

The performance of the inlay material of AF Collar has been tested according to EN ISO 11925-2<sup>3</sup> and determined according to EN 13501-1<sup>4</sup> and Regulation (EU) 2016/364.

The collar housing made of stainless steel has a class A1 according to Decision 96/603/EC and Decision 2000/605/EC.

### 3.2.2 Fire resistance

Tested and assessed according to EN 1366-3<sup>5</sup>, the fire resistance classification has been determined according to EN 13501-2 and is given in Annex B.

### 3.2.3 Durability

AF Collar has been tested and assessed for the environmental use category Type Y<sub>2, (-20/70)°C</sub> in accordance with section 2.2.9 of EAD 350454-00-1104 and the EOTA Technical Report 024<sup>6</sup>, section 4.2.5, table 4.1.

Stainless steel in accordance with EN 10088-1<sup>7</sup> is intended for use category Type Y<sub>2, (-20/70)°C</sub>.

## 4 Assessment and verification of constancy of performance (AVCP) system applied, with reference to its legal base

According to the Decision 1999/454/EC of the European Commission, the system of AVCP (see EC delegated Regulation (EU) No 568/2014 amending Annex V to Regulation (EU) 305/2011) given in the following table applies.

**Table 2:** AVCP System.

Product(s)	Intended use(s)	Level(s) or class(es)	System(s)
Fire stopping and fire sealing products	For fire compartmentation and/or fire protection or fire performance	Any	1

<sup>3</sup> EN ISO 11925-2 Reaction to fire tests. Ignitability of products subjected to direct impingement of flame. Part 2: Single-flame source test.

<sup>4</sup> EN 13501-1 Fire classification of construction products and building elements. Part 1: Classification using data from reaction to fire tests.

<sup>5</sup> EN 1366-3 Fire resistance tests for service installations. Part 3: Penetration seals (2009).

<sup>6</sup> TR 024 Characterisation, Aspects of Durability and Factory Production Control for Reactive Materials, Components and Products, Edition July 2009.

<sup>7</sup> EN 10088-1 Stainless steels. Part 1: List of stainless steels.

## 5 Technical details necessary for the implementation of the AVCP system, as foreseen in the applicable EAD

All the necessary technical details for the implementation of the AVCP system are laid down in the *Control Plan* deposited with the ITeC and agreed in accordance with EAD 350454-00-1104, section 3.

The *Control Plan* is a confidential part of the ETA and only handed over to the notified product certification body involved in the assessment and verification of constancy of performance.

The factory production control operated by the manufacturer shall be in accordance with the above mentioned *Control Plan*.

Issued in Barcelona on 30 July 2019  
by the Catalonia Institute of Construction Technology.



Ferran Bermejo Nualart  
Technical Director, ITeC

## ANNEX A. Description of the product and installation process

### A.1. AF Collar components

AF Collar is available in different sizes and designs in accordance with figures A.1 and A.2 and table A.2. For AF Collar 30 to AF Collar 315 and AF Collar 3 30 to AF Collar 3 110, the steel housing which contains the intumescent part is provided with a hinge and toggle latch for collar closing, as well as flanges for fixing to the constructive element.

AF Collar 400 to AF Collar 600 have a boxed shape with the intumescent part contained in 2 lateral boxes, including flanges for fixing to the constructive element. The other two lateral parts to close the collar are composed by steel sheet (the four pieces are fixed together using M8 bolts and nuts).

AF Collar is made of the components described in table A.1 and sizes in accordance with table A.2. Three different thicknesses of the steel sheet housing are used. The intumescent strip is manufactured at a nominal thickness of 4 mm and the total intumescent thickness of every collar size (b in table A.2) is achieved by adding the required number of intumescent strip layers. The intumescent strip is manufactured at different widths according to the specified collar length (H in table A.2).

**Table A.1:** Components of AF Collar.

Part	Material	Dimensions	
Housing	Stainless steel AISI 430 (1.4016) According to EN 10088-1	Sheet thickness	0,6 mm (AF Collar 30 to AF Collar 160 and AF Collar 3 30 to AF Collar 3 110)
			0,8 mm (AF Collar 200 to AF Collar 315)
			2,0 mm (AF Collar 400 to AF Collar 600)
		Other dimensions according to table A.2 and figures A.1 to A.2	
Inlay strip	Intumescent material	Thickness	4 mm (all sizes of AF Collar and AF Collar 3)
			30 mm (AF Collar 3 30 to AF Collar 3 110)
		Width	50 mm (AF Collar 30 to AF Collar 110)
			70 mm (AF Collar 125 to AF Collar 160)
			100 mm (AF Collar 200 and AF Collar 250)
			2 x 100 mm (AF Collar 315 and AF Collar 600)
100 mm + 50 mm (AF Collar 400 and AF Collar 500)			

### A.2. AF Collar dimensions

AF Collar is manufactured in different sizes depending on the service to be protected. The corresponding resistance to fire performance is given in Annex B, depending on the construction elements penetrated by the service and the penetration characteristics.

The AF Collar types covered by this ETA are given in table A.2.

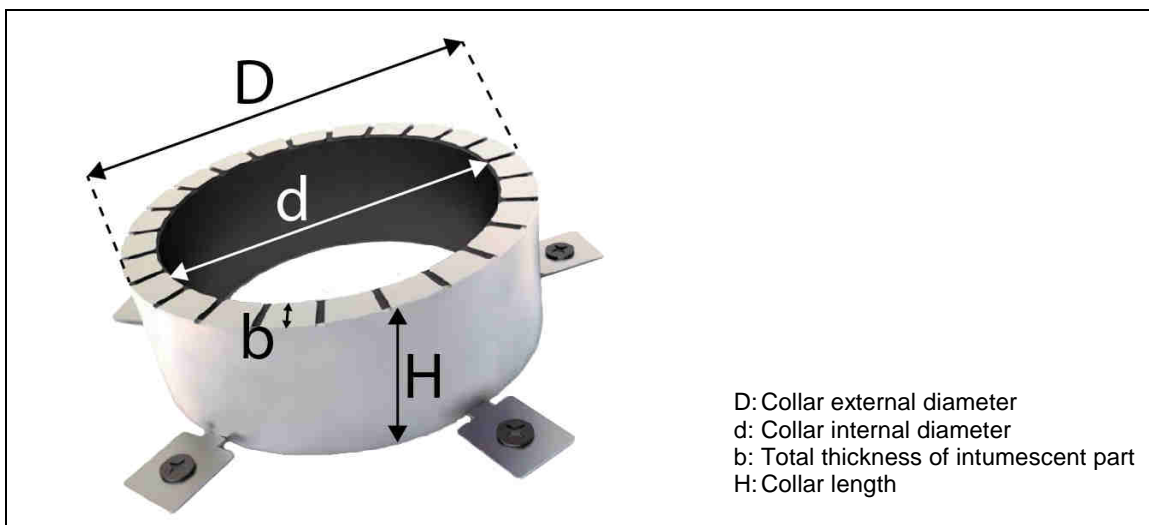

**Figure A.1:** Dimensions of AF Collar and AF Collar 3.

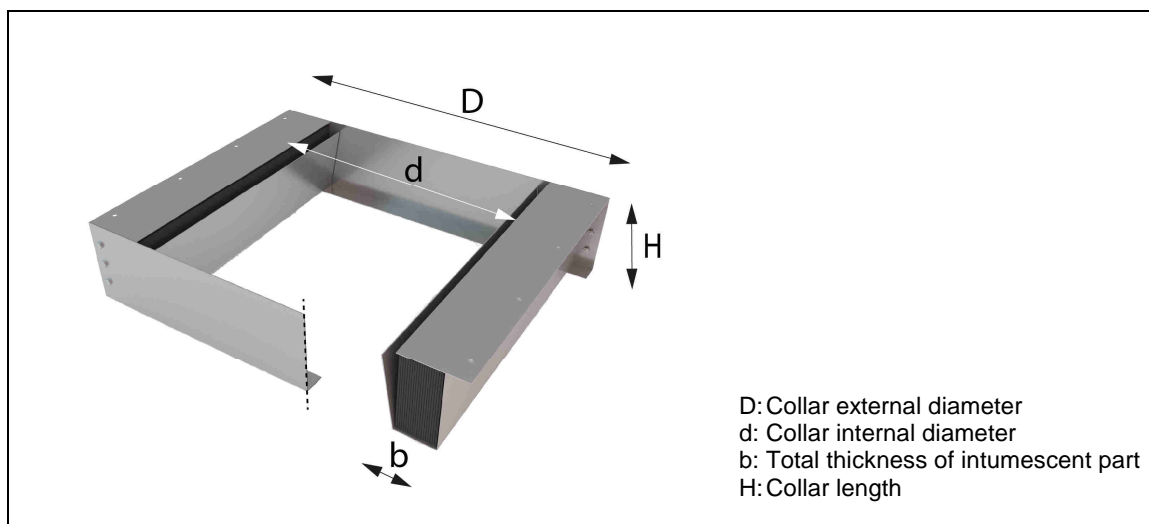

**Figure A.2:** AF Collar 400 to AF Collar 600.

**Table A.2:** Dimensions of AF Collar.

Type	d (mm)	D (mm)	H (mm)	b (mm)	Nº of strip layers	Nº of fixing flanges
AF Collar 30	35	52	50	8	2	4
AF Collar 3 30	35	52	30	8	2	4
AF Collar 40	45	62	50	8	2	4
AF Collar 3 40	45	62	30	8	2	4
AF Collar 50	55	72	50	8	2	4
AF Collar 3 50	55	72	30	8	2	4
AF Collar 63	68	85	50	8	2	4
AF Collar 3 63	68	85	30	8	2	4
AF Collar 80	85	102	50	8	2	4



**Table A.2:** Dimensions of AF Collar.

Type	d (mm)	D (mm)	H (mm)	b (mm)	N° of strip layers	N° of fixing flanges
AF Collar 3 80	85	118	30	16	4	4
AF Collar 90	95	112	50	8	2	4
AF Collar 3 90	95	128	30	16	4	4
AF Collar 100	105	122	50	8	2	4
AF Collar 3 100	105	138	30	16	4	4
AF Collar 110	115	132	50	8	2	4
AF Collar 3 110	115	148	30	16	4	4
AF Collar 125	130	155	70	12	3	5
AF Collar 140	145	170	70	12	3	5
AF Collar 160	165	190	70	12	3	5
AF Collar 180	185	227	100	20	5	5
AF Collar 200	210	252	100	20	5	5
AF Collar 250	260	302	100	20	5	5
AF Collar 315	325	375	200	24	6	5
AF Collar 400	420	536	157	56	14	8
AF Collar 500	510	764	157	72	18	8
AF Collar 600	650	946	207	96	24	8

### A.3. AF Collar installation

AF Collar will be installed in accordance with the manufacturer instructions and the provisions established in this section and in the relevant sections of Annex B.

AF Collar 400 to AF Collar 600 shall be fixed to the constructive element depending on the intended use as follows, unless otherwise specified in Annex B:

- In flexible and rigid walls, by means of Ø8 mm steel threaded bars passing the constructive element and held with nuts, with a perforated steel plate of minimum 1 mm thickness placed at the non-exposed side to distribute the load of the nuts.
- In floors, at the bottom side by means of Ø8 mm x 60 mm galvanised steel class 8.8 expansion anchors.

The rest of AF Collar shall be fixed to the constructive element depending on the intended use as follows, unless otherwise specified in Annex B:

- In flexible walls, by means of Ø8 mm x 120 mm galvanised steel screws at the fire exposed side and Ø8 mm x 50 mm galvanised steel screws at the cold side.
- In rigid walls, at both sides by means of Ø8 mm x 60 mm galvanised steel class 8.8 expansion anchors.

- In floors, at the bottom side by means of Ø8 mm x 60 mm galvanised steel class 8.8 expansion anchors.

The number of fixings will be in accordance with table A.2. The number of fixing flanges of the collar housing may be different from the required number of fixings. Fixings will be installed every other flange.

All gaps between penetrations and constructive elements will not be greater than 5 mm and shall be filled in with mortar (floors and rigid walls) or gypsum paste (flexible walls), also spread over the constructive element surface around the collar base.

The minimum distance between services penetrating the wall/floor, as well as the minimum distance between services and the constructive element edge, is 200 mm.

The maximum distance from the constructive element to the adequate service support is 500 mm in case of walls (cold side) and floors (upper side).

The following installation provisions will be noted:

- The installation of the penetration seal will not have an effect on the stability of the adjacent building element, even in the event of fire.
- The structural elements related to the wall/floor in which the penetration seal is incorporated will be designed and fire protected in such a way that no additional mechanical load is imposed on the penetration seal.
- The thermal movements of the pipework will be accommodated in such a way that no resulting load is imposed on the penetration seal.
- The services are fixed to the building element in such a way that no additional mechanical load is imposed on the penetration seal in the event of fire.
- The support of the services is maintained during the required period of resistance to fire.
- Pneumatic dispatch systems, compressed air systems, etc. are switched off in the event of fire.

## **ANNEX B. Resistance to fire performance**

### **B.1. General**

The following intended uses are included in this Annex:

- B.2. Plastic pipes.
  - B.2.1. Plastic pipes passing through a flexible or rigid wall.
  - B.2.2. Plastic pipes passing through a rigid floor.
  - B.2.3. Plastic pipes passing through AF Panel.
  - B.2.4. Inclined plastic pipes passing through a rigid floor.
- B.3. Plastic pipes with acoustic insulation performance.
  - B.3.1. Plastic pipes passing through a flexible or rigid wall.
  - B.3.2. Plastic pipes passing through a rigid floor.
- B.4. Multilayer composite pipes.
  - B.4.1. Multilayer composite pipes passing through a flexible or rigid wall.
  - B.4.2. Multilayer composite pipes passing through a rigid wall.
- B.5. Insulated metal pipes.
  - B.5.1. Insulated metal pipes passing through a flexible or rigid wall.
  - B.5.2. Insulated metal pipes passing through a rigid floor.
- B.6. Cables passing through a flexible or rigid wall.

## B.2. Plastic pipes

Regarding the material specification of those services included in this Annex B.2, pipes will be made from:

- PVC-U according to EN 1329-1<sup>8</sup>, EN 1453-1<sup>9</sup> and EN ISO 1452-1<sup>10</sup>.
- PVC-C according to EN 1566-1<sup>11</sup>.
- PP according to EN 1451-1<sup>12</sup>.
- HDPE according to EN 1519-1<sup>13</sup> or EN 12666-1<sup>14</sup>.
- PE according to EN 12201-2<sup>15</sup>, EN 1519-1 and EN 12666-1.
- ABS according to EN 1455-1<sup>16</sup>.
- SAN+PVC according to EN 1565-1<sup>17</sup>.

Regarding the pipe end configuration, according to section 2.2.2 of EAD 350454-00-1104 the following field of application applies:

- a classification given for a configuration U/U is also valid for any other pipe end configuration: C/U, U/C and C/C.
- a classification given for a configuration U/C is also valid for a pipe end configuration C/U and C/C.
- a classification given for a configuration C/U is also valid for a pipe end configuration C/C.
- a classification given for a configuration C/C is only valid for a pipe end configuration C/C.

Definition of the pipe end configuration is given in section 6.3.4 of EN 1366-3.

Regarding the pipe diameter and pipe wall thickness, the rules for the field of direct application of the test results given in EN 1366-3 can be applied, i.e. resistance to fire classification given in this section B.2 is valid between the pipe diameters and pipe wall thicknesses as given in the tables, provided that AF Collar is installed in accordance with Annex A.

- 
- <sup>8</sup> EN 1329-1      Plastics piping systems for soil and waste discharge (low and high temperature) within the building structure. Unplasticized poly(vinyl chloride) (PVC-U). Part 1: Specifications for pipes, fittings and the system.
- <sup>9</sup> EN 1453-1      Plastics piping systems with structured wall-pipes for soil and waste discharge (low and high temperature) inside buildings. Unplasticized poly(vinyl chloride) (PVC-U). Part 1: Specifications for pipes and the system.
- <sup>10</sup> EN ISO 1452-1      Plastics piping systems for water supply and for buried and above-ground drainage and sewerage under pressure. Unplasticized poly(vinyl chloride) (PVC-U). Part 1: General (ISO 1452-1:2009).
- <sup>11</sup> EN 1566-1      Plastics piping systems for soil and waste discharge (low and high temperature) within the building structure. Chlorinated poly(vinyl chloride) (PVC-C). Part 1: Specifications for pipes, fittings and the system.
- <sup>12</sup> EN 1451-1      Plastics piping systems for soil and waste discharge (low and high temperature) within the building structure. Polypropylene (PP). Part 1: Specifications for pipes, fittings and the system.
- <sup>13</sup> EN 1519-1      Plastics piping systems for soil and waste discharge (low and high temperature) within the building structure. Polyethylene (PE). Part 1: Specifications for pipes, fittings and the system.
- <sup>14</sup> EN 12666-1      Plastics piping systems for non-pressure underground drainage and sewerage. Polyethylene (PE). Part 1: Specifications for pipes, fittings and the system.
- <sup>15</sup> EN 12201-2      Plastics piping systems for water supply, and for drainage and sewerage under pressure. Polyethylene (PE). Part 2: Pipes.
- <sup>16</sup> EN 1455-1      Plastics piping systems for soil and waste discharge (low and high temperature) within the building structure. Acrylonitrile-butadiene-styrene (ABS). Part 1: Requirements for pipes, fittings and the system.
- <sup>17</sup> EN 1565-1      Plastics piping systems for soil and waste discharge (low and high temperature) within the building structure. Styrene copolymer blends (SAN+PVC). Part 1: Specifications for pipes, fittings and the system.

### B.2.1. Plastic pipes passing through a flexible or rigid wall

The flexible or rigid wall shall meet the specification given in section 2 of this ETA.

The relevant size and design of AF Collar will be installed, in accordance with Annex A and the pipe diameter specified in tables B.2.1.1 to B.2.1.6, at both sides of the wall as shown in figure B.2.1.1, except for AF Collar 400 and AF Collar 500 which are only installed at the exposed side of the wall as shown in figure B.2.1.2.

The resistance to fire of the sealed combustible pipes is given in tables B.2.1.1 to B.2.1.6.

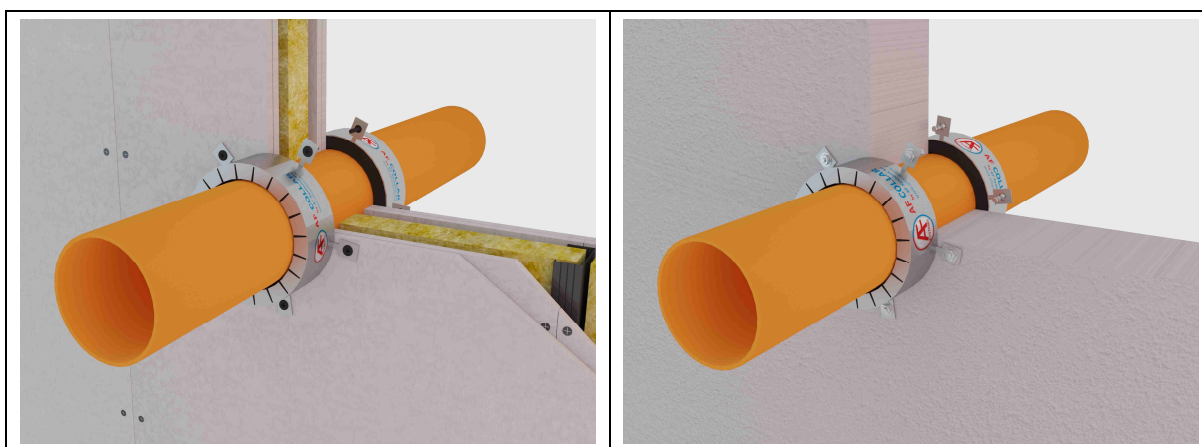

**Figure B.2.1.1:** Example of plastic pipe penetration seal in a flexible or rigid wall.

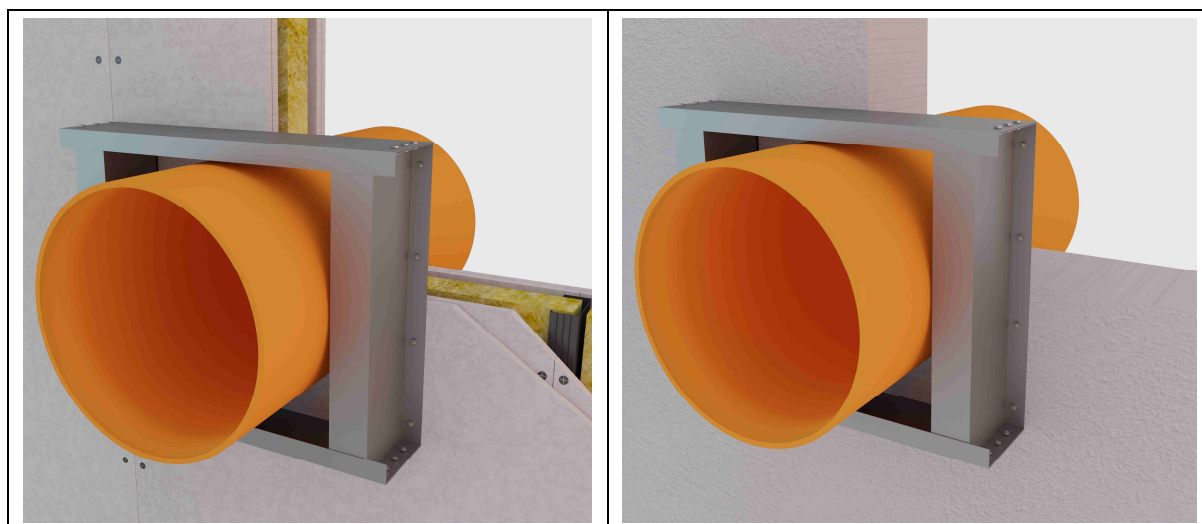

**Figure B.2.1.2:** Example of plastic pipe penetration seal in a flexible wall (AF Collar 400) or rigid wall (AF Collar 400 and AF Collar 500).

**Table B.2.1.1:** AF Collar, PVC pipes.

External pipe diameter [Ø] (mm)	Pipe wall thickness [t]		Resistance to fire class
	t <sub>min</sub> (mm)	t <sub>max</sub> (mm)	
≤ 110	3,2	8,1	EI 120 U/U EI 180 U/C <sup>18</sup>
110 < Ø ≤ 160	3,2	9,5 11,0	EI 120 U/U EI 180 U/C <sup>18</sup>
160 < Ø ≤ 250	6,2	18,4	EI 120 U/C
315	7,7	23,2	EI 90 U/C <sup>19</sup>
400	9,8	9,8	EI 120 U/C
500	14,6	14,6	EI 120 U/C <sup>18</sup>

**Table B.2.1.2:** AF Collar 3, PVC pipes.

External pipe diameter [Ø] (mm)	Pipe wall thickness [t]		Resistance to fire class
	t <sub>min</sub> (mm)	t <sub>max</sub> (mm)	
≤ 63	3,0	5,8	EI 120 U/U
63 < Ø ≤ 110	3,2	8,1	EI 120 U/U

**Table B.2.1.3:** AF Collar, PP pipes.

External pipe diameter [Ø] (mm)	Pipe wall thickness [t]		Resistance to fire class
	t <sub>min</sub> (mm)	t <sub>max</sub> (mm)	
≤ 110	2,7	15,1	EI 120 U/U
110 < Ø ≤ 160	3,9	14,6	EI 120 U/C
160 < Ø ≤ 250	7,7	16,0	EI 120 U/C

**Table B.2.1.4:** AF Collar 3, PP pipes.

External pipe diameter [Ø] (mm)	Pipe wall thickness [t]		Resistance to fire class
	t <sub>min</sub> (mm)	t <sub>max</sub> (mm)	
≤ 63	1,8	10,5	EI 120 U/C <sup>20</sup>
63 < Ø ≤ 110	2,7	15,1	EI 120 U/C <sup>21</sup>

<sup>18</sup> Resistance to fire classification only valid for rigid walls of minimum thickness 150 mm.<sup>19</sup> Resistance to fire EI 120 U/C for pipe wall thickness 7,7mm.<sup>20</sup> For a pipe with a wall thickness of 1,8 mm, the resistance to fire class is EI 120 U/U regarding the pipe end configuration.<sup>21</sup> For a pipe with a wall thickness of 2,7 mm, the resistance to fire class is EI 120 U/U regarding the pipe end configuration.

**Table B.2.1.5:** AF Collar, HDPE, PE, ABS and SAN+PVC pipes.

External pipe diameter [Ø] (mm)	Pipe wall thickness [t]		Resistance to fire class
	t <sub>min</sub> (mm)	t <sub>max</sub> (mm)	
≤ 110	4,2	12,3	EI 120 U/U
110 < Ø ≤ 160	6,2	16,0	EI 120 U/C
160 < Ø ≤ 250	7,7	22,7	EI 120 U/C
315	9,7	28,6	EI 120 U/C

**Table B.2.1.6:** AF Collar 3, HDPE, PE, ABS and SAN+PVC pipes.

External pipe diameter [Ø] (mm)	Pipe wall thickness [t]		Resistance to fire class
	t <sub>min</sub> (mm)	t <sub>max</sub> (mm)	
≤ 63	3,0	8,6	EI 120 U/U
63 < Ø ≤ 110	4,2	15,1	EI 120 U/C <sup>22</sup>

## B.2.2. Plastic pipes passing through a rigid floor

The rigid floor shall meet the specification given in section 2 of this ETA.

The relevant size and design of AF Collar will be installed, in accordance with Annex A and the pipe diameter specified in tables B.2.2.1 to B.2.2.6, at the bottom side of the floor as shown in figures B.2.2.1 and B.2.2.2.

The resistance to fire of the sealed combustible pipes is given in tables B.2.2.1 to B.2.2.6.

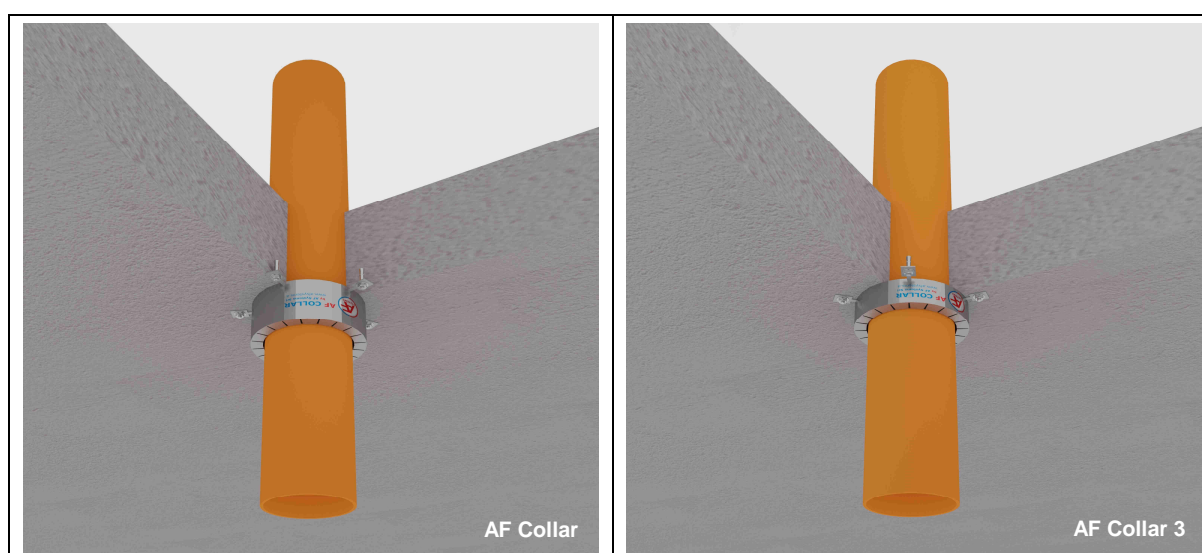

**Figure B.2.2.1:** Example of plastic pipe penetration seal in a rigid floor.

<sup>22</sup> For a pipe with a wall thickness of 4,2 mm, the resistance to fire class is EI 120 U/U regarding the pipe end configuration.

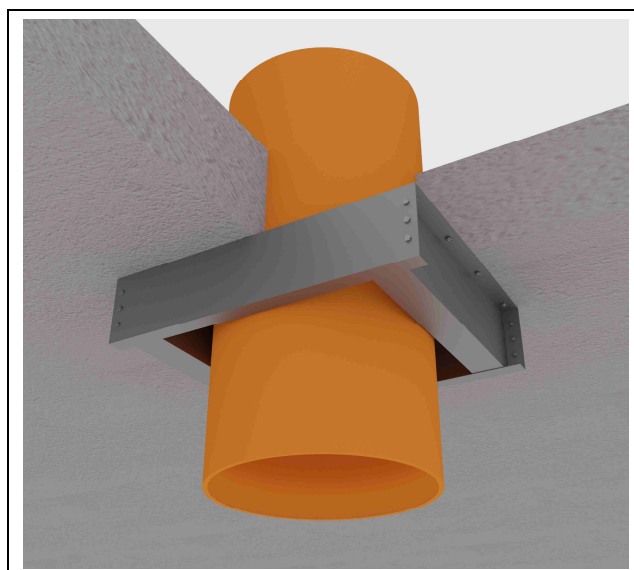

**Figure B.2.1.2:** Example of plastic pipe penetration seal (AF Collar 400 and AF Collar 600) in a rigid floor.

**Table B.2.2.1:** AF Collar, PVC pipes.

External pipe diameter [Ø] (mm)	Pipe wall thickness [t]		Resistance to fire class
	t <sub>min</sub> (mm)	t <sub>max</sub> (mm)	
≤ 110	3,2	8,1	EI 180 U/U
110 < Ø ≤ 160	3,2	11,8	EI 180 U/C
160 < Ø ≤ 250	6,2	18,4	EI 180 U/C <sup>23</sup>
315	7,7	23,2	EI 120 U/C <sup>24</sup>
400	6,0	6,0	EI 180 U/C <sup>23,25</sup>
600	11,0	11,0	EI 120 U/C <sup>23</sup>

**Table B.2.2.2:** AF Collar 3, PVC pipes.

External pipe diameter [Ø] (mm)	Pipe wall thickness [t]		Resistance to fire class
	t <sub>min</sub> (mm)	t <sub>max</sub> (mm)	
≤ 63	3,0	5,8	EI 180 U/U <sup>23</sup>
63 < Ø ≤ 110	3,2	8,1	EI 180 U/U <sup>23</sup>

<sup>23</sup> Performance valid for a rigid floor with a minimum density of 1600 kg/m<sup>3</sup>.

<sup>24</sup> Resistance to fire EI 180 U/C for pipe wall thickness 23,2 mm.

<sup>25</sup> Resistance to fire class valid for a rigid floor of minimum thickness 200 mm. The joint and/or gap between the pipe and floor will be filled in with AF SEAL W acrylic sealant at the upper side.



**Table B.2.2.3:** AF Collar, PP pipes.

External pipe diameter [Ø] (mm)	Pipe wall thickness [t]		Resistance to fire class
	t <sub>min</sub> (mm)	t <sub>max</sub> (mm)	
≤ 110	2,7	2,7	EI 180 U/U
	15,1	15,1	EI 120 U/U
110 < Ø ≤ 160	3,9	14,6	EI 180 U/C
160 < Ø ≤ 250	8,8	22,7	EI 180 U/C <sup>26</sup>

**Table B.2.2.4:** AF Collar 3, PP pipes.

External pipe diameter [Ø] (mm)	Pipe wall thickness [t]		Resistance to fire class
	t <sub>min</sub> (mm)	t <sub>max</sub> (mm)	
≤ 63	1,8	10,5	EI 180 U/C <sup>23,27</sup>
63 < Ø ≤ 110	2,7	15,1	EI 180 U/C <sup>23,28</sup>

**Table B.2.2.5:** AF Collar, HDPE, PE, ABS and SAN+PVC pipes.

External pipe diameter [Ø] (mm)	Pipe wall thickness [t]		Resistance to fire class
	t <sub>min</sub> (mm)	t <sub>max</sub> (mm)	
≤ 110	4,2	15,1	EI 180 U/U
110 < Ø ≤ 160	6,2	21,9	EI 180 U/C
160 < Ø ≤ 250	8,2	22,7	EI 180 U/C <sup>29</sup>
315	9,0	28,6	EI 180 U/C

**Table B.2.2.6:** AF Collar 3, HDPE, PE, ABS and SAN+PVC pipes.

External pipe diameter [Ø] (mm)	Pipe wall thickness [t]		Resistance to fire class
	t <sub>min</sub> (mm)	t <sub>max</sub> (mm)	
≤ 63	3,0	8,6	EI 180 U/C <sup>23,30</sup>
63 < Ø ≤ 110	4,2	15,1	EI 180 U/C <sup>23,31</sup>

<sup>26</sup> For a pipe with a wall thickness of 8,8 mm, the performance is valid for rigid floors with a minimum density of 1600 kg/m<sup>3</sup>.

<sup>27</sup> For a pipe with a wall thickness of 1,8 mm, the resistance to fire class is EI 180 U/U regarding the pipe end configuration.

<sup>28</sup> For a pipe with a wall thickness of 2,7 mm, the resistance to fire class is EI 180 U/U regarding the pipe end configuration.

<sup>29</sup> For a pipe with a wall thickness of 8,2 mm, the performance is valid for rigid floors with a minimum density of 1600 kg/m<sup>3</sup>.

<sup>30</sup> For a pipe with a wall thickness of 3,0 mm, the resistance to fire class is EI 180 U/U regarding the pipe end configuration.

<sup>31</sup> For a pipe with a wall thickness of 4,2 mm, the resistance to fire class is EI 180 U/U regarding the pipe end configuration.

### B.2.3. Plastic pipes passing through AF PANEL

#### B.2.3.1. Resistance to fire performance

The resistance to fire performance given in section B.2.1 and section B.2.2 for plastic pipes up to a pipe diameter of 250 mm, protected with AF Collar according to table A.2 of this ETA, are also valid when the pipe penetrates a double layer of AF PANEL, as described in B.2.3.2, which shuts an opening in the constructive element meeting the specification given in section 2 of this ETA (rigid floors with a minimum density of 1600 kg/m<sup>3</sup>).

#### B.2.3.2. Description of AF PANEL

AF PANEL is a rock wool panel of density 150 kg/m<sup>3</sup> and thickness 50 mm, coated on both faces with 1 mm thickness of the acrylic ablative coating AF SEAL T (AF PANEL total thickness of 52 mm).

Two layers of AF PANEL are installed levelled to the constructive element surfaces as shown in figures B.2.3.1 and B.2.3.2. AF PANEL is installed tightly fitted by pressure to the constructive element without mechanical fixing (in the case of flexible walls, a frame of steel C-profiles of (50 x 69 x 0,6) mm is installed around the opening). AF SEAL W acrylic sealant shall be applied at the joint between the plastic pipe and AF PANEL at both sides of the wall, as well as at the perimeter of AF PANEL in contact with the constructive element.

In the case of walls, the maximum size of the opening shut with AF PANEL is 1750 mm x 1000 mm, with a permitted increase up to either 25 % in height or 25 % in width or 25 % in area in accordance with table A.3 in EN 15882-3<sup>32</sup>. Vertical and horizontal joints can be installed within the panel area. If a blank seal (opening shut with AF PANEL without passing services) is installed, no splices are allowed.

In the case of floors, the maximum size of the opening shut with AF PANEL is 900 mm x 750 mm. Vertical and horizontal joints can be installed within the panel area. If a blank seal (opening shut with AF PANEL without passing services) is installed, no splices are allowed.

More than one plastic pipe can be installed passing through the panels provided that total amount of cross sections of pipes does not exceed the 10 % of the opening area, the distance between pipes is higher than 210 mm and the distance from any pipe to the opening edges is higher than 100 mm.

#### B.2.3.3. Installation of AF Collar in walls with an opening shut by AF PANEL

AF Collar is fixed at both sides of the wall with steel wires of minimum diameter 1 mm from the collar flanges to the wall, where the wires are fixed by Ø3,5 mm x 55 mm self-tapping steel screws in flexible walls (fixed to the metal C-profiles frame around the opening) and by expansion anchors Ø8 mm x 60 mm in rigid walls. The minimum number of wires to fix the collar shall be in accordance with the number of fixings given in table A.2.

AF SEAL W acrylic sealant is applied at an approximate dry thickness of 2 mm over the fire exposed surface of AF PANEL, completely covering the steel wires and their fixing to the constructive element.

---

<sup>32</sup> EN 15882-3 Extended applications of results from fire resistance tests for service installations. Part 3: Penetration seals.

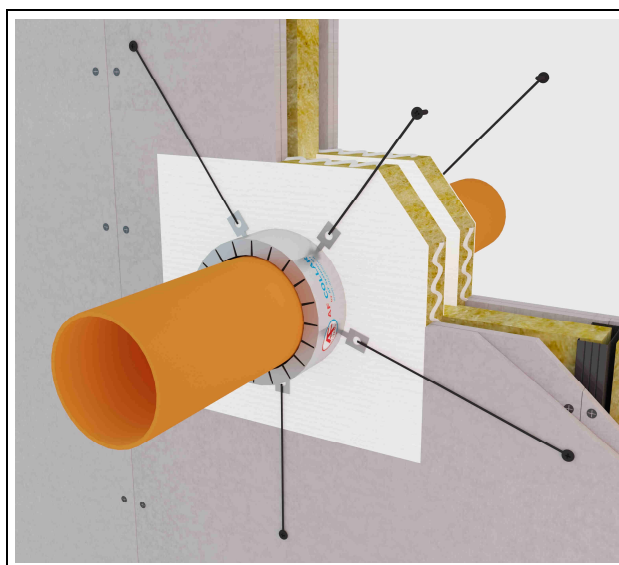
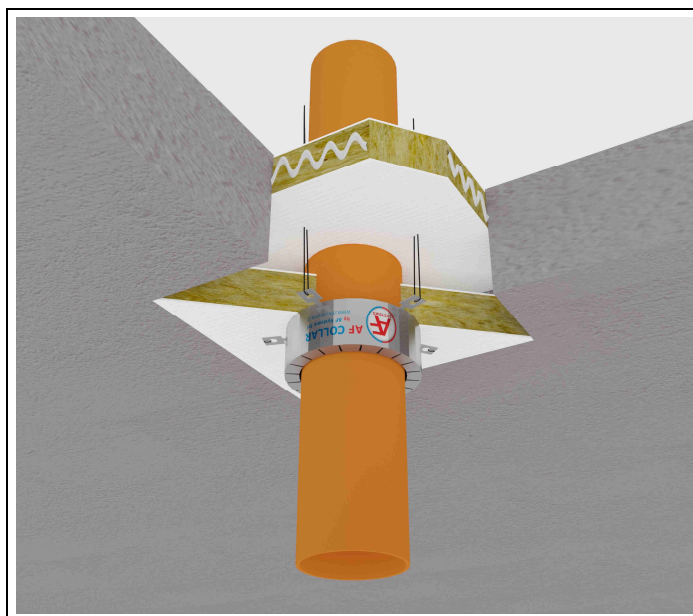

**Figure B.2.3.1:** Example of AF Collar fixed with steel wires in walls.

#### B.2.3.4. Installation of AF Collar in floors with an opening shut by AF PANEL

AF Collar is held at the bottom side of the floor with steel wires of minimum diameter 1 mm from all the collar flanges, passing through the double layer of AF PANEL and fixed to a protected supporting structure at the upper side of the floor.

AF SEAL W acrylic sealant is applied at an approximate dry thickness of 2 mm over the fire exposed surface of AF PANEL, completely covering the steel wires.



**Figure B.2.3.2** Example of AF Collar fixed with steel wires in floors.

### B.2.3.5. Installation of AF Collar embedded in the AF PANEL in walls

The flexible or rigid wall shall meet the specification given in section 2 of this ETA.

The relevant size of AF Collar will be installed in accordance with Annex A and the pipe diameter specified in tables B.2.3.1 to B.2.3.2. AF Collar will be installed integrated in a double layer of AF Panel at the exposed side of the wall as shown in figure B.2.3.3.

The resistance to fire of the sealed combustible pipes is given in tables B.2.3.1 to B.2.3.2.

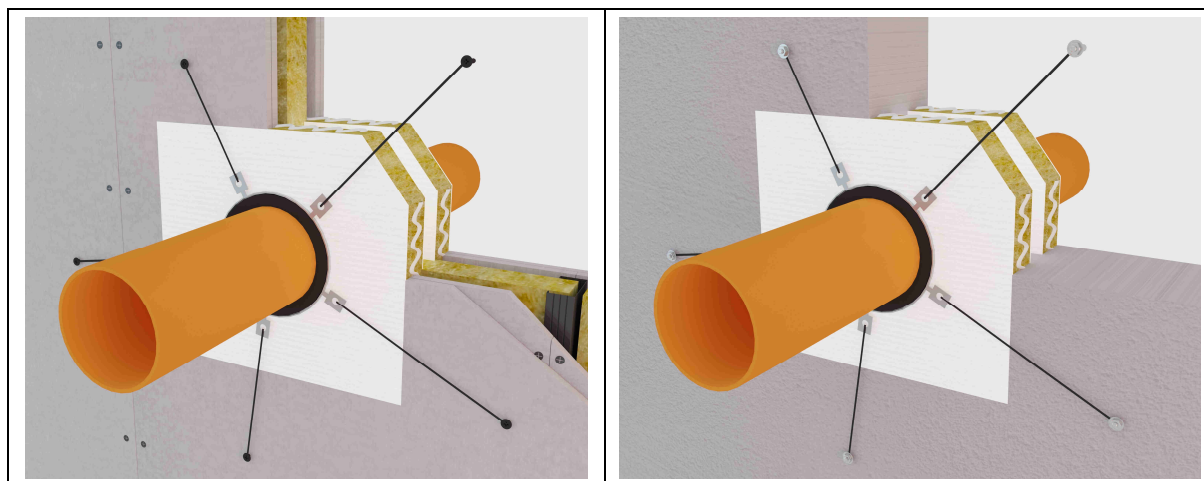

**Figure B.2.3.3:** Example of AF Collar embedded in the AF PANEL in a flexible or rigid wall.

The maximum size of the AF PANEL will be 450 mm x 450 mm. No splice can be included. Only one penetration is allowed, placed in the centre of the AF PANEL.

AF Collar is incorporated between the pipe and AF PANEL and held in every flange with steel wires of minimum diameter 1 mm from the collar flanges to the wall, where the wires are fixed by Ø3,5 mm x 55 mm self-tapping steel screws in flexible walls (fixed to the metal C-profiles frame around the opening) and by expansion anchors Ø8 mm x 60 mm in rigid walls. AF SEAL W acrylic sealant is applied at an approximate dry thickness of 2 mm over the fire exposed surface of AF PANEL, completely covering the steel wires and their fixing to the constructive element.

For pipe closure devices positioned within the building element, when the overall thickness of such an element is greater than the minimum specified (120 mm), the length of the collar will be increased accordingly and kept levelled at the wall surface.

**Table B.2.3.1:** PVC pipes.

External pipe diameter Ø (mm)	Pipe wall thickness (mm)	Resistance to fire class
≤ 110	3,2	EI 120 U/U

**Table B.2.3.2:** PP pipes.

External pipe diameter Ø (mm)	Pipe wall thickness (mm)	Resistance to fire class
≤ 110	2,7	EI 120 U/U
110 < Ø ≤ 160	3,9	EI 120 U/C

In the case of a rigid wall according to the specification given in section 2 of this ETA with a minimum thickness of 150 mm, the resistance to fire of the sealed combustible pipes is given in table B.2.3.3.

The relevant size of AF Collar will be installed in accordance with Annex A and the pipe diameter specified in table B.2.3.3. AF Collar will be installed integrated in a double layer of AF PANEL at the exposed side of the rigid wall as shown in figure B.2.3.3.

The maximum size of the AF PANEL will be 400 mm x 400 mm. No splice can be included. Only one penetration is allowed, placed in the centre of the AF PANEL.

AF Collar is incorporated between the pipe and AF PANEL and held in every flange with steel wires of minimum diameter 1 mm from the collar flanges to the wall, where the wires are fixed by expansion anchors Ø8 mm x 60 mm. AF SEAL W acrylic sealant is applied at an approximate dry thickness of 2 mm over the fire exposed surface of AF PANEL, completely covering the steel wires and their fixing to the constructive element.

For pipe closure devices positioned within the building element, when the overall thickness of such an element is greater than the minimum specified (150 mm), the length of the collar will be increased accordingly and kept levelled at the wall surface.

**Table B.2.3.3:** PP pipes.

External pipe diameter Ø (mm)	Pipe wall thickness (mm)	Resistance to fire class
≤ 110	3,0	EI 180 U/U

The following application of two pipes (one HDPE pipe and one insulated multilayer composite pipe) passing through a double layer of AF PANEL has a resistance to fire as given in table B.2.3.4. The flexible or rigid wall shall meet the specification given in section 2 of this ETA with a minimum thickness of 125 mm.

The relevant size of AF Collar will be installed in accordance with Annex A and the pipe diameter specified in table B.2.3.4. AF Collar will be installed integrated in a double layer of AF Panel at the fire exposed side of the wall as shown in figure B.2.3.4.

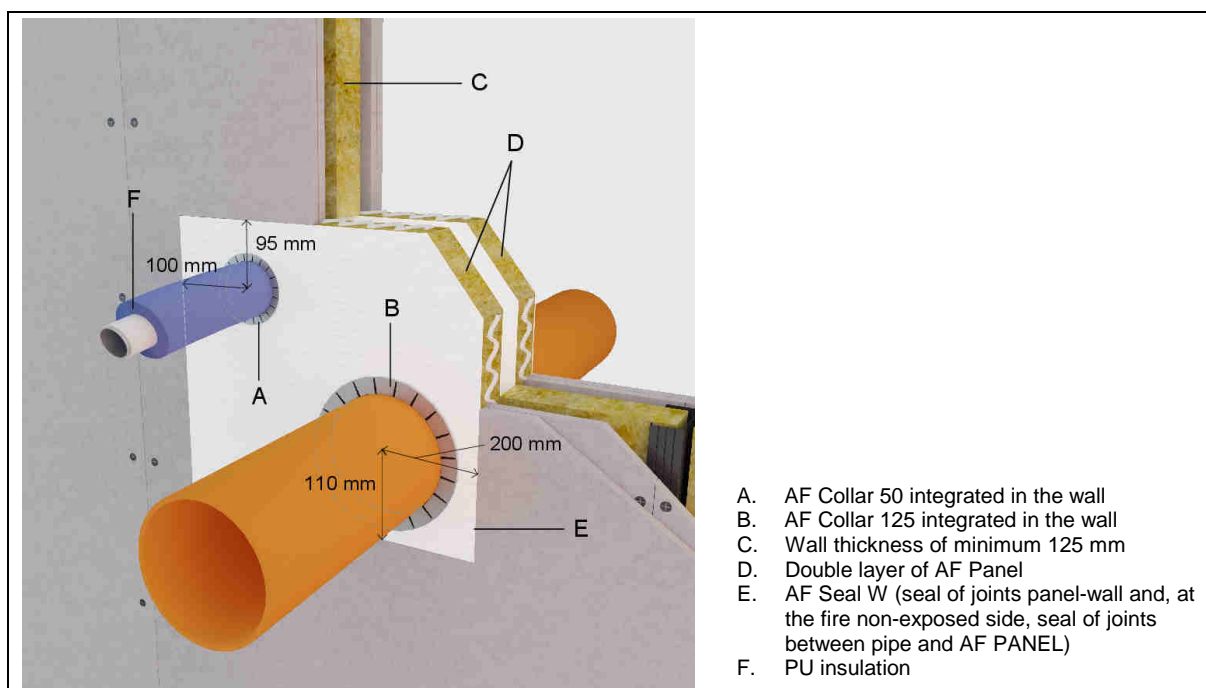

**Figure B.2.3.4:** Double pipe penetration seal in a wall with an opening shut by a double layer of AF PANEL.

The maximum size of the AF PANEL will be 500 mm x 500 mm. No splice can be included. A maximum of two penetrations are allowed. The distance from the centre of the services to the AF PANEL edges shall be as shown in figure B.2.3.4.

AF Collar 125 is incorporated between the HDPE pipe and the AF PANEL and AF Collar 50 is incorporated between the insulated multilayer composite pipe and the AF PANEL. The collars are installed with the fixing flanges in the inner side of the panel. No additional fixing is required.

For pipe closure devices positioned within the building element, when the overall thickness of such an element is greater than the minimum specified (125 mm), the length of the collar will be increased accordingly and kept levelled at the wall surface.

**Table B.2.3.4:** Resistance to fire.

Pipe material	External pipe diameter Ø (mm)	Pipe wall thickness (mm)	Insulation	Resistance to fire class
PE-Xb/Al/HDPE	32	3,0	(1)	EI 120 U/C
HDPE	125	11,5	None	

(1) Continuous insulation of closed cell expanded polyurethane, thickness 10 mm, density 50 kg/m<sup>3</sup> and reaction to fire class D<sub>L</sub>-s3,d0 held with steel wire.

#### B.2.4. Inclined plastic pipes passing through a rigid floor

The rigid floor shall meet the specification given in section 2 of this ETA with a minimum thickness of 200 mm and minimum density of 1600 kg/m<sup>3</sup>.

The relevant size of AF Collar will be installed, in accordance with Annex A<sup>33</sup> and the pipe diameter specified in table B.2.4.1, at the bottom side of the floor as shown in figure B.2.4.1. Pipes are installed at any angle from 90° to 45° in relation to the floor plane. AF Collar will be closely fitted around the inclined pipe. For an external pipe diameter of 110 mm and a pipe angle of 45°, AF Collar 160 will be used (maximum size of AF Collar assessed).

The resistance to fire of the sealed combustible pipes is given in table B.2.4.1.

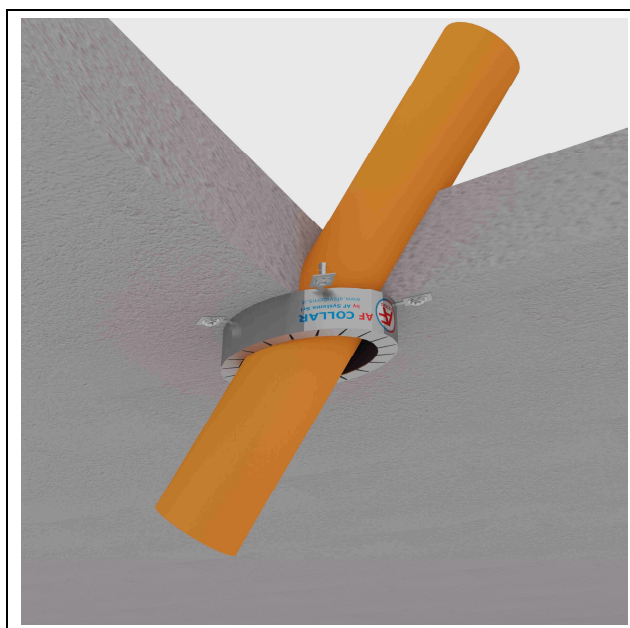

**Figure B.2.4.1:** Example of inclined plastic pipe penetration seal in a floor.

**Table B.2.4.1:** PP pipes.

External pipe diameter [Ø] (mm)	Pipe wall thickness [t]		Resistance to fire class
	t <sub>min</sub> (mm)	t <sub>max</sub> (mm)	
< 110	4,2	14,6	EI 180 U/C

<sup>33</sup> For a pipe wall thickness 4,2 mm, according to table B.2.4.1, the given performance is valid for AF Collar 125, AF Collar 140 and AF Collar 160 with a length (H in table A.2) of 50 mm.



### B.3. Plastic pipes with acoustic insulation performance

#### B.3.1. Plastic pipes passing through a flexible or rigid wall

The flexible or rigid wall shall meet the specification given in section 2 of this ETA.

The relevant size of AF Collar<sup>34</sup> will be installed, in accordance with Annex A and the pipe diameter specified in table B.3.1, at both sides of the wall as shown in figure B.3.1.

The resistance to fire of the sealed combustible pipes with acoustic insulation performance, as listed in table B.3.1 or equivalent, is EI 120 U/C.

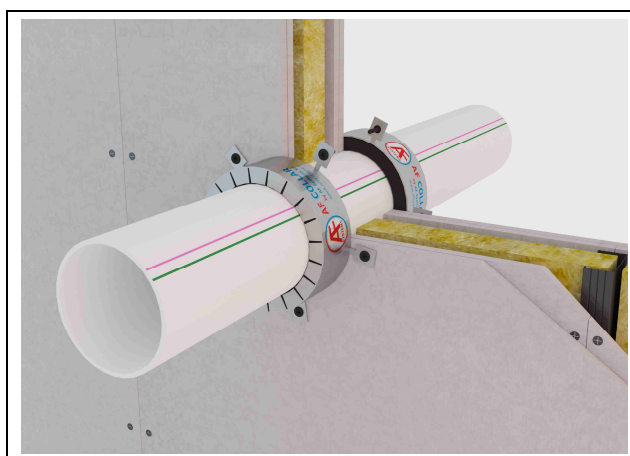

**Figure B.3.1:** Example of acoustic plastic pipe penetration seal in a flexible wall.

**Table B.3.1:** Plastic pipes with acoustic insulation performance.

Type of pipe	External pipe diameter [Ø] (mm)	Pipe wall thickness t (mm)
PVC-U pipe type FRIAPHON of Girpi	≤ 110	6,0
Mineral reinforced PP type SiTech+ of Wavin		3,4
Mineral reinforced PP-MD type RAUPIANO PLUS of Rehau		2,5
Mineral fibers reinforced PE-S2 type Silent-DB20 of Geberit		6,0
Mineral reinforced PP type ASTO of Wavin		6,0
Mineral fibers reinforced PP MX type Silent-Pro of Geberit		6,0

#### B.3.2. Plastic pipes passing through a rigid floor

The rigid floor shall meet the specification given in section 2 of this ETA with a minimum density of 1600 kg/m<sup>3</sup>.

The relevant size of AF Collar<sup>34</sup> will be installed, in accordance with Annex A and the pipe diameter specified in table B.3.2, at bottom side of the floor as shown in figure B.3.2.

<sup>34</sup> AF Collar 3 has not been assessed in this ETA for the plastic pipes with acoustic insulation performance.



The resistance to fire of the sealed combustible pipes with acoustic insulation performance, as listed in table B.3.2 or equivalent, is EI 180 U/C.

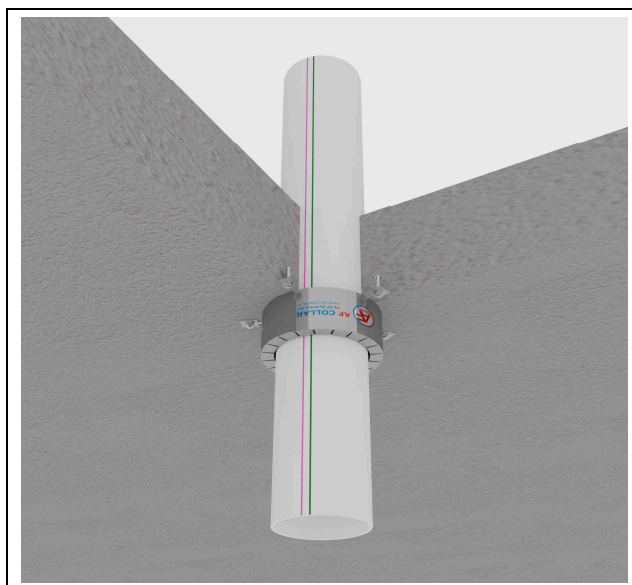

**Figure B.3.2:** Example of acoustic plastic pipe penetration seal in a floor.

**Table B.3.2:** Plastic pipes with acoustic insulation performance.

Type of pipe	External pipe diameter [Ø] (mm)	Pipe wall thickness t (mm)
PVC-U pipe type FRIAPHON of Girpi	≤ 110	6,0
Mineral reinforced PP type SiTech+ of Wavin		3,4
Mineral reinforced PP-MD type RAUPIANO PLUS of Rehau		2,5
Mineral fibers reinforced PE-S2 type Silent-DB20 of Geberit		6,0
Mineral reinforced PP type ASTO of Wavin		5,3
Mineral fibers reinforced PP MX type Silent-Pro of Geberit		4,2

## B.4. Multilayer composite pipes

### B.4.1. Multilayer composite pipes passing through a flexible or rigid wall

The flexible or rigid wall shall meet the specification given in section 2 of this ETA with a minimum thickness of 125 mm.

Two different service installations have been assessed in accordance with tables B.4.1.1 and B.4.1.2.

**Table B.4.1.1:** Bundle of multilayer composite pipes.

Material	External pipe diameter (mm)	Pipe wall thickness (mm)	Insulation	Penetration seal	Description
PE-Xb / Al / HDPE	32	3,0	None	AF Collar 125 according to table A.2	Figure B.4.1.1
	32	3,0	(1)		
	20	2,25	(2)		

(1) Continuous insulation of closed cell expanded polyurethane, thickness 20 mm, density 50 kg/m<sup>3</sup> and reaction to fire class E, held with steel wire.

(2) Continuous insulation of closed cell expanded polyurethane, thickness 10 mm, density 50 kg/m<sup>3</sup> and reaction to fire class E, held with steel wire.

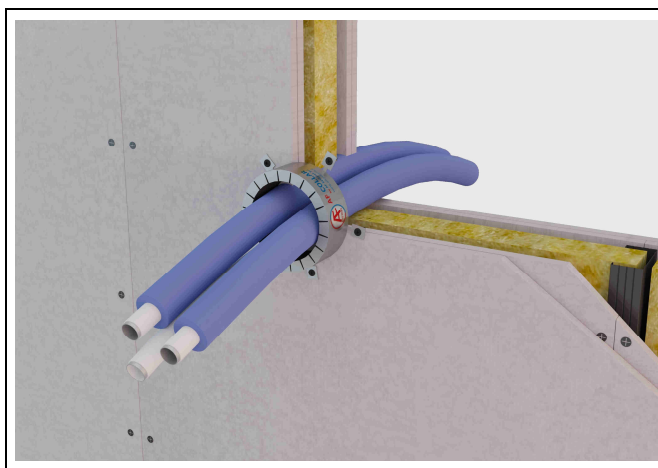

**Figure B.4.1.1:** Example of multilayer composite pipes penetration seal in a flexible wall.

All gaps between the multilayer pipes bundle and the wall, as well as the gaps between the pipes bundle and AF Collar, will be filled with gypsum paste (or mortar in case of rigid walls).

The resistance to fire of the bundle of multilayer composite pipes is EI 120 U/C sealed at the fire exposed side of the wall with AF Collar 125.

**Table B.4.1.2:** Multilayer composite pipe.

Material	External pipe diameter (mm)	Pipe wall thickness (mm)	Insulation	Penetration seal	Description
PE-Xb / Al / HDPE	50	4,5	(1)	AF Collar 80 according to table A.2	Figure B.4.1.2

(1) Continuous insulation of closed cell expanded polyurethane, thickness 20 mm, density 50 kg/m<sup>3</sup> and reaction to fire class E, held with steel wire.

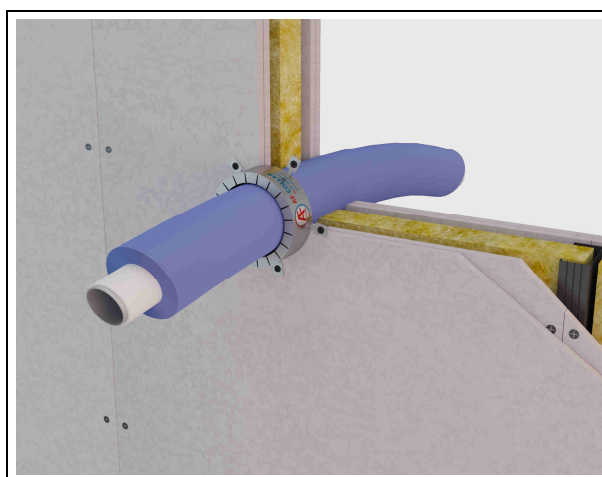
**Figure B.4.1.2:** Example of insulated multilayer composite pipe penetration seal in a flexible wall.

The resistance to fire of the insulated multilayer composite pipe is EI 120 U/C sealed at the fire exposed side of the wall with AF Collar 80.

#### B.4.2. Multilayer composite pipes passing through a rigid wall

The rigid wall shall meet the specification given in section 2 of this ETA with a minimum thickness of 150 mm.

The relevant size of AF Collar<sup>35</sup> will be installed, in accordance with Annex A and the diameter of the service installation as described below, at the fire exposed side of the wall as shown in figure B.4.2.1.

The service installation is formed by a bundle of multilayer composite pipes as specified in table B.4.2.1. Every single pipe is insulated according to table B.4.2.2.

**Table B.4.2.1:** Bundle of multilayer composite pipes.

Material	External pipe diameter (mm)	Pipe wall thickness (mm)	Quantity	Overall installation diameter (mm)
PE-Xb / Al / HDPE	20	3	2	110
	16	2	8	

<sup>35</sup> AF Collar 3 has not been assessed in this ETA for the multilayer composite pipes.

**Table B.4.2.2:** Individual pipe insulation.

Material	Internal insulation diameter (mm)	Insulation thickness (mm)	Density (kg/m <sup>3</sup> )	Reaction to fire
PE	20	7	50	E
	16			

The number of insulated multilayer composite pipes can be reduced, always installed in contact each other, provided that the collar size is adjusted in accordance with table A.2, for AF Collar internal diameter up to 110 mm, to closely fit around the pipes bundle. All gaps between the multilayer pipes bundle and the wall, as well as the gaps between the pipes bundle and AF Collar, will be filled with mortar.

The resistance to fire of the sealed bundle of multilayer composite pipes is EI 180 U/C.

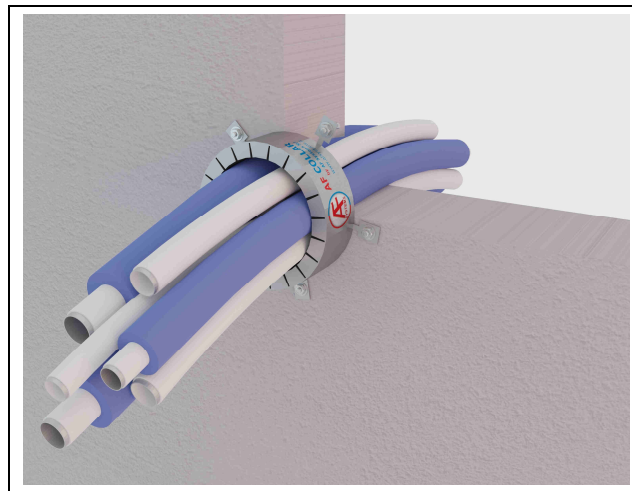

**Figure B.4.2.1:** Example of multilayer composite pipes penetration seal in a rigid wall.

## B.5. Insulated metal pipes

### B.5.1. Insulated metal pipes passing through a flexible or rigid wall

The flexible or rigid wall shall meet the specification given in section 2 of this ETA.

The metal pipe will be made of steel with a minimum melting point of 1450 °C and a maximum thermal conductivity of 52 W/(m·K).

The type of foamed elastomeric insulation material will be as follows:

- Continuous insulation.
- Reaction to fire: from B<sub>L</sub>-s1,d0 to D<sub>L</sub>-s3,d0.
- Maximum thermal conductivity (23 °C):  $\lambda \leq 0,043$  W/(m·K).
- Assessed types of foamed elastomeric insulation material: Armaflex Ultima, Armaflex ACE.

The relevant size of AF Collar<sup>36</sup> will be installed, in accordance with Annex A and the insulated pipe overall diameter specified in table B.5.1, at the fire exposed side of the wall as shown in figure B.5.1.

**Table B.5.1:** Dimensions of the insulated metal pipes.

Metal pipe		Insulation thickness (mm)
External diameter (mm)	Wall thickness (mm)	
20	1	10
	6	
	1	60
	6	
140	1,2	25
	9	
	1,2	60
	9	

The internal surface of the AF Collar must be in contact with the insulation external surface. The rules for the field of direct application of the test results given in EN 1366-3 can be applied regarding the diameter and wall thickness of the metal pipe and the insulation thickness, provided that the collar dimensions are adjusted to closely fit around the insulation and the ratio (insulation thickness / inlay intumescent thickness<sup>37</sup>) is 4 as maximum. This condition (ratio) does not apply to the dimensions given in table B.5.1, only to the intermediate dimensions from interpolation.

The resistance to fire of the sealed insulated metal pipes is EI 120 C/C.

<sup>36</sup> AF Collar 3 has not been assessed in this ETA for the insulated metal pipes.

<sup>37</sup> Inlay intumescent thickness: b in table A.2.

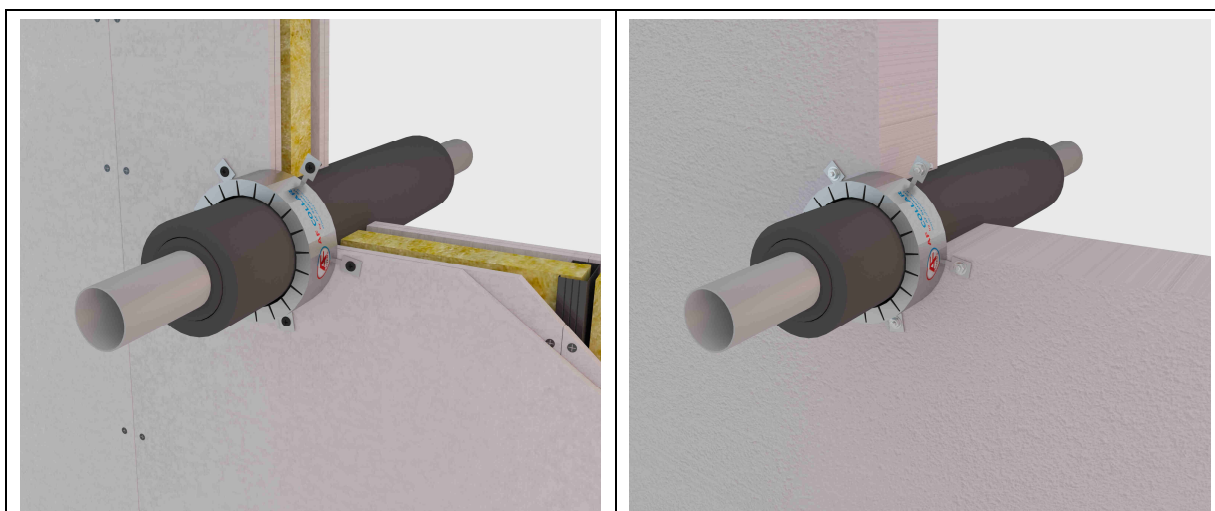

**Figure B.5.1:** Example of insulated metal pipe penetration seal in a flexible or rigid wall.

### B.5.2. Insulated metal pipes passing through a rigid floor

The rigid floor shall meet the specification given in section 2 of this ETA with a minimum density of 1600 kg/m<sup>3</sup>.

The metal pipe will be made of steel with a minimum melting point of 1450 °C and a maximum thermal conductivity of 52 W/(m·K).

The type of foamed elastomeric insulation material will be as follows:

- Continuous insulation.
- Reaction to fire: from B<sub>L</sub>-s1,d0 to D<sub>L</sub>-s3,d0.
- Maximum thermal conductivity (23 °C):  $\lambda \leq 0,043$  W/(m·K).
- Assessed types of foamed elastomeric insulation material: Armaflex Ultima, Armaflex ACE.

The relevant size of AF Collar<sup>38</sup> will be installed, in accordance with Annex A and the insulated pipe overall diameter specified in table B.5.2, at the bottom side of the floor as shown in figure B.5.2.

**Table B.5.2:** Dimensions of the insulated metal pipes.

Metal pipe		Insulation thickness (mm)
External diameter (mm)	Wall thickness (mm)	
20	1	10
	6	
	1	60
	6	
140	1,2	25
	9	
	1,2	60
	9	

<sup>38</sup> AF Collar 3 has not been assessed in this ETA for the insulated metal pipes.

The internal surface of the AF Collar must be in contact with the insulation external surface. The rules for the field of direct application of the test results given in EN 1366-3 can be applied regarding the diameter and wall thickness of the metal pipe and the insulation thickness, provided that the collar dimensions are adjusted to closely fit around the insulation and the ratio (insulation thickness / inlay intumescent thickness<sup>39</sup>) is 4 as maximum. This condition (ratio) does not apply to the dimensions given in table B.5.2, only to the intermediate dimensions from interpolation.

The resistance to fire of the sealed insulated metal pipes is EI 180 C/C.

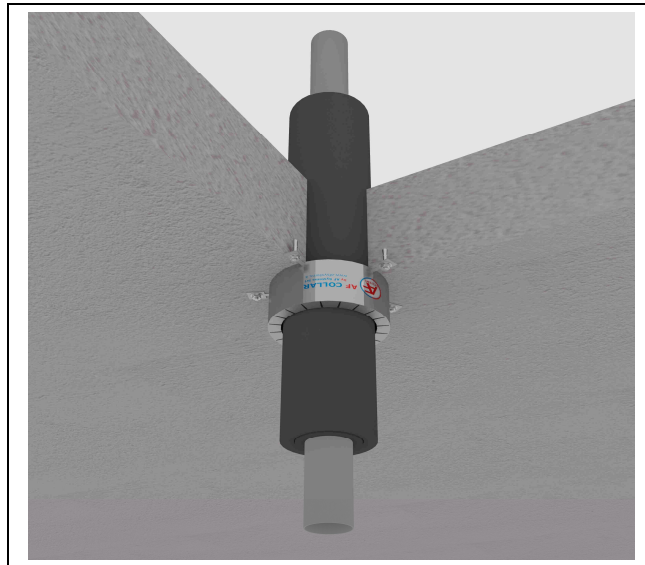

**Figure B.5.2:** Example of insulated metal pipe penetration seal in a floor.

---

<sup>39</sup> Inlay intumescent thickness: b in table A.2.

## B.6. Cables passing through a flexible or rigid wall

The flexible or rigid wall shall meet the specification given in section 2 of this ETA.

The cables shall be of the type “small sheathed cables” (Group 1 according to Annex A of EN 1366-3):

- 10 cables A1 model “5×1,5 mm<sup>2</sup> CI 1 PVC/PVC 600/1000V NYYJ”.
- 10 cables A2 model “5×1,5 mm<sup>2</sup> CI 5 Cu EPR/PCP 450/750V H07RN-F”.
- 10 cables A3 model “5×1,5 mm<sup>2</sup> CI 1 Cu XLPE/LSZH 600/1000V N2XH-J”.
- 2 cables B model “1×95 mm<sup>2</sup> CI 2 PVC/PVC 600/1000V NYY0”.

The cables shall be in accordance with section A.3.1.1<sup>40</sup> of EN 1366-3 with a maximum cable diameter of 21 mm. The cables will be installed kept together.

The relevant size of AF Collar<sup>41</sup> will be installed, at the fire exposed side of the wall as shown in figure B.6.1, in accordance with Annex A up to a maximum overall diameter of the cables bundle of 110 mm (AF Collar 110). The number of cables can be reduced, provided that the collar size is adjusted in accordance with table A.2 (AF Collar 30 to AF Collar 110) to closely fit around the cables bundle.

The resistance to fire of the sealed cables is EI 120.

In the case of a rigid wall of minimum thickness of 150 mm and resistance to fire EI 180, the resistance to fire of the sealed cables as described above is EI 180.

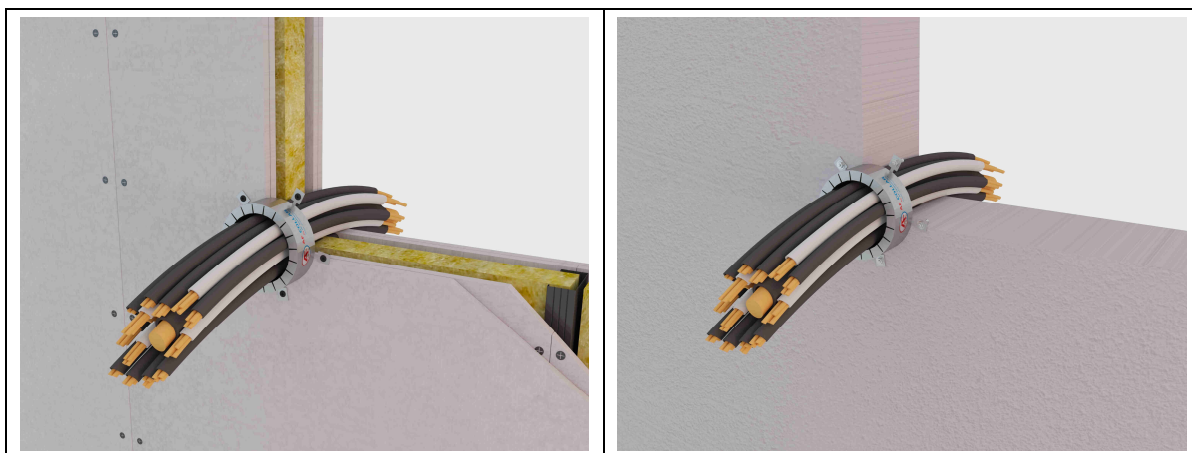

**Figure B.6.1:** Example of small sheathed cables penetration seal in a flexible or rigid wall.

<sup>40</sup> EN 1366-3, A.3.1.1: All cable types currently and commonly used in building practice in Europe except non-sheathed cables (wires), tied bundles and waveguides; optical fibre cables are covered.

<sup>41</sup> AF Collar 3 has not been assessed in this ETA for cables.