



**The Catalonia
Institute of Construction
Technology**

Wellington 19
ES-08018 Barcelona
Tel. +34 93 309 34 04
qualprod@itec.cat
www.itec.cat



European Technical Assessment

ETA 09/0275
of 29.05.2015



General part

Trade name of the construction product	CONLIT[®] 150 P and CONLIT[®] 150 AF
Product family to which the construction product belongs	Fire protective slabs
Manufacturer	ROCKWOOL PENINSULAR SAU Polígono Industrial de Caparroso Ctra. Nacional 121, km 53,5 ES-31380 Caparroso (Navarra) Spain
Manufacturing plant(s)	According to Annex N kept by ITeC
This European Technical Assessment contains	12 pages including 1 Annex which forms an integral part of this assessment and Annex N, which contains confidential information and is not included in the European Technical Assessment when that assessment is publicly available
This European Technical Assessment is issued in accordance with Regulation (EU) 305/2011, on the basis of	ETAG 018, Part 1 edition April 2013 and Part 4 edition December 2011, used as European Assessment Document-EAD
This version replaces	ETA 09/0275, issued on 25.05.2010

General comments

Translations of this European Technical Assessment in other languages shall fully correspond to the original issued document.

Communication of this European Technical Assessment, including transmission by electronic means, shall be in full (excepted the confidential Annex(es)).

Specific parts of the European Technical Assessment

1 Technical description of the product

CONLIT[®] 150 P and CONLIT[®] 150 AF are fire protective slabs made of stone wool impregnated with a synthetic binder. CONLIT[®] 150 P slab has no covering. CONLIT[®] 150 AF slab has, on one face, a decorative covering of aluminium foil, a glass fibre mesh and polyethylene. Both slabs are manufactured by ROCKWOOL PENINSULAR SAU. Dimensions and density of the slabs are given in table 1.

Table 1: Dimensions and density of slabs.

	Nominal value	Tolerance
Density (kg/m ³) at 23°C, 50% RH	180	± 9 %
Length (mm)	1800	± 3
Width (mm)	1200	± 3
Thickness (mm)	20, 25, 30, 40, 50, 60, 70, 80, 90, 100	+3/-1

Assembled systems require additional components as described in Annex 1 of this ETA. Those components are not covered by this ETA and cannot be CE marked on the basis of this ETA.

2 Specification of the intended use(s) in accordance with the applicable EAD

CONLIT[®] 150 P and CONLIT[®] 150 AF are intended for the fire protection of elements or to be used in assemblies as specified in table 2, which also shows the related environmental use conditions.

Table 2: Intended use categories related to the protected element and the environmental conditions.

Fire protection uses		Environmental conditions
ETAG 018-1 reference	Element intended to be protected	ETAG 018-3 reference
Type 4	Load-bearing steel elements	Type Z ₂

This ETA covers assemblies installed in accordance with the provisions given in Annex 1 that specifies the two assessed installation systems: mechanically fixed and bonded.

The environmental use categories are specified in ETAG 018 Part 4, section 2.2.2:

- Type Z₂: internal conditions excluding temperatures below 0°C, with humidity lower than 85% RH.

The provisions made in this ETA are based on a working life of the CONLIT[®] 150 P and CONLIT[®] 150 AF slabs for fire protection of at least 25 years, provided that the conditions laid down in the manufacturer's instructions for the installation, use and maintenance are met. These provisions are based upon the current state of the art and the available knowledge and experience.

The indications given on the working life cannot be interpreted as a guarantee given by the producer or Assessment Body, but are to be regarded only as a means for choosing the appropriate product(s) in relation to the expected economically reasonable working life of the works.

3 Performance of the product and reference to the methods used for its assessment

3.1 Performance of the product

The assessment of CONLIT[®] 150 P and CONLIT[®] 150 AF slabs for the intended use considering the basic requirements for construction works 2, 3 and 4 was performed following the ETAG 018 *Fire Protective Products, Part 1: General (April 2013) and Part 4: Fire protective board, slab and mat products and kits (December 2011)*, used as EAD.

Table 3: Performance of the product.

Product: CONLIT [®] 150 P and CONLIT [®] 150 AF		Intended use: Fire protection of structural steel members	
Basic requirement	Essential characteristic	Performance	
BWR 2 Safety in case of fire	Reaction to fire	A1	
	Resistance to fire	See Annex 1	
BWR 3 Hygiene, health and the environment	Release of dangerous substances	No dangerous substances (see 3.2.3)	
BWR 4 Safety and accessibility in use	Flexural strength	CONLIT [®] 150 P	150 kPa
		CONLIT [®] 150 AF	245 kPa
	Dimensional stability	≤ 1 %	
General aspects relating to the performance of the product	Perpendicular tensile strength	CONLIT [®] 150 P	37 kPa
		CONLIT [®] 150 AF	28 kPa
	Parallel tensile strength	CONLIT [®] 150 P	32 kPa
		CONLIT [®] 150 AF	92 kPa
	Compressive strength (σ_{10})	CONLIT [®] 150 P	25 kPa
		CONLIT [®] 150 AF	28 kPa
Durability	Type Z ₂		

3.2 Methods used for the assessment

3.2.1 Reaction to fire

The performance of the CONLIT[®] 150 P and CONLIT[®] 150 AF slabs has been determined according to EN 13501-1.

CONLIT[®] 150 P has been tested according to EN ISO 1182 and EN ISO 1716. CONLIT[®] 150 AF has additionally been tested according to EN 13823.

3.2.2 Fire resistance

The resistance to fire performance, according to ENV 13381-4 and EN 13501-2, of assemblies using the fire protective slabs CONLIT[®] 150 P and CONLIT[®] 150 AF is presented in Annex 1.

3.2.3 Release of dangerous substances

According to the manufacturer's declaration, the specification of CONLIT[®] 150 P and CONLIT[®] 150 AF has been compared with the dangerous substances listed on EOTA Technical Report 034¹ and with the *Indicative list of regulated dangerous substances possibly associated with construction products under the CPD, DS 041/051 Rev.12, 22 March 2012* of the EC Experts Group to verify that the slabs do not contain such substances, with the exception of formaldehyde and manmade mineral wool fibres as indicated below.

- Formaldehyde: content < 0,0105 mg/m³ (manufacturer's declared value, calculated from slab composition)
- Mineral wool fibres meet the requirements given in Note Q of the Regulation (EC) 1272/2008 and are therefore not potentially carcinogenic²

In addition to the specific clauses relating to dangerous substances contained in this ETA, there may be other requirements applicable to the products falling within its scope. In order to meet the provisions of the EU Construction Products Regulation, these requirements need also to be complied with, when and where they apply.

3.2.4 Flexural strength

The minimum bending strength of CONLIT[®] 150 P and CONLIT[®] 150 AF has been determined according to EN 12089, method B.

3.2.5 Dimensional stability

The slabs CONLIT[®] 150 P and CONLIT[®] 150 AF have been tested according to EN 1604 and are dimensionally stable according to EN 13162 ($\leq 1\%$).

3.2.6 General aspects relating to the performance of the product

In addition to the essential characteristics related to BWR 4, the following mechanical characteristics have been determined:

- Minimum perpendicular tensile strength, according to EN 1607.
- Minimum parallel tensile strength, according to EN 1608 (slabs comply with EN 13162).
- Minimum compressive strength at 10% relative deformation, according to EN 826.

Durability assessment of slabs, both CONLIT[®] 150 P and CONLIT[®] 150 AF, confirms a working life of 25 years for the intended use Z₂ (internal use). According to ETAG 018-4, resistance to deterioration caused by water, resistance to soak/dry, resistance to freeze/thaw and resistance to heat/rain are characteristics not relevant for the intended use Z₂ (internal use).

The ETA is issued for the slabs on the basis of agreed data/information, deposited with the ITeC, which confirm, according to ETAG 018 Part 4, section 5.2.7.2, that the products under assessment conform to their declared characteristics.

¹ TR 034 *General ER 3 Checklist for ETAGs/CUAPs/ETAs-Content and/or release of dangerous substances in products/kits*, Edition March 2012.

² The manufacturer is member of EUCEB (European Certification Board for Mineral Wool Products) and the mineral wool used for CONLIT[®] 150 P and CONLIT[®] 150 AF has the EUCEB's certificates.

4 Assessment and verification of constancy of performance (AVCP) system applied, with reference to its legal base

According to the decision 1999/454/EC of the European Commission, the system of AVCP (see EC delegated regulation (EU) No 568/2014 amending Annex V to Regulation (EU) 305/2011) given in the following table applies.

Table 4: AVCP System.

Product(s)	Intended use(s)	Level(s) or class(es)	System(s)
Fire protective products	For fire compartmentation and/or fire protection or fire performance	Any	1

5 Technical details necessary for the implementation of the AVCP system, as foreseen in the applicable EAD

All the necessary technical details for the implementation of the AVCP system are laid down in the *Control Plan* deposited with the ITeC³ and the factory production control shall be in accordance with it. The following table specifies properties that should be controlled and minimum frequencies of control.

Table 5: FPC test plan for CONLIT[®] 150 P and CONLIT[®] 150 AF.

Property	Minimum frequency
Incoming material	Every delivery
Organic content (reaction to fire)	1 per day
Insulation efficiency (small oven test)	1 per month
Thickness	1 per day, per thickness
Length, width, squareness	1 per day
Apparent density	1 per day
Compressive strength	1 per day
Flexural strength	1 per year
Dimensional stability	1 per year

Issued in Barcelona on 29 May 2015
by the Catalonia Institute of Construction Technology.



Ferran Bermejo Nualart
Technical Director, ITeC

³ The *Control Plan* is a confidential part of the ETA and only handed over to the notified product certification body involved in the assessment and verification of constancy of performance.

ANNEX 1. Resistance to fire performance of load-bearing steel elements protected with slabs CONLIT® 150 P and CONLIT® 150 AF

A.1.1 Classification

The assemblies described in this Annex have been tested and evaluated according to ENV 13381-4 and classified in accordance with EN 13501-2.

The assessment of the required thickness of CONLIT® 150 P and CONLIT® 150 AF at the design temperature of 500 °C, in function of the section factor of the steel element and the exposure time to the standard time-temperature curve defined in EN 1363-1, is given in table A.1.1.

Table A.1.1: Fire resistance classification of protected structural steel members.

Structural steel element	Fire resistance classification								
Section factor A_m/V (m ⁻¹)	R15	R30	R45	R60	R90	R120	R180	R240	R300
Minimum thickness (mm) to maintain temperature below a design temperature of 500°C									
45	19	19	19	19	19	23	46	69	91
50	19	19	19	19	19	27	51	75	100
60	19	19	19	19	20	33	60	87	-
70	19	19	19	19	24	39	68	98	-
80	19	19	19	19	28	44	75	107	-
90	19	19	19	19	31	48	82	-	-
100	19	19	19	19	34	52	87	-	-
110	19	19	19	19	37	55	92	-	-
120	19	19	19	20	40	59	97	-	-
130	19	19	19	22	42	61	101	-	-
140	19	19	19	23	44	64	105	-	-
150	19	19	19	25	46	66	-	-	-
160	19	19	19	26	47	69	-	-	-
170	19	19	19	27	49	71	-	-	-
180	19	19	19	28	50	72	-	-	-
190	19	19	19	29	52	74	-	-	-
200	19	19	19	30	53	76	-	-	-
210	19	19	19	31	54	77	-	-	-
220	19	19	20	32	55	78	-	-	-
230	19	19	21	32	56	80	-	-	-
240	19	19	21	33	57	81	-	-	-
250	19	19	22	34	58	82	-	-	-
260	19	19	22	34	59	83	-	-	-
270	19	19	23	35	60	84	-	-	-
280	19	19	23	35	60	85	-	-	-
290	19	19	23	36	61	86	-	-	-
300	19	19	24	36	62	87	-	-	-
310	19	19	24	37	62	88	-	-	-
320	19	19	25	37	63	88	-	-	-
330	19	19	25	38	63	89	-	-	-
340	19	19	25	38	64	90	-	-	-
350	19	19	25	38	65	91	-	-	-
360	19	19	26	39	65	91	-	-	-
370	19	19	26	39	66	92	-	-	-
380	19	19	26	40	66	92	-	-	-
390	19	19	27	40	66	93	-	-	-
400	19	19	27	40	67	94	-	-	-
403	19	19	27	40	67	94	-	-	-

A.1.2 Installation requirements

Fire protective slabs can be assembled according to two installation methods: mechanically fixed (see A.1.2.4) or bonded (see A.1.2.5). In both cases, system should be installed in accordance with manufacturer's instructions and the provisions given in the following clauses.

A.1.2.1 Structural steel elements

The supporting structure consists of load-bearing steel elements with the following characteristics:

- 'H' or 'I' shaped beam and column sections.
For hollow sections, protection thicknesses given in table A.1.1 can be applied using the given section factor of the hollow section.
- Steel grades according to ENV 13381-4.
- Section factors as given in Table A.1.1.
- Three-sided fire exposure for beams and four-sided fire exposure for columns.
In case of beams or columns with fewer sides exposed to fire, slab thickness can be applied according to table A.1.1 under consideration of the section factor calculated for the particular case.

A.1.2.2 Fire protective slabs

CONLIT[®] 150 P or CONLIT[®] 150 AF slabs shall be as described in section 1 of this ETA. Any part of the structural element exposed to fire shall be cladded by CONLIT[®] 150 P or CONLIT[®] 150 AF slabs of the required thickness.

Slabs are cut to size preferably with a saw or a knife and fixed in a single layer to form an encasement around the steel element.

A.1.2.3 Joints

Fire protective slabs shall be butt jointed. All joints between slabs are completely filled with glue CONLIT[®], as well as joints between slabs and floors.

In the case of systems with CONLIT[®] 150 AF, all joints between slabs are covered with an adhesive tape of aluminium (See Figures A.1.5 and A.1.6, also valid for the bonded system in section A.1.2.5).

Table A.1.2: Specification of components for the joints.

Element	Identification	Characteristics	Mounting and fixing
Joint material	Glue CONLIT [®]	Beige viscous glue based on sodium silicate, pigments and other components.	To fill all joints
Aluminium tape	Adhesive tape of aluminium	Width \geq 50 mm	To cover the transversal joints between slabs
		Width \geq 175 mm	To cover the joints at the corners

A.1.2.4 Mechanically fixed system

Steel pins are welded to the flanges of the steel element at maximum 400 mm centres. The distance from the welded pins to the transversal slab joints is 100 mm. Once cut, the slabs are placed on the steel element being bored by the pins and held with anti-return washers.

Table A.1.3: Specifications of fixing components.

Element	Identification	Characteristics	Mounting and fixing
Welded pins	Cu-coated steel pins according to EN ISO 13918	Diameter \geq 3 mm Length: double of the slab thickness	Welded to the flanges of the steel element at \leq 400 mm centres
Anti-return washers	Zincated steel washers	Diameter \geq 35 mm	Placed to hold the slabs

Installation of the mechanically fixed system shall be done in accordance with the following figures.

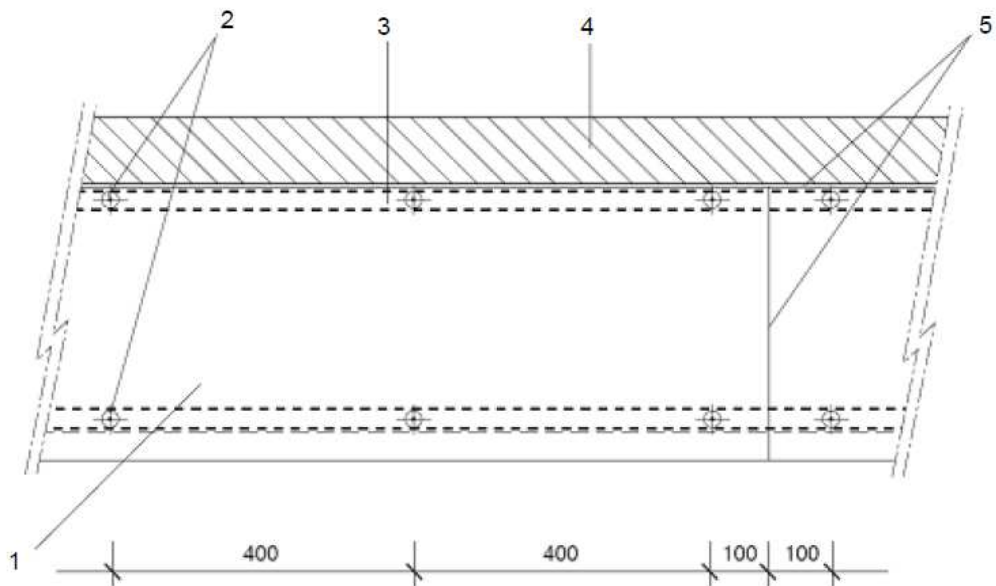

Figure A.1.1: Elevation of a beam.

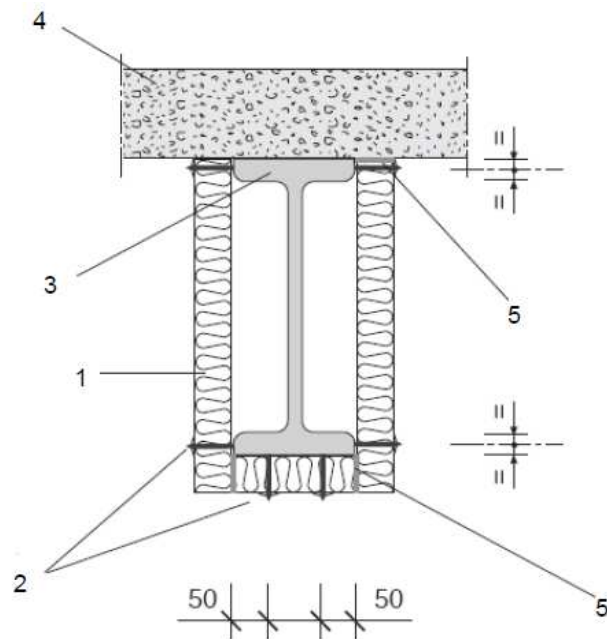

Figure A.1.2: Beam section.

- | | |
|---|---|
| 1 | Fire protective slabs CONLIT [®] 150 P or CONLIT [®] 150 AF |
| 2 | Welded steel pins and anti-return washers |
| 3 | Load bearing steel elements |
| 4 | Floor |
| 5 | Glue CONLIT [®] |
| 6 | Aluminium tape, width ≥ 175 mm |
| 7 | Aluminium tape, width ≥ 50 mm |

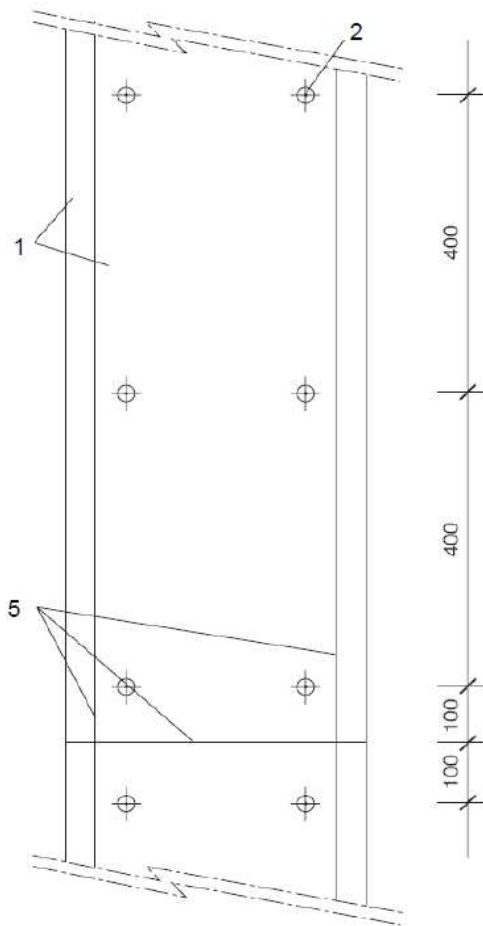

Figure A.1.3: Elevation of a column.

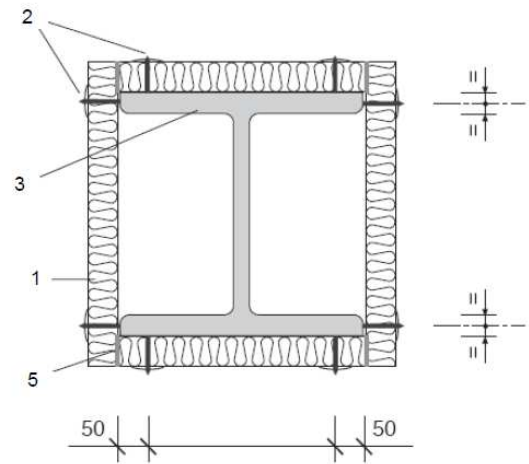

Figure A.1.4: Column section.

Details of joints in case of CONLIT[®] 150 AF

(also valid for installations according to A.1.2.5)

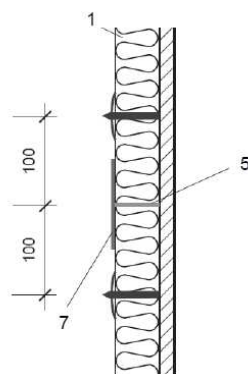

Figure A.1.5: Transversal joints between slabs.

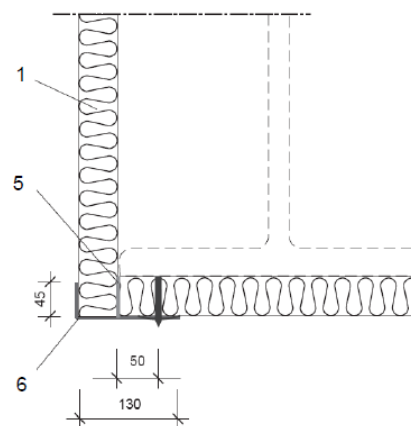

Figure A.1.6: Longitudinal joints in corners.

A.1.2.5 Bonded system

Blocks cut from CONLIT® 150 P slab of the same thickness as the flange depth are fitted between the flanges of the steel element at maximum 400 mm centres and bonded to them using glue CONLIT®. The blocks are 100 mm wide and of the same height as the web.

Once cut, the slabs are fixed to the blocks using glue CONLIT® and at least two galvanized steel nails in each block. The slabs are also fixed to each other at the corners to form an encasement using glue CONLIT® and the same type of nail at maximum 450 mm centres.

Table A.1.4: Specifications of components for fixing.

Element	Identification	Characteristics	Mounting and fixing
Blocks	CONLIT® 150 P	Width: 100 mm Thickness: flange depth Height: distance between flanges	Fitted between the flanges of the steel element, at ≤ 400 mm centres
Adhesive material	Glue CONLIT®	Beige viscous glue based on sodium silicate, pigments and other components.	- to fix the blocks to the flanges of the steel element - to fix the slabs to the blocks
Nails	Galvanized steel nails	Diameter ≥ 2 mm Length: double of the slab thickness	- to fix the slabs to the blocks (at least two nails in each block) - to fix the slabs to each other at the corners, at ≤ 450 mm between centres

Installation of the bonded system shall be done in accordance with the following figures.

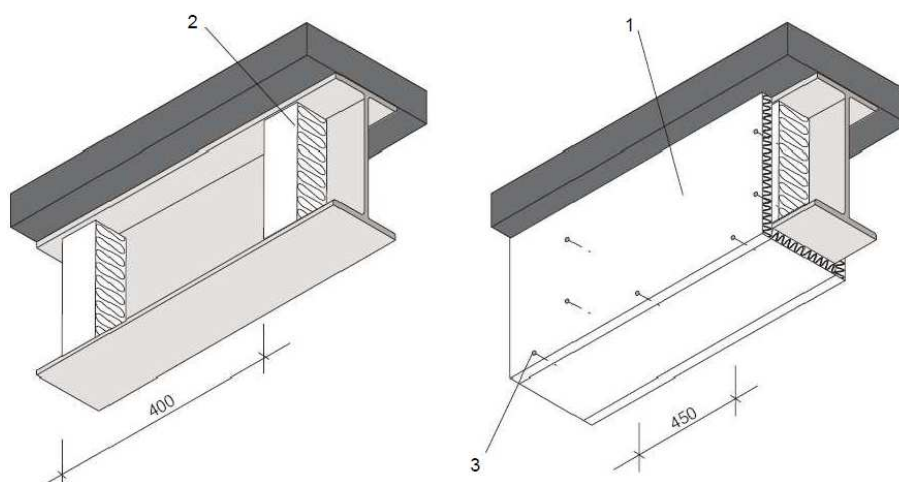

Figure A.1.7: General view of a beam.

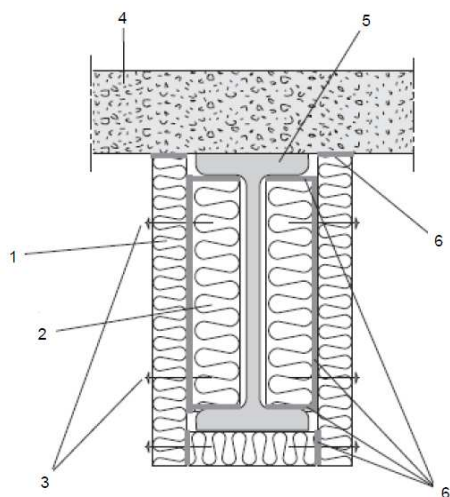

Figure A.1.8: Beam section.

- | |
|---|
| <ul style="list-style-type: none"> 1 Fire protective slabs CONLIT® 150 P or CONLIT® 150 AF 2 CONLIT® 150 P blocks 3 Galvanized steel nails 4 Floor 5 Load bearing steel elements 6 Glue CONLIT® |
|---|

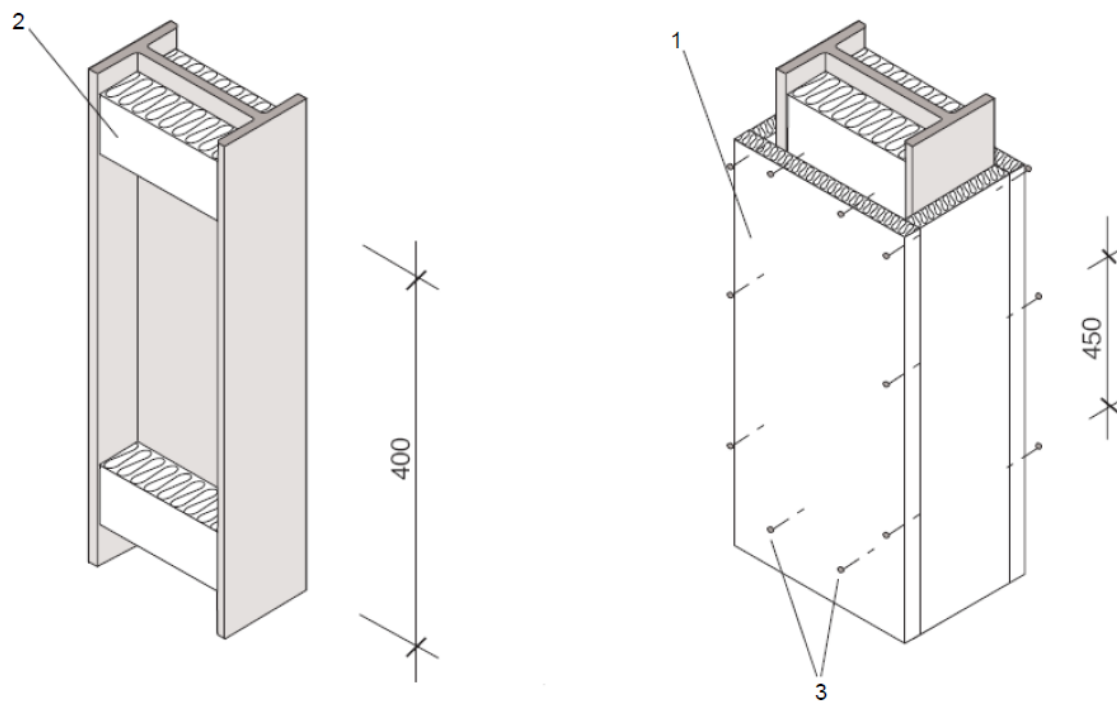

Figure A.1.9: General view of a column.

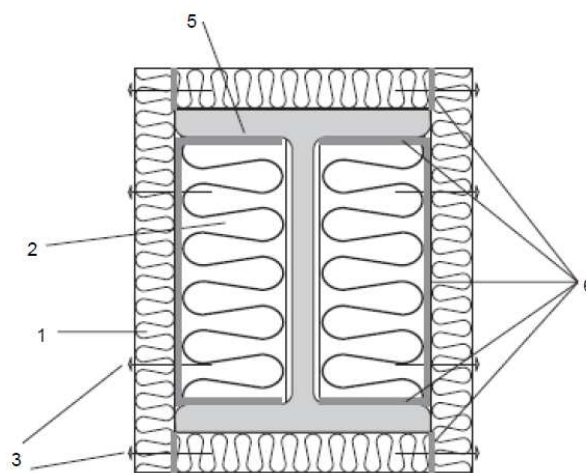

Figure A.1.10: Column section.