

DAU

14/086 D

Documento
de adecuación al uso
Fitness for use
document

Trade name

Cáviti®

Generic type and use

Plastic parts system for formation of permanent formworks in construction of raised floors in general and substitution of crawl space floors.

Holder of DAU

**FORJADOS SANITARIOS
CÁVITI SLU**

Av. Manuel Rivera 3, office
ES34002 Palencia. Spain
Tel. 979 69 38 89
www.caviti.com

Manufacturing plant

Cáviti - Plásticos de Palencia
Pol. Industrial Venta de Baños – Parcela 170 - 172
ES34200 Venta de Baños (Palencia). Spain

Cáviti - Envaplas
Camí Pla de Museros 6, Pol. Industrial Les Forques
ES12550 Almazora (Castellón). Spain

Valid edition and date

D 11.10.2023

Validity (subjected to annual monitoring [*])

From: 22.12.2019
To: 21.12.2024

Date of initial issuing of the DAU

22.12.2014

[*] The validity of DAU 14/086 is subject to the *Reglamento del DAU* conditions. The valid edition of this DAU is found in the ITeC register maintained by ITeC (available on itec.es and through the next QR code).



This document contains 32 pages.
Its partial reproduction is forbidden.

ITeC is an authorized organism for awarding the DAU ([BOE 94, 19 April 2002](#)) for construction products (building and civil engineering) registered in the General Register of the CTE (Resolution of 3 September 2010 – Spanish Department of Housing).

ITeC

Control of editions

Edition	Date	Sections where changes have been made regarding the previous edition
A	22.12.2014	Creation of the document.
B	11.07.2019	Change of holder address. Cáviti - Envaplas manufacturing centre is added. Change of width of parts C-45, C-50 and C-55.
C	22.12.2019	Revision and technical update of the DAU in accordance with the current editions of the reference documents (CTE updates and other reference standards). Extension of the validity of the DAU until 21.12.2024.
D	11.10.2023	Adaptation of the DAU to the Structural Code, which replaces the previous Code on Structural Concrete EHE-08.

Contents

1.	Description of the system and intended uses	5
1.1.	Definition of the construction system	5
1.2.	Intended uses	5
1.3.	Limitations of use	5
2.	System components	6
2.1.	Cáviti® parts	6
2.2.	Perimeter profile	7
2.3.	Concrete	7
2.4.	Reinforcements	7
2.5.	Perimeter ring beam	9
2.6.	Panels of expanded polystyrene for joints	9
3.	Manufacture and control of production	10
3.1.	Manufacture	10
3.1.1.	Raw materials	10
3.1.2.	Manufacturing process	10
3.1.3.	Presentation of the product	10
3.2.	Control of production	10
3.2.1.	Control of raw material	10
3.2.2.	Control of the manufacturing process	10
3.2.3.	Control of the final finished product	10
4.	Storage, transport and reception on site	11
4.1.	Storage and transport	11
4.2.	Control of reception on site	11
5.	Design criteria	11
5.1.	Structural safety	11
5.1.1.	Placement on the ground	12
5.1.2.	Assembly on a floor or foundation slab	13
5.2.	Safety in case of fire	14
5.2.1.	Reaction to fire	14
5.2.2.	Resistance to fire	14
5.3.	Hygiene and health	14
5.3.1.	Watertightness	14
5.3.2.	Limitation of condensation	15
5.3.3.	Other aspects of the system	15
5.4.	Safety in use	15
5.5.	Protection against noise	15
5.6.	Energy economy and heat retention	15
5.7.	Other design criteria	15
5.7.1.	Durability	15
5.7.2.	Dimensional aspects of the system	16
5.7.3.	Construction details	16
6.	Installation, maintenance and repair criteria	17
6.1.	Installation criteria	17
6.1.1.	Prior conditions	17
6.1.2.	Placement of the Cáviti® parts	17
6.1.3.	Perimeter solutions and joints with columns	17
6.1.4.	Other singular points	18
6.1.5.	Concreting	18
6.1.6.	Requirements to be met by fitters	19
6.2.	Criteria for maintenance and repair	19
6.3.	Construction details	20

7.	References of use	25
8.	Site visits	25
9.	Assessments of tests and calculations	26
9.1.	Introduction	26
9.2.	Characterisation tests of the system elements	26
9.2.1	Characterisation of Cáviti® parts	26
9.2.2	Characterisation of the concrete	26
9.2.3	Anti-crack reinforcement	26
9.3.	Tests and calculations of fitness of use of the system	27
9.3.1.	Mechanical resistance and stability and safety of use	27
9.3.2.	Safety in case of fire	27
9.3.3.	Hygiene, health and the environment	27
9.3.4.	Protection against noise	27
9.3.5.	Energy economy and heat retention	27
9.4.	Assessment tests of the system in the assembly process	28
9.4.1.	Resistance to concreting stress	28
9.4.2.	Formwork resistance to compression	28
10.	Experts commission	28
11.	Reference documents	29
12.	Assessment of fitness for use	30
13.	DAU monitoring	31
14.	Use conditions of DAU	31
15.	List of changes of the present edition	32

1. Description of the system and intended uses

1.1. Definition of the construction system

Cáviti® is a permanent formwork system formed by joining parts of recycled polypropylene, for the construction of raised floors and raised structures. The range of available parts makes it possible to reach different heights of raised floor depending on the characteristics of the project (see table 2.1).

The joining of the parts creates a permanent formwork that, by being filled with concrete, forms a continuous floor, domed on its lower face and supported on the columns that are formed by the union of four Cáviti® parts. The parts are joined together thanks to the perimeter rebates and in the order marked by the indicative arrows located on the top dome of the modules.

The system does not include any type of special parts for encounters with protruding elements or perimeters, or in the event that the screed must be drilled to pass sanitation or electrical installation equipment through it. These particular points are dealt with by cutting the parts, using a circular (radial) cutting machine, a jigsaw with a special saw for plastic or a drill with a hole saw, as needed. Before cutting, the need to lay out the modules to assess their encounters with existing elements and with the passage of installations through the upper dome of the modules should be considered.

A perimetral polypropylene profile is included in the system, of different sizes according to the height of the Cáviti® parts to be put into place, which serves the purpose of preventing material from being lost when pouring concrete in certain cases, such as in perimeters in which there is no vertical element against which to fill the Cáviti® parts (see section 2.2).

Thus, the purpose is to create a permanent formwork that occupies the entire surface to be covered with concrete. A reinforcement should be placed close to the upper face of the final floor, to avoid possible shrinkage cracking. The concreting can be carried out with a pump truck or with a bucket, but in any case, it must be carried out in a controlled manner, since excessively rapid pouring can damage the installation, for example, by opening the formwork.

1.2. Intended uses

The Cáviti® system is used for the elevation of floors in general, for example, in floors in contact with the ground in substitution of a traditional crawl space floor, screeds on existing floors, refurbishments, pedestrian areas and platforms, changing room areas, lightweight decking, etc.

The use of Cáviti® parts is basically to form the permanent formwork. This must be able to support the passing of staff on site and the stress caused by concreting. Once the concrete has set, this resistance of the formwork is negligible compared to that of concrete.

The permanent formwork forms a layer of polypropylene that covers the entire lower surface of the screed, providing it with some watertightness. However, it should be taken into account that the joints between Cáviti® parts are not completely watertight, or may open slightly during concrete pouring, leaving small gaps through which moisture can get in.

The final concrete system forms a raised floor which, when placed on the ground, can be used in substitution of a crawl space floor. It should be kept in mind that this raised floor is not part of the structure of the building and that it rests on the ground at several points. The height of the parts used in this case must be adequate to guarantee the ventilation corresponding to this type of crawl space floors.

1.3. Limitations of use

This DAU (Document of Assessment for fitness of Use) considers that the Cáviti® system should be used in compliance with the following conditions:

- The concreting must be carried out with concrete of the type defined in section 2.3 or offering equal or greater resistance to that which is indicated. The use of fluidised concrete is discouraged.
- The system is not designed for special loads such as:
 - High static loads (for example, in industrial buildings with very heavy machinery).
 - High dynamic loads (for example, in car parks for heavy vehicles).
- The support must be level enough for the parts to be able to settle well.
- The system allows the screed to be raised up to 70 cm (without counting the compression layer).

Parts of different heights can be stacked in order to achieve a greater height only when so indicated by the technical department of Forjados Sanitarios Cáviti SLU.
- The compression layer must have a thickness of ≥ 5 cm. Thinner layers do not fall within the scope of this DAU (Document of Assessment for fitness of Use) and must be justified in each particular case.
- Anti-crack reinforcement must always be put into place.
- The construction solutions presented in this DAU document must be respected.

- The use of different Cáviti® part models on the same surface must be carried out by separating them with perimeter profiles (see section 2.2).
- The Cáviti® system should not be used with expansive soils. In these cases, the Cáviti® system must rest on foundations formed by rigid reinforced slabs that contain such expansivity.
- The raised floor does not have a bracing function of the structure at its base.

As indicated in the project criteria (see section 5.1), there may be other limitations of use depending on the specific parameters of the works.

2. System components

2.1. Cáviti® parts

Cáviti® parts are manufactured with black thermo-injected recycled polypropylene, which in some cases may have grey shades due to added mineral loads.

The elevation of the parts has a vaulted geometry in two directions, slightly flat in the upper part, and with a rectangular base. The upper part forms ribs that start at the central part of the piece and descend through its geometry until it is derived to the structural columns of the formwork located in the vertices of the piece. Each column of the piece comprises a quarter of the structural column that is formed by joining four Cáviti® formwork modules.

On two contiguous sides of the part (one larger and the other smaller of the rectangular geometry) there is a rebate in the form of a negative dovetail that is used in the union between parts. On the other two sides is the positive rebate of the joint. The dovetail joint between parts is carried out along the entire perimeter of these.

The structural ribs ensure the strength of the part and allow staff to work on the parts during the construction process.

Part	Base dimensions (mm)	Surface (m ²)	Total height (mm)	Interior height (mm)	Concrete consumption up to the dome of the module (l/m ²)	Supporting surface (cm ² /column)	Columns per m ²
C-5	580 x 400	0,232	50	20	4,5	50	25,9
C-10	780 x 580	0,452	100	73	10,5	64	26,5
C-15	750 x 500	0,375	150	95	30	462	2,67
C-20	750 x 500	0,375	200	145	35	419	2,67
C-25	750 x 500	0,375	250	190	40	380	2,67
C-30	750 x 500	0,375	300	240	43	342	2,67
C-35	750 x 500	0,375	350	290	49	306	2,67
C-40	750 x 500	0,375	400	345	53	272	2,67
C-45	750 x 500	0,375	450	400	77	322	2,67
C-50	750 x 500	0,375	500	450	81	282	2,67
C-55	750 x 500	0,375	550	500	84	237	2,67
C-60	750 x 500	0,375	600	550	93	355	2,67
C-65	750 x 500	0,375	650	600	97	316	2,67
C-70	750 x 500	0,375	700	650	102	278	2,67

Table 2.1: Main features of Cáviti® parts.

The dimensions and other relevant characteristics of the range of parts considered in this DAU document are summarised in table 2.1. The geometry of each is shown in Figures 2.1a and 2.1b.

The morphology of the parts allows the final screed to be considered a raised floor, as defined in the DB-HS (Basic Health and Safety Document) of the CTE (Technical Building Code), which considers it as a floor at the base of the building in which the ratio between the sum of the surface of contact with the ground and the one of support, and the surface of the ground is inferior to 1/7.

2.2. Perimeter profile

Perimeter profiles are flat parts of recycled polypropylene primarily intended to cover free perimeters and prevent poured concrete from spilling.

The range of perimeter profiles is presented in the same heights as the Cáviti® parts. In addition, they have a 8 cm strip perpendicular to the main height of the profile, which is placed as a base to give stability to the profile under the feet of the columns of the Cáviti® parts.

The perimeter profiles are joined with the Cáviti® parts by means of a wire or with plastic flanges, which pass through perforations carried out on site in both elements, at the points that are considered most suitable to prevent the massive loss of concrete through the joints. The perimeter profile can be cut, if necessary, by means of a cutter or jigsaw.

Table 2.2 shows the main dimensions of the perimeter profiles.

2.3. Concrete

The type of concrete to be used is not limited. No impediment is foreseen to use any type of concrete considered in the Structural Code. The type of concrete will depend mainly on the mechanical resistance provided for the screed and the environment in which it is located and will be defined in the project phase.

The DAU holder recommends using 20 N/mm² plain concrete or 25 N/mm² reinforced concrete. Concrete type HM-20/B/25/X0, HA-25/B/25/XC2, or of higher performance is considered suitable for standard exposure classes with high humidity. These concretes can be poured by pump or bucket.

The use of fluidised concrete is discouraged, since the joints between parts are not completely watertight and this can cause loss of material.

Part	Length (m)	Height + Overlap (cm)	Thickness (mm)
P-10	2,00	10 + 8	4
P-15	2,00	15 + 8	4
P-20	2,00	20 + 8	4
P-25	2,00	25 + 8	4
P-30	2,00	30 + 8	4
P-35	2,00	35 + 8	4
P-40	2,00	40 + 8	4
P-45	2,00	45 + 8	4
P-50	2,00	50 + 8	4
P-55	2,00	55 + 8	4
P-60	2,00	60 + 8	4
P-65	2,00	65 + 8	4
P-70	2,00	70 + 8	4

Table 2.2: Main features of the perimeter covers.

2.4. Reinforcements

The reinforcement in the Cáviti® type screeds is used to prevent shrinkage cracking of the most superficial areas of the concrete. In addition, in models higher than C-15, it also helps concreting work, since it prevents workers from stepping inside the cavity of the structural columns.

In general, electro-welded wire meshes will be used in accordance with UNE36092 standard:

- Type B-500T
- Dimensions ME 15x15, ME 15x20, ME 20x20, ME 15x30 or ME 20x30
- Diameters 6, 8, 10 and 12 mm

Depending on the actions planned on the screed, the placement, dimensions of the grid and diameter of the bars will be defined. In cases where the intention is to have a compression layer greater than 5 cm, conventional reinforcement separators must be placed in order to ensure the cover indicated in section 6.1.5.1.

The concrete can also be reinforced with virgin polypropylene fibres, if it is considered necessary for mechanical reasons. When installing them, the instructions in section 6.1.5 must be taken into account.

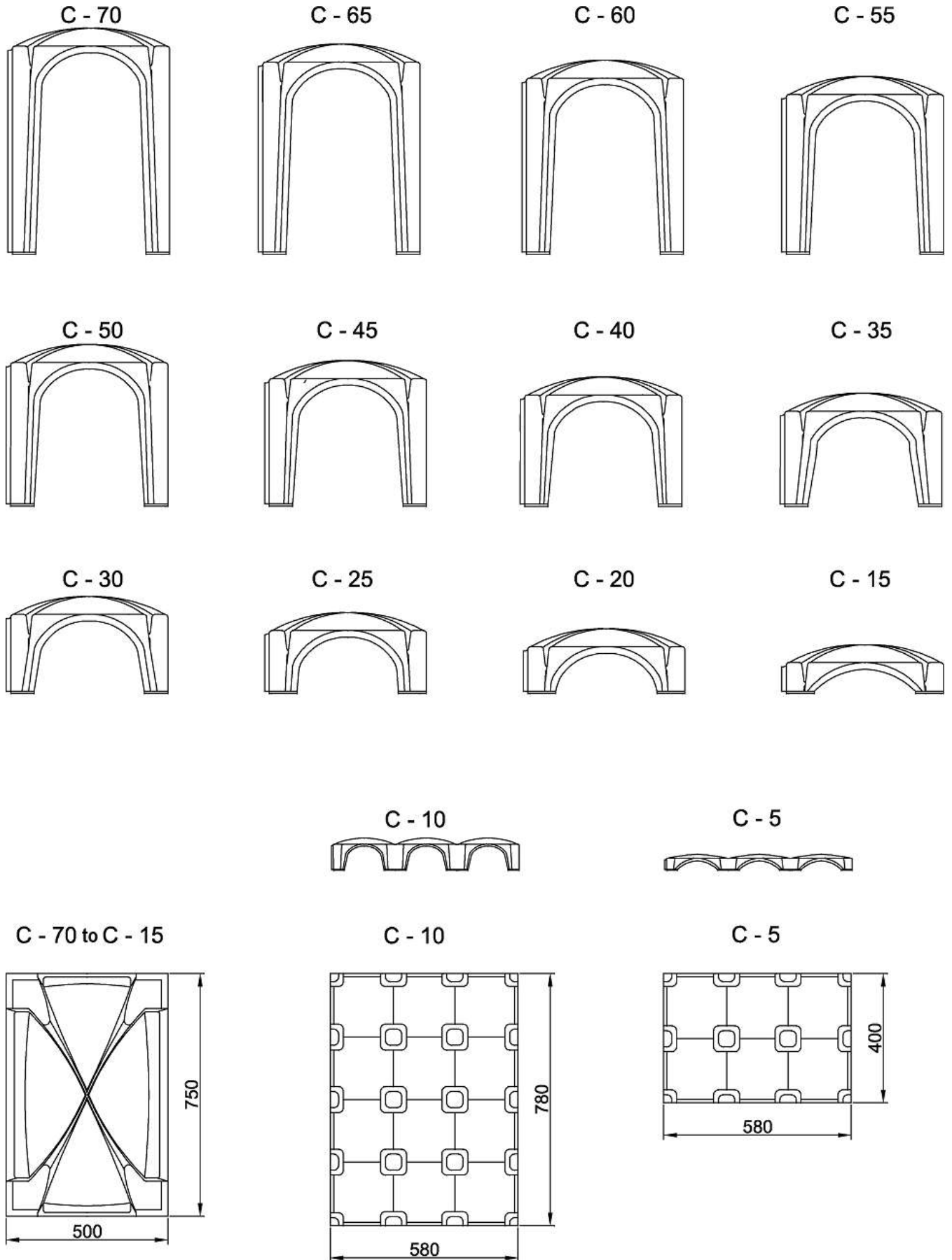
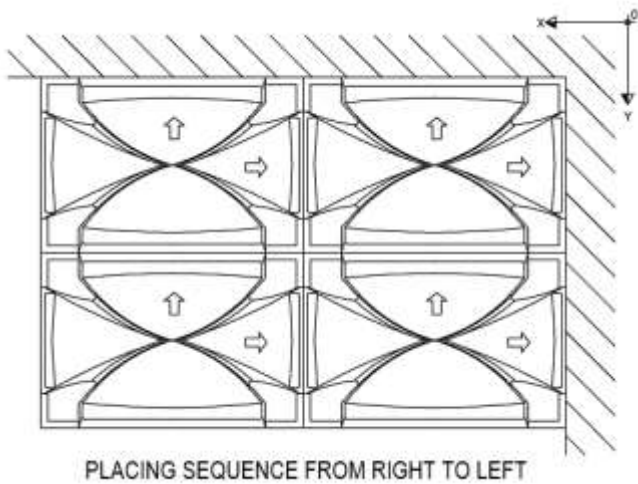
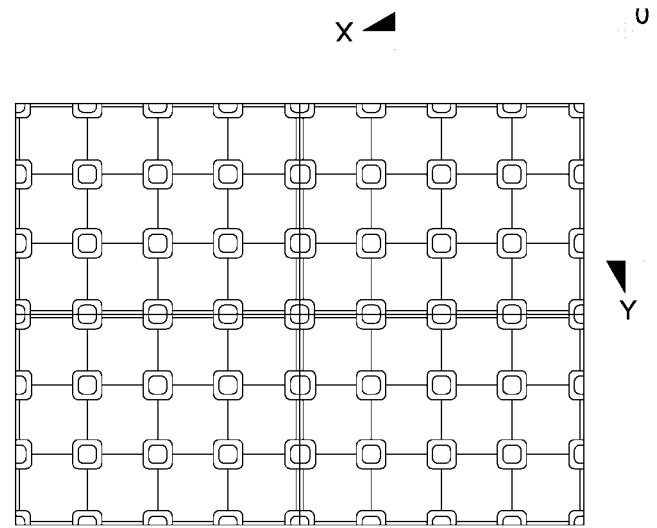

Figure 2.1a: Elevation and plan of the Cáviti® parts (in mm).

Parts C-15 to C-70



Parts C-10



Parts C-5

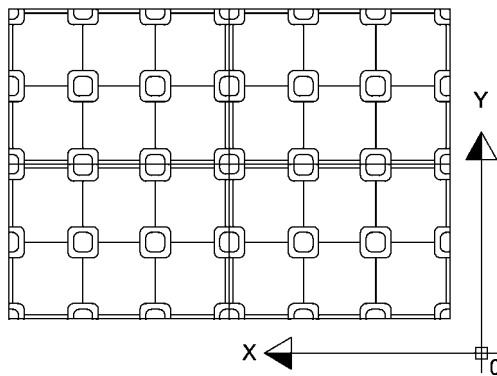

Figure 2.1b: Assembly of the Cáviti® parts. Direction of placement of the parts.

2.5. Perimeter ring beam

When it is necessary to cut the Cáviti® parts where they meet a perimeter due to modulation needs, a perimeter ring beam can be implemented, continuous with the compression layer and the rest of the screed, which prevents this end of the screed from working as a cantilever. A perimeter ring beam can also be created in order to adjust the encounter with the perimeters to the modulation of the parts and not have to use cut parts.

The concreting of the ring beam will be carried out along with the entire structure of the screed so that the concrete will be the same according to the specifications in section 2.3. The trimmed Cáviti® part must have a perimeter cover to prevent concrete from pouring down to the bottom of it, as well as a support made with perforated brick so that it does not overturn.

The perimeter ring beam is at least 20 cm to 25 cm wide and is as tall as the Cáviti® part plus the compression layer. It is not necessary to lay reinforcement, but if it is considered necessary for design reasons, it is recommended to place steel type B 500S of 12 mm in diameter in the amount specified in the project. For each

project, details are made of the critical points in which the ring beam reinforcements are specified.

The criteria for using this element are listed in section 6.1.3.3.

2.6. Panels of expanded polystyrene for joints

The use of expanded polystyrene panels is generally contemplated in connections and joints to be concreted (see sections 6.1.3 and 6.1.4).

In general, the polystyrene panels are at least 3 cm thick, but with no specific requirement in terms of resistance, density or other characteristics.

3. Manufacture and control of production

3.1. Manufacture

3.1.1. Raw materials

The raw material to manufacture Cáviti® parts is recycled copolymer polypropylene, supplied in chippings or crushed up, completely washed and free of contaminating matter. It is black or with shades of grey.

3.1.2. Manufacturing process

The Cáviti® modules are manufactured by a thermo-injection process in steel moulds. In each mould only one part is manufactured. From a certain height of the parts, the manufacture is carried out by means of supplements of the moulds that give rise to different heights.

3.1.3. Presentation of the product

The Cáviti® parts are presented stacked, protected with polyethylene film and fastened with plastic strapping. The units in each package are indicated in table 3.1, depending on the type of part. They can be palletized if the transport demands it.

Each package is labelled indicating the model, number of parts, square metres, client it is intended for and total number of packages per order. Each order has its corresponding delivery note indicating the client, address, contact telephone number, model, number of parts, total square footage and number of packages. In each package, a product installation manual is attached.

Parts	Layout in the package	Units per package	Approximate surface area on site (m ²)
C-5	4 piles of 125 units each	500	116
C-10	2 piles of 70 units each	140	63
C-15 to C-40	2 piles of 50 units each	100	37
C-45 to C-55	2 piles of 45 units each	90	33
C-60 to C-70	2 piles of 40 units each	90	33

Table 3.1: Presentation of Cáviti® parts.

3.2. Control of production

Forjados Sanitarios Cáviti SLU manufactures the Cáviti® parts in Cáviti - Plásticos de Palencia, in Venta de Baños, and Cáviti - Envaplas, in Almazora.

The production control system at the factory has been audited by ITeC, with a satisfactory result.

The characteristics that are controlled in the production control are indicated below.

3.2.1. Control of raw material

The received polypropylene is controlled by an organoleptic inspection, which controls its external appearance, how it feels to the touch and its humidity. A fluidity and quality test of the material is performed on the first injection of material.

3.2.2. Control of the manufacturing process

The control of the manufacture basically consists in taking care of the injection process, which in most cases is automatic. The removal of the mould and the start of the injection is controlled, and the possible excess material is eliminated.

3.2.3. Control of the final finished product

The final product control is based on a visual inspection of the following aspects:

- Presence of bubbles, bursts, excess of material, shiny patches, junction lines and rivers of material
- Deformities and breakages
- Lack of material
- Oil spots

Load tests are also performed each time the raw material is changed.

4. Storage, transport and reception on site

4.1. Storage and transport

The Cáviti® parts can be stored under cover or in the open, since the material is not affected by weather conditions. It is not advisable, however, that the material be exposed to weather for long periods of time (longer than two months, according to the manufacturer's indications), since the parts may become fragile and lose some mechanical strength.

It is not recommended to remount packets of parts or pallets, as it may cause the deformation of the parts at the bottom. Likewise, it is recommended to store the material in a place outside the range of possible blows that could break the parts.

No specific requirements are considered for the transport of the parts. In general, the parts are packaged in the format indicated in table 3.1, but can be supplied placed on a pallet, if the transport company requires it to be done in this way.

4.2. Control of reception on site

A check must be carried out on site to make sure that the modules received are in good condition: they have not suffered excessive deformation, they do not have any breakages, they do not present faults of material, or any other defect that may compromise the sealing of the formwork or its resistance. Any parts that do not fit correctly should be disposed of.

5. Design criteria

The design of the Cáviti® system will be based on the fulfilment of the basic quality requirements of the Technical Building Code (hereinafter CTE) as indicated in the basic documents DB-SE-AE, DB-SE-C, DB-SI, DB-HS, DB-SU, DB-HR and DB-HE, in addition to the requirements stipulated in the Structural Code. In each project the suitability of the constructive solutions chosen must be checked.

The following are a set of criteria that should be considered in a project with the system under the DAU.

5.1. Structural safety

The Cáviti® system is used to form a permanent formwork that is filled with concrete in order to form a raised floor. Once concrete has been poured, the resistant capacity of the screed is conferred by the concrete, which has formed a raised floor of variable thickness (compression layer of minimum 5 cm) that has inverted pyramidal trunk columns that transmit the loads to the support leant on.

Laboratory tests, both of distributed load and point load, show that the resistance of these screeds can be very high if installed on a rigid support.

According to the results of the tests and the calculations made in the case of distributed loads, it is observed that, in general, the critical point of this system is not the resistance of the screed, but the behaviour of the support on which it is placed. The stress of compression that these types of screeds can withstand is very high, as the tests show, but the shape of the Cáviti® screed is not designed to be flexible if the support fails. If the support is excessively deformed or the columns of the screed sink or punch shear the support, the cracking or breaking of the screed may be caused, because the thickness and the anti-cracking reinforcement of the compression layer cannot withstand the flexion caused by the weight of this screed without support. The columns of the screed must always be supported on a sufficiently rigid and flat support.

In the case of point loads, the failure mechanism of the screed depends to a large extent on the resistance of the support surface, according to the tests and calculations carried out (tests carried out with a load applicator of 5 cm x 5 cm). On areas that are not very resistant, the main mechanism will be similar to that indicated for distributed load: sinking of the columns in the ground, causing an inadmissible bending of the screed. However, in very resistant areas or on slabs, the failure mechanism can be caused by bending/punching shear of the screed due to point loads.

For this reason, in the design phase, both the suitability of the screed and the support in service of the building should be evaluated, in order to avoid the breakage of

the Cáviti® screed. In general, imposed loads can be taken from table 3.1 of the DB-SE-AE. In cases of known concentrated loads, it is recommended to perform a particular calculation to evaluate the resistance of the support.

As a reference, table 5.1 indicates the results, duly minorated, of the tests performed. As indicated in the first paragraph, these values correspond to a screed placed on a very rigid support (laboratory conditions). On the other hand, tables 5.2a and 5.2b give the weights of the Cáviti® screeds per square metre, as well as the resulting pressure on the base of each column, considering a concrete density of 2.500 kg/m³.

The following sections provide criteria for the consideration of the permissible loads in the project phase, depending on the type of support used.

5.1.1 Placement on the ground

Placement on the ground must always be carried out by placing a layer of HM-20 lean concrete (with or without mesh) of a minimum thickness of 5 cm, whose function is to regulate the surface to provide a good support for the Cáviti® parts. The support of the parts is very important to prevent the concrete from opening the legs formed by the columns when being poured, as well as ensuring that, once it is set, all columns of the raised floor will be in contact with the support.

In this case, actions on the ground must be checked, taking into account:

- The weight of the concreted screed itself
- The weight of the lean concrete layer
- The foreseen imposed loads

The weight of the screed is calculated based on the concrete consumption of each part (see table 2.1, in section 2.1) and the thickness of the compression layer. With this data and the density of the concrete, the weight per square metre of the screed can be calculated. It should be taken into account in calculating the stress that this weight concentrates on the lower surface of the columns, which can result in punching shear of the ground. The lean concrete layer should not be considered a distributor of loads, due to its thickness, and as, in general, it is not reinforced.

The calculation of the resistance and the possible actions of the ground must be carried out taking into account the considerations of the DB-SE-C of the CTE.

In no case should the load concentrated in the area of the column be superior to the load capacity of the ground, to avoid the sinking of the column, and the subsequent breaking of the screed.

In collapsible grounds, where differential settlements are foreseen or which are located below the water table, it is recommended to install the Cáviti® system on a foundation slab, or another solution suitable for each particular case. In any case, the constructive conditions and the conditioning of the grounds and foundations indicated in the DB-SE-C must be considered.

Table 5.3, obtained from the test results, summarises the predicted breaking mechanism according to the resistance of the ground, and can be used as a reference in the design of the screeds.

In cases where it is considered that the failure is of the screed and not of the ground, the resistance of the screed is that which is indicated in the table of resistances of reference (table 5.1).

Part	Thickness of the compression layer (cm)	Resistance to point load of reference (*)		Resistance to distributed load of reference	
		(kN)	(kg)	(MPa)	(kg/m ²)
C-5 to C-10	5, 8 or 10	25,4 (**)	2.540 (**)	0,233	23.300
	5	11,5	1.150		
C-15 to C-70	8	20,4	2.040		
	10	27,4	2.740		

(*) Load applied on a surface of 5 cm x 5 cm.

(**) Due to the scatter of the test results available, a minimum characteristic value is given.

Table 5.1: Resistance of the Cáviti® screed to point load and distributed load, on rigid support.

Cáviti® Part	C-5	C-10	C-15	C-20	C-25	C-30	C-35
Dimensions (mm)	580 x 400	780 x 580	750 x 500	750 x 500	750 x 500	750 x 500	750 x 500
Area of the part (cm ²)	2.320	4.524	3.750	3.750	3.750	3.750	3.750
Area of a column (cm ²)	49,5	64	462	419	380	342	306
Columns/parts	6	12	1	1	1	1	1
Area Part/Area Column	7,8	5,9	8,1	8,9	9,9	11,0	12,3
Consumption of concrete (l/m ²)	4,5	10,5	30	35	40	43	49
Consumption of concrete/part (l)	1,0	4,8	11,3	13,1	15,0	16,1	18,4
Compression layer (cm)	Weight of the system per square metre of screed (N/m ²)						
5	1.363	1.513	2.000	2.125	2.250	2.325	2.475
8	2.113	2.263	2.750	2.875	3.000	3.075	3.225
10	2.613	2.763	3.250	3.375	3.500	3.575	3.725
Compression layer (cm)	Pressure on the base of a column (N/m ²)						
5	10.643	8.910	16.234	19.018	22.204	25.493	30.331
8	16.502	13.328	22.321	25.731	29.605	33.717	39.522
10	20.407	16.273	26.380	30.206	34.539	39.200	45.650

Table 5.2a: Weight of the system and pressure on a column for the parts C-5 to C-35.

Cáviti® Part	C-40	C-45	C-50	C-55	C-60	C-65	C-70
Dimensions (mm)	750 x 500	750 x 500	750 x 500	750 x 500	750 x 500	750 x 500	750 x 500
Area of the part (cm ²)	3.750	3.750	3.750	3.750	3.750	3.750	3.750
Area of a column (cm ²)	272	322	282	237	355	316	278
Columns/part	1	1	1	1	1	1	1
Area Part/Area Column	13,8	11,6	13,3	15,8	10,6	11,9	13,5
Consumption of concrete (l/m ²)	53	77	81	84	93	97	102
Consumption of concrete/part (l)	19,9	28,9	30,4	31,5	34,9	36,4	38,3
Compression layer (cm)	Weight of the system per square metre of screed (N/m ²)						
5	2.575	3.175	3.275	3.350	3.575	3.675	3.800
8	3.325	3.925	4.025	4.100	4.325	4.425	4.550
10	3.825	4.425	4.525	4.600	4.825	4.925	5.050
Compression layer (cm)	Pressure on the base of a column (N/m ²)						
5	35.501	36.976	43.551	53.006	37.764	43.612	51.259
8	45.841	45.710	53.524	64.873	45.687	52.512	61.376
10	52.734	51.533	60.173	72.785	50.968	58.445	68.121

Table 5.2b: Weight of the system and pressure on a column for the parts C-40 to C-70.

5.1.2 Assembly on a floor or foundation slab

In this case, the placement of a levelling layer is not necessary since, in general, the available support surface is sufficiently flat for the correct placement of the Cáviti® parts.

Both in the design of new builds and in renovations, the weight of the raised floor and the imposed loads must be taken into account in the calculation of the resistant capacity of the structure (floor or foundation slab). It is recommended to check the resistance of the support to the punching shear caused by the columns.

Parts	Thickness of the compression layer	Main mechanism of system failure based on ground resistance		
		Failure for punching shear of the ground in any case	Punching shear of the ground (in distributed load) or failure of the screed (in point load)	Failure of the screed in any case
C-5 to C-10	All cases	Up to 1 MPa		
	5 cm	Up to 0,10 MPa		
C-15 to C-55	8 cm	Up to 0,15 MPa		
	10 cm	Up to 0,20 MPa	Up to 4 MPa	From 4 MPa onwards
C-60 to C-70	5 cm	Up to 0,10 MPa		
	8 cm	Up to 0,20 MPa		
	10 cm	Up to 0,20 MPa		

Table 5.3: Mechanisms of failure predicted according to ground resistance and part size.

In structures where significant deferred deformation can be foreseen, it should be assessed whether these deformations can cause cracking of the compression layer of the Cáviti® floor by bending.

When considering point loads, it should be considered that these loads can cause failure by bending/punching shear of the compression layer of the Cáviti® screed, rather than excessive deformation of the floor screed or support slab.

In cases where the fault is considered to occur in the Cáviti® screed, and not due to the deformation of the support by bending, it can be considered that the resistance of the screed is that which is indicated in the reference resistance table (table 5.1).

5.2. Safety in case of fire

5.2.1. Reaction to fire

The reaction to fire of the polypropylene Cáviti® parts is class E and that of concrete is class A1, as indicated in section 9.3.2.1.

Table 4.1 of the DB-SI summarises the fire reaction requirements of the construction elements in those cases in which fire may spread inside the building. The Cáviti® system can be used in:

- Raised closed floors that do not contain equipment capable of starting or spreading a fire.
- Raised floors inside homes.
- Those cases in which the internal fire spread requirements of the DB-SI are not applicable, such as in raised exterior floors or in those cases where there is no chance of a fire starting or being spread inside the building.

Note 1: Raised floor is understood to be the different uses of the Cáviti® system, such as suspended flooring, ventilated screeds and raised floors.

Note 2: Closed means any element that has no perforation that connects it with the interior space of the building.

Cáviti® parts can be manufactured with flame retardant additives upon client request, although these products are beyond the scope of this DAU.

5.2.2. Resistance to fire

The elements executed with Cáviti® system are not structural elements that delimit fire sectors, so this requirement does not apply.

If this system is used on floor screeds that divide fire sectors, the resulting raised floor can be considered to significantly improve the fire resistance of the floor screed from a thermal point of view (criterion I). Furthermore, the weight of the raised floor must also be taken into account from the point of view of the bearing capacity in case of fire (criterion R).

5.3. Hygiene and health

5.3.1. Watertightness

The minimum degree of watertightness required to floors that are in contact with the ground against water penetration is defined in table 2.3 of the DB-HS, depending on the presence of water and the coefficient of permeability of the ground. The three degrees of presence of water on the ground (low, medium and high) are defined in point 2 of section 2.1.1 of the DB-HS, depending on the position of the ground with respect to the water table.

Table 2.4 of said DB indicates the conditions required for the most common construction solutions depending on the type of wall, the type of floor, the type of intervention on the ground and the degree of watertightness required. According to this table, for certain degrees of watertightness of the raised floor, a ventilation of the lower space must be foreseen (condition V1). In cases where a ventilated chamber solution is necessary, the criteria related to the propagation of fire inside the building must also be taken into account, as indicated in

section 5.2 of this DAU. When the required degree of watertightness involves the need for ventilation (degree of watertightness 3 or higher), and for reasons related to the spread of fire, this ventilation cannot be implemented, a screed or plate may be placed under the raised floor with the conditions indicated in table 2.4.

As indicated in section 9.3.3.1 of this DAU, the Cáviti® permanent formwork cannot be considered to provide watertightness to the building, since the joints between parts are not watertight.

5.3.2. Limitation of condensation

The project criteria related to possible condensation on the surface or in gaps are set out in section 5.6 of this DAU.

5.3.3. Other aspects of the system

Section 5.1.2 of the DB-HS of the CTE contains certain instructions for the execution of floors in contact with the ground that should be considered in the design phase.

In the event that piping should pass through the raised floor, the criteria indicated in section 5.4.5 of the DB-HS, regarding the execution of elements of connection to the buried networks, shall be taken into account.

When a waterproofing sheet must be placed on the lean concrete, the surface of this concrete must be flat. It should be considered that the waterproofing must support the weight of the screed and the loads of use under the Cáviti® columns.

5.4. Safety in use

The criteria related to the resistance and safety of use in the raised floor executed with the Cáviti® formwork are indicated in section 5.1.

Safety during product placement is set out in section 6.2.6.

Regarding the risk of falls due to the presence of unevenness, no special criteria are considered that differ from the general cases, included in the DB-SU of the CTE.

This requirement does not apply to the Cáviti® permanent formwork, since this element is not available to the users of the building and its bearing capacity is only relevant in the concreting process.

5.5. Protection against noise

The contribution to airborne noise insulation or impact noise insulation of horizontal partitions in which a Cáviti® screed is used has not been evaluated.

It is always recommended to separate the screed from the structure by means of perimeter ring beams and sheets of expanded polystyrene, but especially in those applications where acoustic insulation is required.

5.6. Energy economy and heat retention

No calculations of the contribution to the thermal insulation of raised floors have been made when they are part of the building's thermal envelope. To perform the calculation in each particular case, the following points can be considered:

- The contribution of the Cáviti® permanent formwork to the thermal insulation is negligible as it is not very thick.
- The thermal conductivity values of the concrete can be taken from table 3.4.1 of the *Construction elements catalogue of the CTE*, according to its density.
- It should be analysed, taking into account the dimensions of the screed, how the lower air chamber should be considered in the calculation.

The calculation of the thermal resistance of the raised floor may be carried out as indicated in the supporting document DA DB-HE, *Calculation of characteristic parameters of the envelope*. It should be taken into account that if the air chamber is not ventilated or slightly ventilated, the thermal resistance of the air is significantly higher than that of the concrete. In these cases, the possible thermal bridge effect that the resulting columns of the raised floor may have should be taken into account.

In order to check the risk of condensation, the permanent polypropylene formwork can play an important role as a vapour barrier. The joints between the Cáviti® parts cannot be considered completely watertight, but the following aspects must be taken into account:

- Water vapour may pass through the joints between the parts.
- The air contained in the lower part of the system should be considered a sealed or ventilated air chamber depending on the construction solution and in accordance with point 6 of Appendix E of the DB-HE.

5.7. Other design criteria

5.7.1. Durability

The durability of the concrete and the mesh used in the Cáviti® raised floors must meet the requirements specified in the Structural Code, especially as indicated in Chapter 29.

There are no specific requirements regarding the durability of Cáviti® parts, since its main function ends once the concrete has set.

5.7.2. Dimensional aspects of the system

Projects in which the Cáviti® system is used must take into account a series of geometric criteria that may affect the installation of the system:

Flatness of the support

The flatness of the support is one of the most relevant factors in the installation of the Cáviti® system, because the modules must fit together correctly. If the support is not flat enough, problems may occur during the pouring of the concrete, resulting in loss of material at the points where the fit between parts is not good.

When the system is installed on the ground, and in order to avoid the parts resting directly on it, a layer of lean concrete of at least 5 cm thick must be laid. It is recommended to use a concrete type HM-20/B/12-20/X0, although another type can be specified in the project. It is not considered necessary to use meshing reinforcement. This layer of lean concrete should be level, with a maximum level difference of about 10 mm per metre.

Consideration of the perimeters

The perimeters can be reinforced concrete walls, loadbearing brick walls, partition walls, columns (rectangular, square and circular), foundation footing, etc. The parts will reach the perimeters by means of an entire part, a cut part or a perimeter ring beam, depending on the structural criteria of the works (see section 6.1.3).

Modulation

It should be considered that the placement of the Cáviti® parts should always start with an entire part on at least two sides of the surface to be covered. In general, the rest of the sides should be resolved with the different meeting systems with the perimeters considered in this DAU.

Furthermore, when there is equipment, be it sanitation networks or electrical installations, it should be taken into account to reconsider them so that they do not coincide with the structural columns of the Cáviti® system, formed by the connection of four parts.

The technical department of Forjados Sanitarios Cáviti SLU can carry out a study of the placement of the parts, so that the designer can correct the passage of said equipment and avoid intersections. In case the interference between the equipment and the columns of the parts cannot be avoided, the technical department will promptly analyse the solution to be adopted.

Final height of the raised floor

In order to design the Cáviti® structure with the most appropriate solution, the height of the final floor must be known. With this data, the most suitable Cáviti® part and the thickness of the compression layer will be chosen, also taking into account that the expected mechanical stresses must be satisfied.

As indicated in section 1.3 of this DAU, the maximum height to which the screed can be raised is 70 cm, not counting the compression layer. In any case, in cases where there is an important height to be saved, the screed may be raised by placing successive screeds with the C-5 or C-10 parts and a 10 cm compression layer (see figure 6.1).

These raised floors can also be executed with larger parts, from C-15 to C-70, justifying their use correctly in each particular case. The thickness of the intermediate compression layer must guarantee the stability of the upper screed, taking into account its weight and the actions provided therein. The installation must ensure that the arrangement of the columns of the different screeds match (see figure 6.2).

Between layers, you must wait until the concrete has completely set. Once the concrete has set, any of the other heights of Cáviti® parts can be placed. In any case, but especially in these raised floors, the total weight of the system and the resistance of the support must be taken into account, as indicated in section 5.1.1.

5.7.3. Construction details

The construction details given in section 6.3 must be considered in design phase.

6. Installation, maintenance and repair criteria

6.1. Installation criteria

Proper installation of the Cáviti® parts is essential for the system to satisfactorily serve its purpose.

6.1.1 Prior conditions

Prior to the installation of the product, it must be verified that in the layout plans of the Cáviti® system, the equipment that can cross the screed (electrical and sanitation), as well as the vertical elements present in the work, have been considered. It must be verified that all the necessary details for the correct installation of the system have been included.

There is no special requirement regarding weather conditions during installation. The possible range of ambient temperatures does not affect Cáviti® parts or their use on site. The system can be installed as long as the weather conditions are considered fit to work.

Before starting the placement of the Cáviti® parts, check that the flatness of the support surface is adequate for the installation of the system (see section 5.7.2).

6.1.2 Placement of the Cáviti® parts

Parts must be manually placed by properly trained fitters. Project plans should be followed to maintain the intended layout.

The placement of the first part must respect the orientation indicated by the arrows located on the dome of the module, which indicate which side should be used to fit the next parts to be placed. The position of the part indicated in the project must also be respected, that is, if it is placed in a longitudinal or transverse direction. The following parts are placed following the position marked by the first part.

In connections with vertical elements, such as columns, walls, etc. the parts will be cut with a radial saw or with a special jigsaw for plastic, so that they adapt to the geometry of the element. In all the connections between the Cáviti® parts and the existing vertical elements in the work (walls, columns, protruding pits, catch basins, etc.), an expanded polystyrene plate of 3 cm to 5 cm thick and of a height equal to the screed must be placed (height of the part + height of the compression layer), which will act as a concreting joint. This plate can be fixed to the vertical element by small amounts of silicone.

6.1.3 Perimeter solutions and joints with columns

6.1.3.1 Free perimeters

In the event that there are no perimeter walls or any other limiting element, perimeter covers must be placed to prevent the loss of concrete during the concreting process. The dimensions of the perimeter caps must be adapted to the height of the planned screed. These

perimeter profiles have a perforated mark about 8 cm from one of its sides, along which the profile should be folded. The 8 cm part must be placed on the floor, under the legs of the Cáviti® parts. The remaining part, of greater length, must have the expected height of the screed and is attached to the Cáviti® parts by means of a wire that crosses both elements. The hole to pass the wire is made with a sharp object or a drill and at least one wire must be fixed in each part. Alternatively, this fixation can also be done with plastic flanges. It is recommended that the maximum distance between two adjacent fixing points be 50 cm, in order to prevent concrete from escaping between the Cáviti® part and the perimeter cover (see Figure 6.3).

6.1.3.2 Perimeters where the layout starts

When there are vertical elements from which the layout is started, the Cáviti® parts can be packed against them without the need to be cut.

In this case, the placement of the perimeter profile will not be necessary, but expanded polystyrene of a minimum thickness of 3 cm must be placed between the vertical element and the Cáviti® parts, to form a concreting joint (see figure 6.4).

6.1.3.3 Rest of perimeters

From higher to lower load, perimeters in which a whole part does not fit perfectly can be solved in the following three ways:

- Always ending with an entire part and forming a perimeter ring beam until the encounter with the corresponding vertical element, as indicated in the right part of figure 6.5. The increase in weight caused by the concrete of this ring beam must be taken into account.

This is the criterion to follow whenever the perimeter of the work does not coincide with the modulation of the Cáviti® parts or when said perimeter does not have a basically rectangular shape (circular, rhomboid plans, etc.).

- Alternatively, if the dimensions of the ring beam cause the expected loads to be exceeded, the dimensions of the ring beam may be reduced by cutting the Cáviti® parts and placing a perimeter cover similar to that described in the previous section.

In this case it is necessary to place a wall of perforated brick under the cut Cáviti® parts, in order to prevent them from overturning during concreting. These bricks cannot be considered to confer stability or support to the compression layer and therefore a ring beam with a minimum thickness of 20 cm should be executed (see the left part of figure 6.5).

- For imposed loads of use not exceeding 850 kg/m², and provided that in the execution phase the cut part is stable to overturning, the screed may be carried

out in cantilever, without the execution of a perimeter ring beam (see figure 6.6).

This solution must be duly justified in each particular case. Not only the distributed loads should be taken into account, but also the point loads that may be applied at the cantilevered ends of the screed, as well as its shear resistance.

The perimeter ring beam can be reinforced, if the conditions of the work require it or if it has been defined in design.

6.1.3.4 Encounters with columns

Encounters with concrete columns

In general, concrete columns do not have a shape that make special considerations necessary for the encounters of the Cáviti® system with them. Thus, the same criteria as those indicated in the previous sections will be followed to resolve these encounters. Figures 6.4, 6.5 and 6.6 show possible solutions of these encounters with concrete columns.

Encounters with metal columns

In this case, the Cáviti® system is placed up to the metal column support plate. Whether it is finished with an entire part or with a cut part, the general criteria described above must be followed. The remaining space until reaching the column can be filled entirely with concrete, or with a mixture of concrete and gravel in equal parts. In both cases a concrete type HA-25 N/mm² must be used. In any solution, it is recommended to separate the concreting from the column by means of a 3 cm to 5 cm expanded polystyrene concreting joint, although the project management may opt for other solutions (see figures 6.6 and 6.7).

6.1.4 Other singular points

6.1.4.1 Structural joints

In the structural joints the same solution will be followed as indicated in perimeter ring beams. If the layout allows starting from the structural joint in opposite directions, the parts will simply be placed against the material of the expansion joint. If, on the other hand, it is necessary to cut the Cáviti® parts in contact with the joint, a perimeter ring beam will be executed flush with the structural joint (see figures 6.8a and 6.8b).

The material to be used in the joint will be the one specified in the project.

In any case, the raised floor made with the Cáviti® system must respect the structural joints present in the support, if any, extending said joints to the Cáviti® screed following the construction solutions proposed in this section.

6.1.4.2 Passing equipment through the screed

Due to the wide variety of possible situations, the passing of equipment should be studied for each particular case. As a general criterion, the solutions to be executed must guarantee the stability and tightness

of the formwork during concreting, as well as the stability of the screed once the concrete has set. The passage of equipment through the Cáviti® modules must be sealed with polyurethane foam or expanded polystyrene before concreting (see figure 6.9).

In the particular case of the catch basins, it is recommended to make some perforated brick side partitions that avoid having to cut the Cáviti® parts, and thus facilitate the installation and concreting process.

6.1.5 Concreting

6.1.5.1 Prior operations

Once all the parts have been placed and all the singular points have been solved, the electro-welded mesh is placed. It is convenient to place this mesh just after finishing the placement of the parts, in order to avoid possible blows, high traffic over the parts or any incident that can cause damage to the formwork and thus avoid unnecessary repositioning.

When polypropylene fibres are used as the sole reinforcement of the screed, the necessary auxiliary elements must be used temporarily to ensure the safety of staff during concreting (for example, planks). This precaution is not necessary in Cáviti® type C-5 or C-10 parts because the part itself is capable of ensuring safety and stability to the staff carrying out the execution of the screed.

Before concreting, the replacement of Cáviti® modules in the case of breakage is quick and easy. If the break is not very large, it is enough to cover the affected area. If the damage is unrepairable, the affected parts must be completely replaced.

The electro-welded mesh will be placed over the entire surface of the screed, including the upper part of the perimeter ring beams. The function of this reinforcement is to avoid the surface cracking of the screed caused by shrinkage of the concrete. For this reason, it is recommended that the reinforcement be placed near the final concreted surface, about 30 mm maximum. In any case, the minimum covers indicated in section 44.2.1 of the Structural Code must be respected. Conventional reinforcement separators must be placed in order to ensure said cover.

The different meshes will overlap each other, with a minimum length of overlap between meshes of 20 cm.

6.1.5.2 Pouring the concrete

Concrete can be poured by pump or bucket. In both cases the appropriate measures will be taken for the correct installation. Because the fit between parts is not completely tight, it is not advisable to use fluidised concrete, as it could cause the loss of material through the joints.

The flow and pouring height should be controlled so that the joints between the parts do not open when pouring concrete. The maximum recommended height for concrete pouring is 1 m. First the concrete will be poured

on the columns, in order to stabilise the Cáviti® parts, and then on the rest of the surface, until it reaches the height of the pavement base.

Two operators will be needed to manipulate the concrete element (pump or bucket), and the rest will distribute the concrete throughout the surface by means of rakes or grout floats. One of them must quickly introduce the column vibrator to avoid pockets inside the structure and facilitate the setting and hardening process. It should be taken into account that there is little concrete on the columns, and therefore prolonged vibration is not necessary. It is important that the vibration is performed with vibrators of columns, and not of floor screeds, as well as that the vibration has the right duration. Excessive vibration can cause the joints to open between parts, letting out the poured concrete and having to start the whole process again.

In periods of high temperatures (mainly in summer) the concreted surface must be moistened to ensure a good setting of the concrete.

In the event that the concrete surface must be finished with a smoothed finish, once the concrete begins to harden, it will be possible to sprinkle quartz dust and then pass the helicopter, treating the surface like a traditional screed.

The prudential time to wait to load the screed, either with struts to lift subsequent floors or other structures, is at least 15 days from the concreting. Setting accelerators can be used in situations where the structure must be loaded before this period. The struts must be placed on sleepers in order to distribute loads.

6.1.6 Requirements to be met by fitters

The technical department of Forjados Sanitarios Cáviti SLU demands the following requirements to the operators for the placement of the system:

- Fitters must have previously seen the placement system and the order that must be followed for a good fit between parts.
- They must know how the cut parts are placed to avoid material losses through the joints.
- They must know how to handle the product and how to use the machinery for cutting the parts.
- They must have adequate health and safety knowledge. System fitters must wear personal protective elements (PPE) at all times for the planned work: safety boots, gloves, helmet, goggles (when cutting Cáviti® modules and mesh reinforcements, and in concreting operations) and concreting boots. They must respect the provisions for collective protection at work.

In addition, special attention should be paid when walking on the formwork before and during concreting

since, in most of the Cáviti® parts (from C-15 onwards), the gaps formed by the columns have a significant size and they can cause the operator to fall. The placement of the anti-crack reinforcement can improve the security against these falls, since it prevents the foot from fitting into the hole but, in any case, the operators must be careful when working on the formwork. It should also be borne in mind that reinforcement separators used in layers greater than 5 cm (see section 2.4) can hinder the passage of operators during the concreting process.

It should be checked that the parts used are in good condition and do not present any defects that may compromise the stability of the operators when walking on them.

Tests have been carried out to evaluate the resistance of the parts to the passage of the operators, the results of which are shown in section 9.4.2.

6.2. Criteria for maintenance and repair

Once the screed has been concreted, the maintenance requirements of any concrete element executed on site will be followed.

In general, if a repair due to collapse or perforation of the raised floor is necessary, the affected area should be cleaned, the cause of failure must be resolved and a screed equal to the existing one should be made. In each case, the actions to be carried out must be assessed.

6.3. Construction details

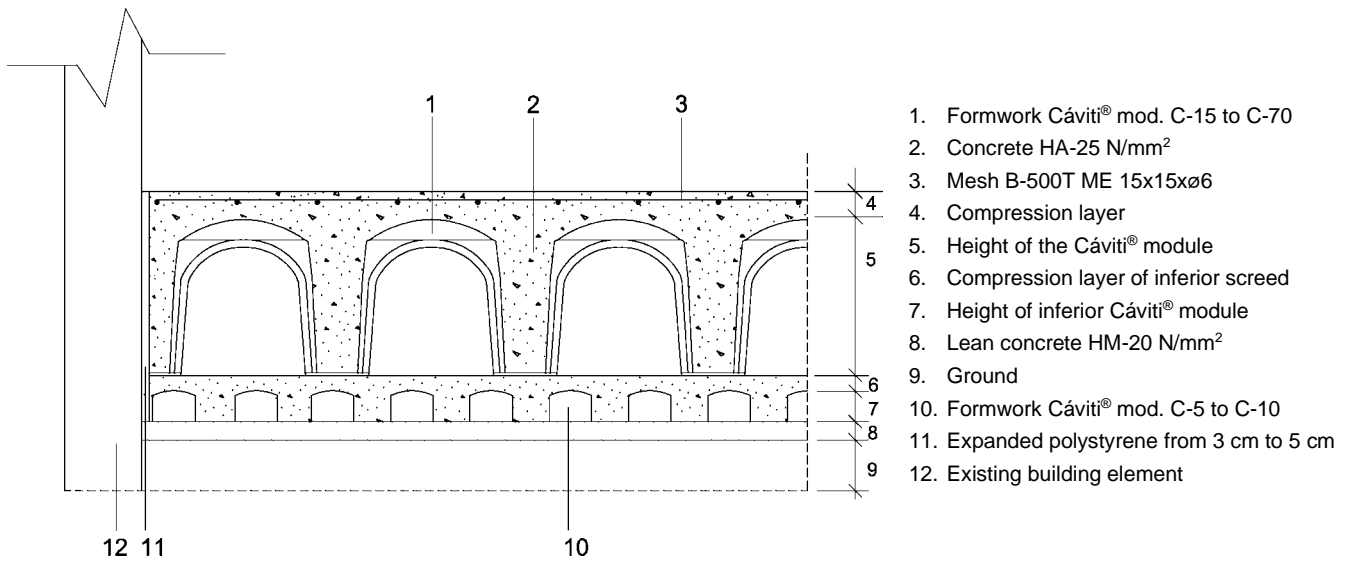

Figure 6.1: Execution of the screeds with special parts C-5 and C-10.

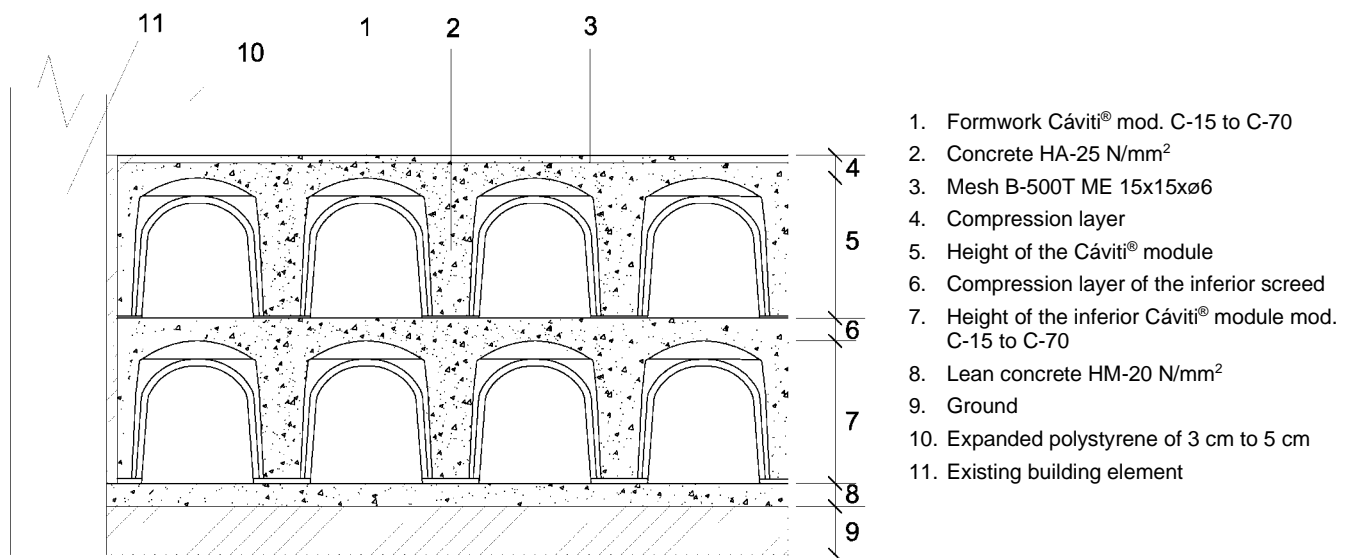
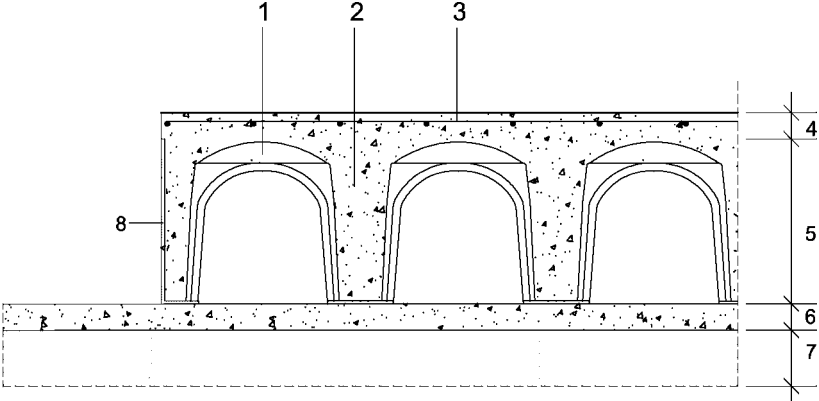
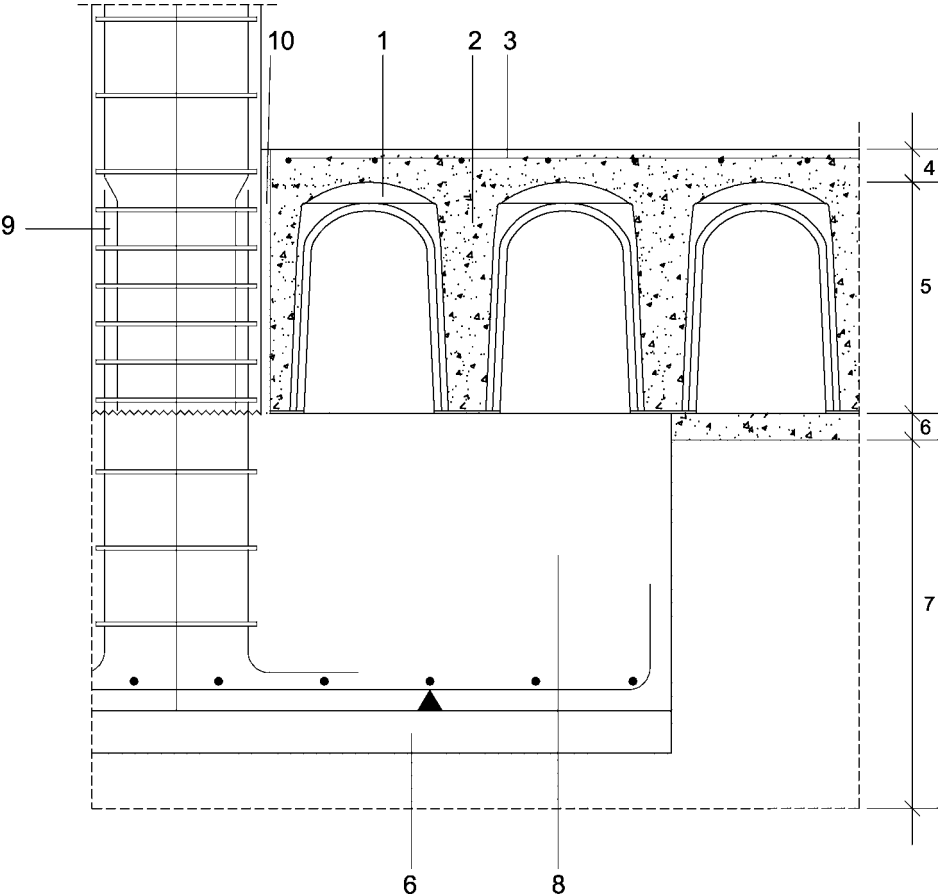

Figure 6.2: Execution of the screeds with the parts C-15 to C-70.



- 1. Formwork Cáviti® mod. C-15 to C-70
- 2. Concrete HA-25 N/mm²
- 3. Mesh B-500T ME 15x15ø6
- 4. Compression layer
- 5. Height of Cáviti® module
- 6. Lean concrete HM-20 N/mm²
- 7. Ground
- 8. Perimetral cover

Figure 6.3: Free perimeters.



- 1. Formwork Cáviti® mod. C-15 to C-70
- 2. Concrete HA-25 N/mm²
- 3. Mesh B-500T ME 15x15xø6
- 4. Compression layer
- 5. Height of Cáviti® module
- 6. Lean concrete HM-20 N/mm²
- 7. Ground
- 8. Footing or foundation slab
- 9. Existing column
- 10. Expanded polystyrene from 3 cm to 5 cm

Figure 6.4: Perimeters where the layout is initiated.

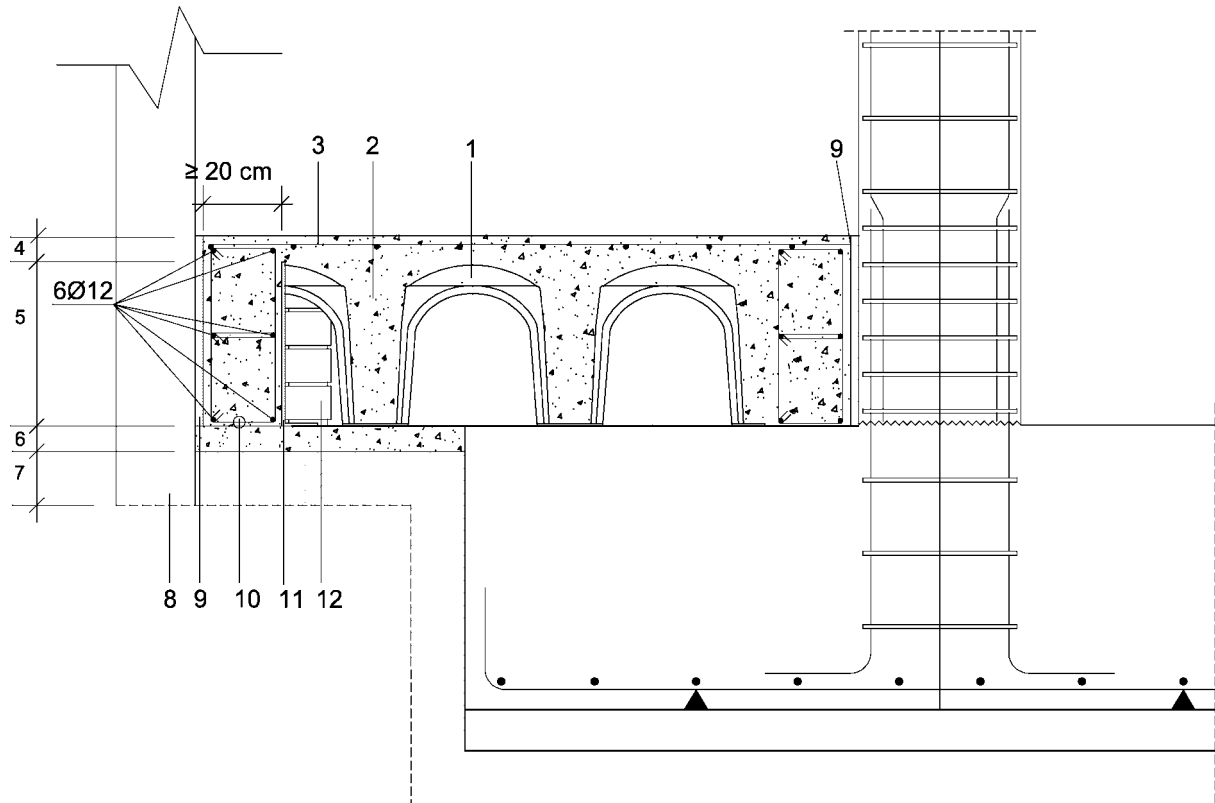

- | | | |
|---------------------------------------|--|---|
| 1. Formwork Cáviti® mod. C-15 to C-70 | 5. Height of the Cáviti® module | 9. Expanded polystyrene from 3 cm to 5 cm |
| 2. Concrete HA-25 N/mm ² | 6. Lean concrete HM-20 N/mm ² | 10. Assembly reinforcement |
| 3. Mesh B-500T ME 15x15xø6 | 7. Ground | 11. Perimeter cover |
| 4. Compression layer | 8. Existing building element | 12. Brick wall to support the cut Cáviti® part. |

Figure 6.5: Perimeter solution with perimeter ring beam.

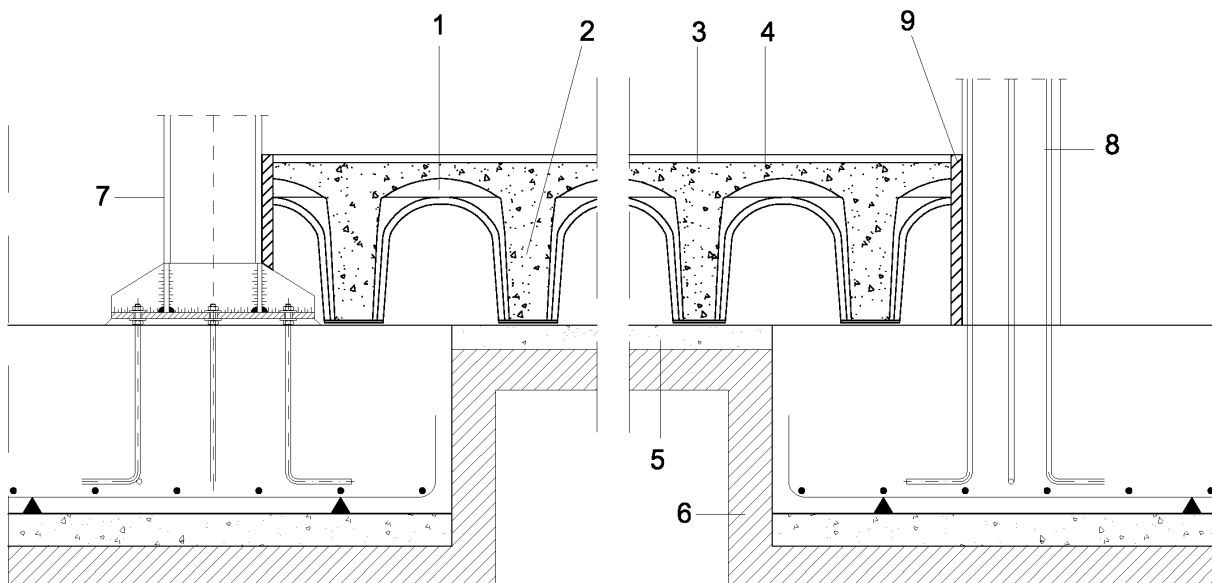

- | | | |
|---------------------------------------|--|---|
| 1. Formwork Cáviti® mod. C-15 to C-70 | 4. Compression layer | 7. Metal column |
| 2. Concrete HA-25 N/mm ² | 5. Lean concrete HM-20 N/mm ² | 8. Column / concrete element |
| 3. Mesh B-500T ME 15x15xø6 | 6. Ground | 9. Expanded polystyrene from 3 cm to 5 cm |

Figure 6.6: Cantilever encounters in the screed (without ring beam).

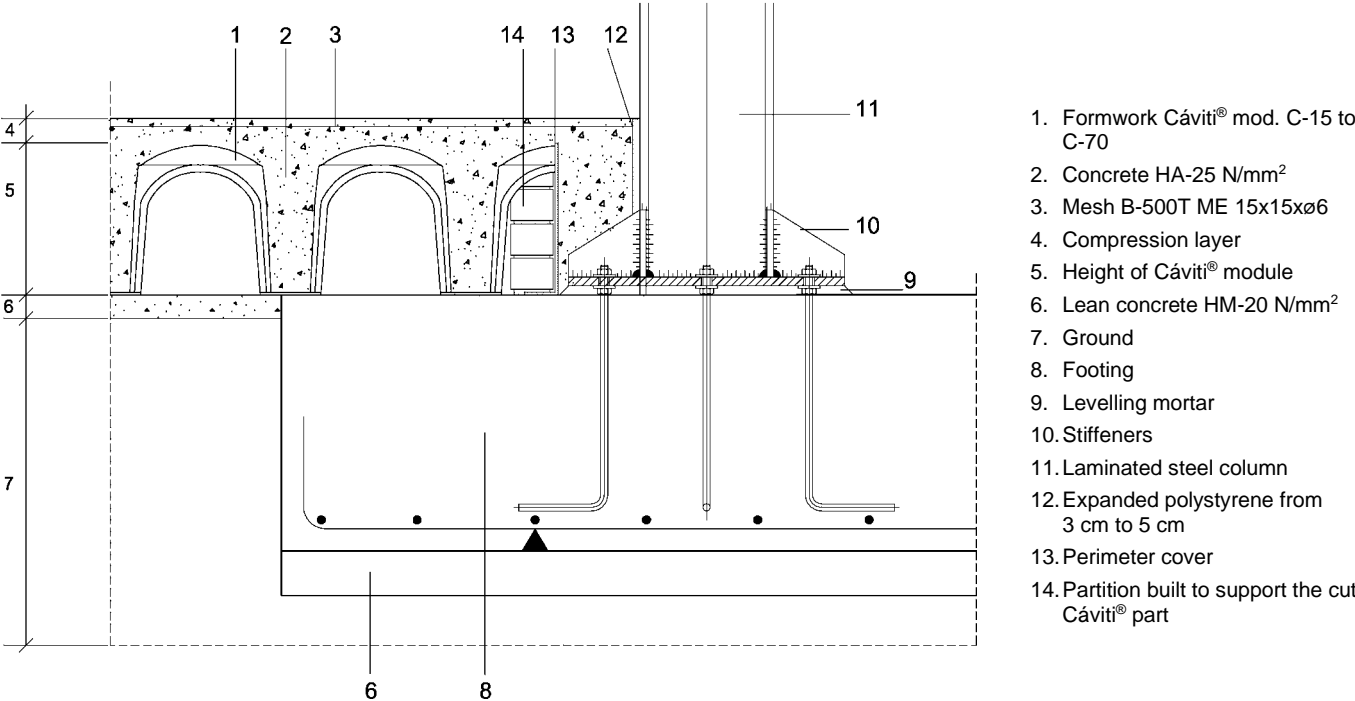

Figure 6.7: Encounter with a metal column. Separate module.

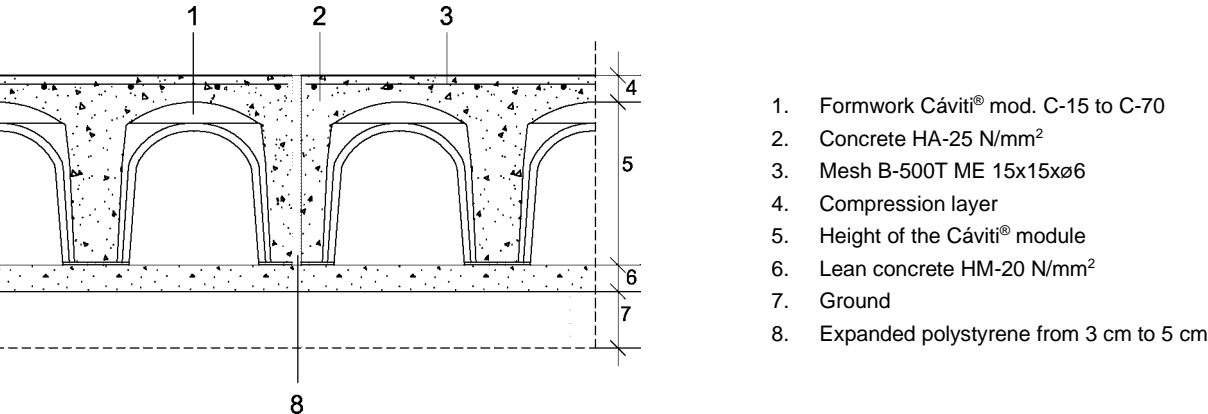

Figure 6.8a: Structural joints (layout starts at the joint).

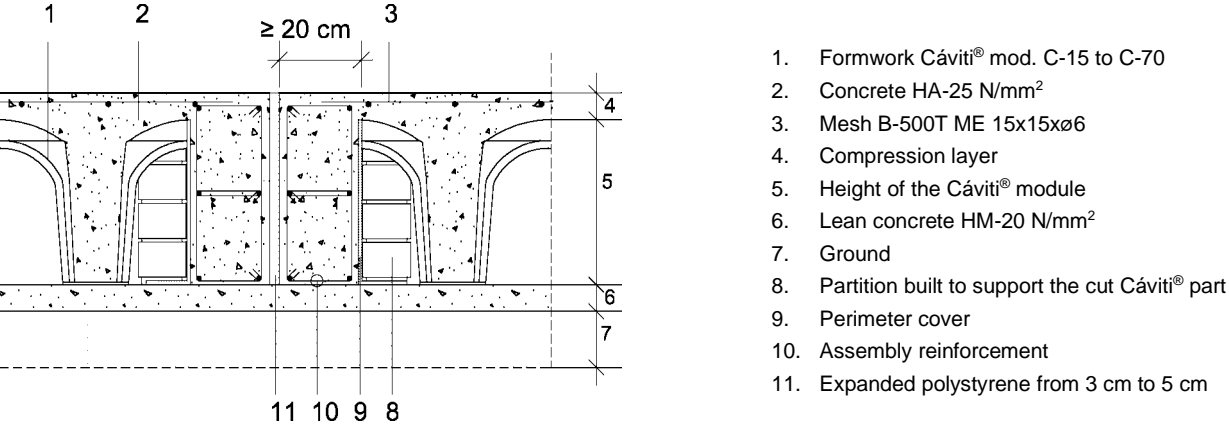
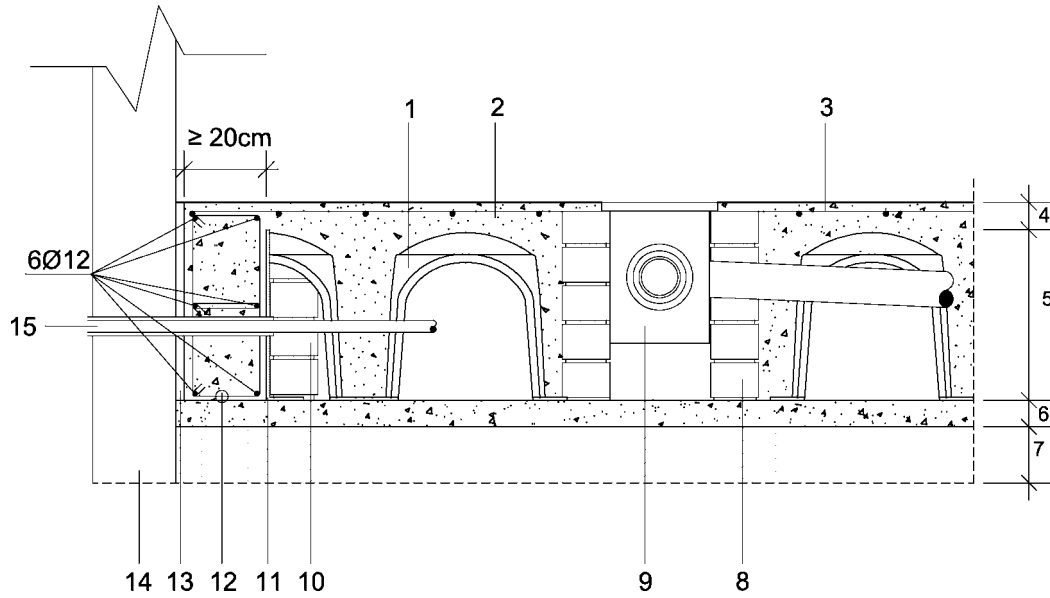

Figure 6.8b: Structural joints with perimeter ring beam.



- | | |
|--|---|
| <ol style="list-style-type: none"> 1. Formwork Cáviti® mod. C-15 to C-70 2. Concrete HA-25 N/mm² 3. Mesh B-500T ME 15x15xø6 4. Compression layer 5. Height of the Cáviti® module 6. Lean concrete HM-20 N/mm² 7. Ground | <ol style="list-style-type: none"> 8. Partition built for the installation of the catch basin 9. PVC catch basin 10. Partition built to support the cut Cáviti® part 11. Perimeter cover 12. Assembly reinforcement 13. Expanded polystyrene from 3 cm to 5 cm 14. Existing building element 15. Installation through a perimeter ring beam |
|--|---|

Figure 6.9: Passage of piping and equipment.

7. References of use

This raised floor construction system has been used since 1998. Forjados Sanitarios Cáviti SLU provides as references of use the following list of works, which indicates, in this order, the work, the location, the types of parts used and the uses of the system:

- V.v. Balcón de San Lázaro, Zaragoza | C-5, 3,450 m² | Ventilated screed.
- V.v. Mina del Morro, Bilbao | C-5, 1.100 m² | Ventilated screed for car park.
- Évora (Portugal) | C-15, 2.400 m² | Ventilated screed for industrial warehouse.
- Ctro. Investigación Migres, Tarifa (Cádiz) | C-15, 1.100 m² | Suspended flooring.
- AVE tunnel, section Vigo-Urzaiz (Pontevedra) | C-15, 11.500 m² | Permanent formwork, water channel.
- CEIP La Atunara, La Línea de la Concepción (Cádiz) | C-20 and C-25, 350 m² | Suspended flooring.
- Ctro. Tecnológico del Automóvil de Galicia, Porriño (Pontevedra) | C-25, 2.750 m² | Suspended flooring, industrial warehouse.
- V.v. Carrer Urani, Barcelona | C-20 and C-25, 2.400 m² | Screed and suspended flooring.
- Ministry of Culture, Madrid | C-25, 256 m² | Screed on existing floor screed.
- Cold room Molino Cañuelas, Buenos Aires (Argentina) | C-30, 1.850 m² | Suspended flooring on slab.
- Hotel Conde Luna, León | C-35, 700 m² | Screed on rooftop.
- Zarzuela Palace, Madrid | C-30, 160 m² | Screed on existing floor screed.
- Bank of Spain, Madrid | C-30, 120 m² | Screed on existing floor screed.
- Tarragona port police building | C-40, 750 m² | Suspended flooring.
- Bodegas Mauro, Villaester (Valladolid) | C-55, C-60 and C-65, 815 m² | Suspended flooring, industrial warehouse.
- BBVA building, Tres Cantos (Madrid) | C-30, C-35 and C-70, 1.200 m² | Screed on existing floor screed.
- Tower El Dorado Airport, Bogotá (Colombia) | C-30 to C-40, 6.400 m² | Suspended floorings.
- Farm school, Duruelo (Segovia) | C-50 to C-70, 2.600 m² | Suspended flooring.
- V.v. Osorio, Cádiz | C-30, C-35, C-45 and C-70, 2.100 m² | Suspended flooring on slab.

8. Site visits

A sampling of works was carried out in which the Cáviti® system was used for the execution of raised floors. The selected works were inspected by ITeC technicians and the resulting information is collected in the DAU site visits report.

The aspects listed below are the result of the observations made in the site visits and reflect relevant aspects to highlight for a correct execution of the system:

- Ground resistance is a basic parameter when the system rests on it. The project must consider whether it is necessary to have a foundation slab under the Cáviti® screed to avoid system failure due to ground punching shear. In any case, the lean concrete layer should not be considered as a load distribution element, since it is not reinforced.
- There should be layout plans that define the passage of equipment through the screed and under the screed. In any case, once the equipment that must pass under the Cáviti® screed is made, it must be verified that the arrangement of the parts does not conflict with this equipment.
- It is always recommended to use the perimeter cover in free perimeters (without perimeter wall) and in encounters between two Cáviti® parts of different heights. It is not recommended to execute other types of solution, such as having a geotextile to join different heights.
- The perimeter cover has a rebate that allows a strip about 8 cm to be arranged under the Cáviti® parts, for greater safety during concreting. This is the correct arrangement. Other arrangements of the perimeter cover may favour formwork failure during concreting.
- In general, it is recommended to use the perimeter solutions indicated in this DAU. Other solutions not included in this document can be executed, if necessary, as long as it is guaranteed that the cut Cáviti® modules are well supported, that no gap is left where the concrete can escape when pouring it and that there is no part of the final screed that bends or is a cantilever.

These aspects, together with other minor indications observed in the work, have been introduced in the text of this DAU, mainly in sections 5 and 6.

9. Assessments of tests and calculations

9.1. Introduction

The experimental phase of this DAU has consisted of performing the following tests and calculations:

1. Characterisation tests of the Cáviti® parts.
2. Tests and calculations of the final raised floor executed with the Cáviti® system.
3. Tests for evaluation of the system in the execution process.

These tests have been carried out by Applus + LGAI, in accordance with the guidelines specified by the ITeC in the Particular Evaluation Procedure of the DAU 14/086. This document has been prepared by the ITeC considering the basic requirements of the works and the current Spanish regulations.

The tests have been performed with samples taken by an ITeC technician. The test specimens were performed by the laboratory itself, also under the supervision of an ITeC technician.

The test and calculation report, as well as the sampling reports, can be found in the Technical Dossier of the DAU 14/086. Below is a summary of their results.

9.2. Characterisation tests of the system elements

9.2.1 Characterisation of Cáviti® parts

Tests have been carried out to identify the Cáviti® parts that have been used in the system tests. The results obtained are consistent with the values declared by the manufacturer, which are included in table 2.1 of section 2.1.

Characterisation of the polypropylene of the parts

The results of the tests carried out with the recycled polypropylene that forms the Cáviti® parts are summarised in table 9.1. These tests have been carried out with specimens formed from the raw material taken at the factory and whole parts of the type C-15.

9.2.2 Characterisation of the concrete

The concrete used in the specimens has been prepared in the factory and taken to the laboratory in tanks on the day of its preparation. Concrete identification tests of each of the two tanks that have been necessary for the preparation of the specimens have been carried out. In both cases, the concrete in question has been of type

HA-25/B/20/IIa¹. The results of the tests performed are presented in table 9.2.

Characteristic	Test regulation	Test result
Mass flow rate (MFR)	UNE-EN ISO 1133-1	12,6 g/10 min
Impact resistance (Izod)	UNE-EN ISO 180	Average value: 25,2 kJ/m ²
Impact resistance (Charpy)	UNE-EN ISO 179-1	Average value: 17,3 kJ/m ²
Ash content	UNE-EN ISO 3451-1	Average value: 14,3 %

Table 9.1: Results of identification of the polypropylene of Cáviti® parts.

Characteristic	Test regulation	Test result
Consistence (Concrete slump test)	UNE-EN 12350-2	5 cm (in both cases)
Dry density	UNE-EN 12390-7	Mix 1: 2,21 g/cm ³ Mix 2: 2,18 g/cm ³
Resistance to compression (7 days)	UNE-EN 12390-3	Mix 1: 30,3 MPa Mix 2: 29,1 MPa
Resistance to compression (28 days)		Mix 1: 34,9 MPa Mix 2: 34,7 MPa

Table 9.2: Results of identification of the concrete used in the tests.

The results obtained show that the resistance is significantly higher than the minimum required by the manufacturer. This effect has been taken into account in the subsequent treatment of the compression resistance results of the screed (section 9.3.1).

9.2.3 Anti-crack reinforcement

The mesh used to prevent shrinkage cracking of the compression layer was the type 20 x 20 Ø6, one of those considered the most unfavourable of the set of meshes proposed by the DAU holder. The results of the identification of this mesh comply with the UNE 36092 standard.

¹ Typification of the concrete used for the test, according to EHE-08 (HA25/B/20/XC2, according to Structural Code).

9.3. Tests and calculations of fitness of use of the system

9.3.1. Mechanical resistance and stability and safety of use

Point load and distributed load resistance tests of representative specimens of the final concreting system have been carried out. The typology of the specimens is summarised in table 9.3.

The application of the load in the point load test was carried out using a 50 mm x 50 mm load applicator, as indicated in table 3.1 of the DB-SE-AE. In the case of distributed load, the applicator occupied the entire concreted surface of the specimen. In both cases, the test was prolonged until cracks 2 mm thick appeared. The results obtained in these tests, once different minoration coefficients have been applied, are summarized in table 5.1.

In general, the results obtained have been much higher than the limits of table 3.1 of the DB-SE-AE of the CTE, which indicate the characteristic value of the imposed loads. Likewise, the resistance to point loads of the system is sufficient for use in areas of traffic and parking of light vehicles (category of use E).

9.3.2. Safety in case of fire

9.3.2.1. Reaction to fire

In accordance with Commission Decision 96/603/EC and its subsequent modifications, concrete can be classified as a class A1 reaction to fire without the need for testing.

Tests provided by the manufacturer show that Cáviti® modules have a class E reaction to fire, in accordance with the UNE-EN 13501-1 standard.

9.3.2.2. Resistance to fire

No tests have been carried out on the contribution to the resistance to fire made by the Cáviti® screed. The project criteria indicated in section 5.2.2 must be followed.

9.3.3. Hygiene, health and the environment

9.3.3.1. Watertightness

Tests have been carried out to evaluate the watertightness of the Cáviti® modules as permanent formwork under a raised concrete floor. The results of these tests show that the joints between Cáviti® parts are not watertight enough to be considered waterproof. It is estimated that in a situation where there may be permanently water on the support of the system, it could penetrate by capillarity.

9.3.4. Protection against noise

No test of the contribution to the acoustic insulation of the raised floor has been carried out, for cases in which it is part of a horizontal partition.

9.3.5. Energy economy and heat retention

No tests have been performed to determine the thermal insulation of the raised floor. It is considered that the hygrothermal values necessary to perform thermal insulation calculations and the possibility of condensation will be obtained from different references, as indicated in section 5.6.

Cáviti® part	Compression layer (cm)	Anti-crack mesh	Specimen format	Concreted surface
C-5	5	20 x 20 Ø6	4 pieces (2 x 2)	2 x 2 parts
	8			
	10			
C-40	5	20 x 20 Ø6	9 pieces (3 x 3)	2 x 2 parts (centred in the 4 columns of a part)
	8			
	10			
C-70	5	20 x 20 Ø6	9 pieces (3 x 3)	2 x 2 parts (centred in the 4 columns of a part)
	8			
	10			

Table 9.3: Type of specimens tested under point and distributed loads.

9.4. Assessment tests of the system in the assembly process

Tests have been carried out to evaluate the ability of the Cáviti® modules to withstand the loads to which they are subjected during the execution of the raised floor. Two aspects have been proven:

- The formwork's capacity to withstand the stress of concreting.
- The formwork's capacity to withstand the stress caused by operators walking across it (compression resistance of the formwork).

9.4.1. Resistance to concreting stress

During the preparation of the specimens of the system tests, special attention has been given to the concreting and vibrating process, in order to verify how they affect the tightness of the formwork.

It has been observed that in general, if the concreting is carried out from a low height and at a moderate speed, the formwork can easily withstand the thrust of the concrete. In some cases, there has been a slight opening of the joints between parts or small leaks of concrete at the base of the columns, which in no case are considered relevant for the correct setting of the raised floor and that may have been due to excessive vibration.

Tests have also been carried out pouring concrete from a height of approximately 1,5 m, exceeding the recommended maximum of 1 m, and at a high speed. These tests have been carried out on confined specimens of 4 x 4 modules, with parts C-40 and C-70. In these cases, it has been proven that the concrete can significantly open the joints between modules and even, in some cases, leak completely from the formwork and go to the ground.

In summary, these tests show that the concrete must be poured carefully and in a controlled manner, with adequate vibrating (column vibrator) and by properly trained and equipped staff.

9.4.2. Formwork resistance to compression

Compressive strength tests of non-concreted Cáviti® parts have been performed. The results of the tests show that the modules, fitted together, can easily withstand the loads corresponding to the passing of an operator. In the test it has been observed that C-40 parts can withstand 100 kg loads with a deformation of around 10 mm. The C-70 parts have obtained higher values, around 250 kg for 10 mm deformations.

It is concluded that these parts, if they are in good condition and without breaks, can withstand the passing of the operators who must work on them.

In any case, the instructions in section 6.1.6 regarding the safety of fitters must be followed.

10. Experts commission

This DAU has been submitted to the opinion of an Experts Commission, as indicated in the *Reglamento del DAU* (DAU Regulation) and in the Work Instruction for the elaboration of DAU.

The Experts Commission was constituted by representatives of different organizations and institutions, which have been chosen for their knowledge, independence and impartiality to give a technical opinion regarding the scope of this DAU.

The general list of experts that have made up the experts commissions of DAU is available on ITeC website itec.es.

Comments and observations raised by the DAU Commission members have been included in the text of the present DAU.

11. Reference documents

Mandatory Construction Regulation:

- Technical Building Code (CTE).
- Structural Code (Royal Decree 470/2021).

Product standards:

- UNE-EN 15345 Plastics. Recycled plastics. Characterisation of Polypropylene (PP) recyclates.

Other test, calculation and classification standards:

- UNE-EN ISO 178. Plastics. Determination of flexural properties.
- UNE-EN ISO 179-1. Plastics. Determination of Charpy impact properties. Part 1: Non-instrumented impact test.
- UNE-EN ISO 180/A1/A2. Plastics. Determination of Izod impact strength.
- UNE-EN ISO 527-1. Plastics. Determination of tensile properties. Part 1: General principles.
- UNE-EN ISO 527-2. Plastics. Determination of tensile properties. Part 2: Test conditions for moulding and extrusion plastics.
- UNE-EN ISO 1133-1. Plastics. Determination of the melt mass-flow rate (MFR) and melt volume-flow rate (MVR) of thermoplastics. Part 1: Standard method
- UNE-EN ISO 3451-1. Plastics. Determination of ash. Part 1: General methods.
- UNE-EN 12390-3. Testing hardened concrete. Part 3: Compressive strength of test specimens.
- UNE-EN 12350-2. Testing fresh concrete. Part 2: Slump-test.
- UNE-EN 13501-1. Fire classification of construction products and building elements. Part 1: Classification using data from reaction to fire tests.
- UNE-EN 15343. Recycled plastics. Plastics recycling traceability and assessment of conformity and recycled content.
- UNE 36068 /1M. Ribbed bars weldable Steel for the reinforcement of concrete.
- UNE 36099. Deformed steel wires for concrete reinforcing.
- UNE 36092. Steel welded fabric for structural use in concrete reinforcement. Steel welded fabric made out of steel wires B 500 T.

12. Assessment of fitness for use

Based on the following experimental technical evidence obtained during the preparation of the DAU 14/086 according to the criteria defined in the *Procedimiento Particular de Evaluación del DAU 14/086*, prepared by ITeC:

- tests and calculations results,
- information from the site visits,
- factory production control,
- instructions for system installation and execution,
- project and execution criteria,

and taking into account the methodology prescribed in the *Reglamento del DAU*, the authorization and the ITeC register for awarding DAU* and the indications in section 5.2 of article 5 of the CTE-*Código Técnico de la Edificación*, regarding the assessment of products

and innovative systems, it is considered that ITeC has the evidences to declare that the constructive system of permanent formworks formed by Cáviti parts manufactured in the Cáviti - Plásticos de Palencia plant in Venta de Baños and in the Cáviti - Envaplas plant in Almazora, and executed according to the instructions given in this DAU, is appropriate for its use in:

- formation of permanent formworks in construction of raised floors in general and substitution of traditional suspended floorings,

since it fulfils the relevant regulatory requirements on mechanical resistance and stability, safety in case of fire, hygiene and health, as well as durability and serviceability requirements.

As a result, and once this document has been submitted to the Experts Commission and their comments have been included in it, ITeC awards the DAU to the product manufactured by Forjados Sanitarios Cáviti SLU.

The DAU validity is subjected to the actions and monitoring conditions specified in chapter 13 and to the use conditions of chapter 14.

(*) ITeC is an authorized organism for awarding the DAU (BOE 94, 19 April 2002) for construction products (building and civil engineering) registered in the General Register of the CTE: <https://www.codigotecnico.org/RegistroCTE/OrganismosAutorizados.html>.

DAU 14/086
Documento
de adecuación al uso



ITeC Technical Director



13. DAU monitoring

The present DAU is subjected to the surveillance actions that ITeC carries out periodically, in accordance with the *Reglamento del DAU*. The purpose of this monitoring is to check that the characteristics of the product and the constructive system, as well as the execution and manufacturing conditions, are still valid for the envisaged intended uses.

If relevant changes affecting the DAU validity occur, these will result in a new DAU edition that will supersede the previous one (this new edition will take the same DAU code as the superseded one and a new letter edition).

When changes are of minor importance and they do not affect the DAU validity, these will be specified in a list of changes that will be incorporated as chapter 15 of the DAU; furthermore, these changes will be included as well in the DAU text.

The DAU user must always look up the DAU electronic version available in pdf format on ITeC website itec.es, in order to make certain of its possible revisions that may occur during its validity. This document is also available through the QR code included in the DAU stamp.

14. Use conditions of DAU

In granting the DAU, the ITeC is not responsible for:

- The presence or absence of any patent, intellectual property or similar existing rights subsisting in the product or any other product, nor rights that affect third parts or the fulfilment of obligations to any of this third parts.
- The right of the DAU holder to manufacture, supply, install or maintain the product.
- The actual works or individual batches in which the product is installed, used and maintained; including the nature, design, methods and workmanship of or related to the installation.

In addition, the DAU cannot be ever interpreted as a guarantee, commitment or responsibility of the ITeC relating to the commercial viability, patentability, registrability or innovation of the results derived from the preparation of the DAU. This is, then, the holder's responsibility to check the viability, patentability and registrability of the product.

The assessment of the DAU does not purport in any way to restate the regulatory requirements of the Health & Safety at Work or occupational risk prevention, relating to the manufacture, supply, installation, use and maintenance of this product. Therefore, the ITeC does not accept responsibility to any person or body for any loss or damage, including personal injury, which may occur in the event of breach of the relevant requirements within the mentioned legislative framework.

15. List of changes of the present edition

The electronic version of the DAU includes, if any, the updating, changes and corrections of the present edition D of the DAU 14/086, indicating the date of incorporation, according to the format of the following table. The changes shown in the table will also be integrated in the text of the DAU, which is available on the Institute's website, itec.es.

The DAU user must always consult the DAU electronic version in order to make certain of its possible revisions, which may occur during its validity.

Number	Page and chapter	Where it was said ...	It says ...
--------	------------------	-----------------------	-------------



**Institut de
Tecnologia de la Construcció
de Catalunya**

Wellington 19
ES08018 Barcelona
T +34 933 09 34 04
qualprod@itec.cat
itec.es

